



**Автоматическая установка компенсации реактивной мощности Socomes Cosys -  
руководство по эксплуатации. Юниджет**

Постоянная ссылка на страницу: <https://www.uni-jet.com/catalog/kompensatoryi-reaktivnoj-moshhnosti/avtomaticheskaya-ustanovka-socomes-cosys-pfc.html>



# *Automatic COSYS PFC system*

Operating instructions **EN**



WARRANTY CONDITIONS	3
GENERAL SAFETY AND USAGE	
INSTRUCTIONS	4
SYSTEM DESCRIPTION	5
General points	5
Function	5
Construction	5
General characteristics	5
PFC system schematic diagram	6
INSTALLATION	7
Recommendations relating to installation conditions	7
Connecting the input cables	7
Upstream protection and connection cross section	7
Technical characteristics	8
COMMISSIONING AND MAINTENANCE	12
Checking the equipment	12
Current transformer	12
Powering up	12
Setting the regulator parameters	12
Operating faults	12
Maintenance	13

The warranty conditions are set out in the sales contract; in all other cases, the following conditions shall apply.

The manufacturer guarantees its product against any manufacturing or operating faults caused by errors in design, choice of materials or manufacture, in accordance with the conditions set out below.

The manufacturer may - without prior notice – modify its product in order to bring it into line with the warranty conditions or replace defective parts.

The manufacturer's warranty shall not apply in the following cases:

- Faults caused by designs or parts used without consent, or supplied, by the buyer.
- Replacements or repairs resulting from normal wear and tear of parts and equipment
- Damage or injury caused by negligence on the user's part
- Insufficient maintenance or incorrect use of products.
- PFC system not adapted to the network.

The warranty's validity period is 12 months following installation of the equipment, and may not exceed 18 months from the supply date.

Parts replacements, repairs or modifications carried out by the manufacturer during the warranty period may under no circumstances be grounds for extending the

length of the warranty period.

In order to benefit from this warranty, buyers must expressly inform the manufacturer - within a maximum of 8 days, beyond which the warranty shall expire – of any faults in the design, materials or manufacture, giving precise evidence to support their claim.

Defective parts replaced free of charge by the manufacturer must be made available to the manufacturer, as they remain its sole property.

The warranty shall not apply if the buyer has carried out modifications or repairs to the manufacturer's products without its prior consent.

The manufacturer's liability is limited to the obligations described above (repairs or replacements); all other types of damage shall be excluded.

# GENERAL SAFETY AND USAGE INSTRUCTIONS



The conditions set out below are likely to cause operating faults and reduce the PFC system' service life:

- Current, voltage and frequency which are not to specification.
- The presence of harmonics.
- Operation or storage outside the temperature limits.
- The use of switches without current limiting resistors.
- Operation: where there are shocks or vibrations, excessive or rapid temperature variations, or in an explosive or corrosive environment.
- Installation at an altitude > 2,000 m or below sea level.

- a. This manual sets out the essential instructions relating to safety, connection and use of the automatic PFC system.
- b. This system must only be installed by specialist personnel with the necessary skills.
- c. The PFC system must be installed in a vertical position.
- d. The cable must be connected to earth before the connections are made.
- e. Do not expose the equipment to rain or splashes of water.
- f. Keep the enclosure clean using a dry cloth.
- g. We recommend that you keep this manual in a place which is accessible to all.
- h. The maintenance and checking operations described in the "Maintenance" paragraph on page 13 must be carried out at least once every 12 months. Failure to follow this instruction shall release Socomec from all liability with regard to the incorrect operation of the equipment and the consequences thereof.
- i. The maintenance operations must only be carried out by authorised personnel with the appropriate training.
- j. This system satisfies the European Community directives applicable to this product. This is indicated by the following marking:



- k. Compliance with standards CEI 61439-1/-2 and EN 61439-1/-2.

# SYSTEM DESCRIPTION

## General points

The equipment consists of one or several racks of capacitors installed in an enclosure. Each rack represents a reactive power expressed in kVAR.

The racks are divided into steps which are connected or disconnected automatically, according to the reactive power required.

## Function

The COSYS automatic PFC PFC system are designed to offset variable reactive energy. Reactive energy consumption may come from a factory or a production unit.

## Construction

- Power from 17.5 to 900 kVar.
- Harmonics from 0 to 100% in 4 stages: PFC41, PFC42, PFC43, PFC44.
- Cable input at the bottom (can be the top if required).
- Base plate optional
- Thermal regulation with fan (depending on equipment).
- 6 or 12 output power factor correction regulator depending on the model, with alarm relay.

## General characteristics

- Self-healing capacitors.
- Capacitor cut off from the automatic circuit in case of removal.
- Steel panel enclosure colour RAL 7035.
- IP rating IP20, IP30 depending on model.
- Rated voltage: 400 V three-phase.
- Rated frequency: 50 Hz.
- Operating temperature: -5°C to 40°C.
- Tolerance on capacitor capacity value: -5, +5%.
- Discharge device on each bank: < 50 V after 1 minute.
- Capacitor internal connection: delta.

# SYSTEM DESCRIPTION

## PFC system schematic diagram

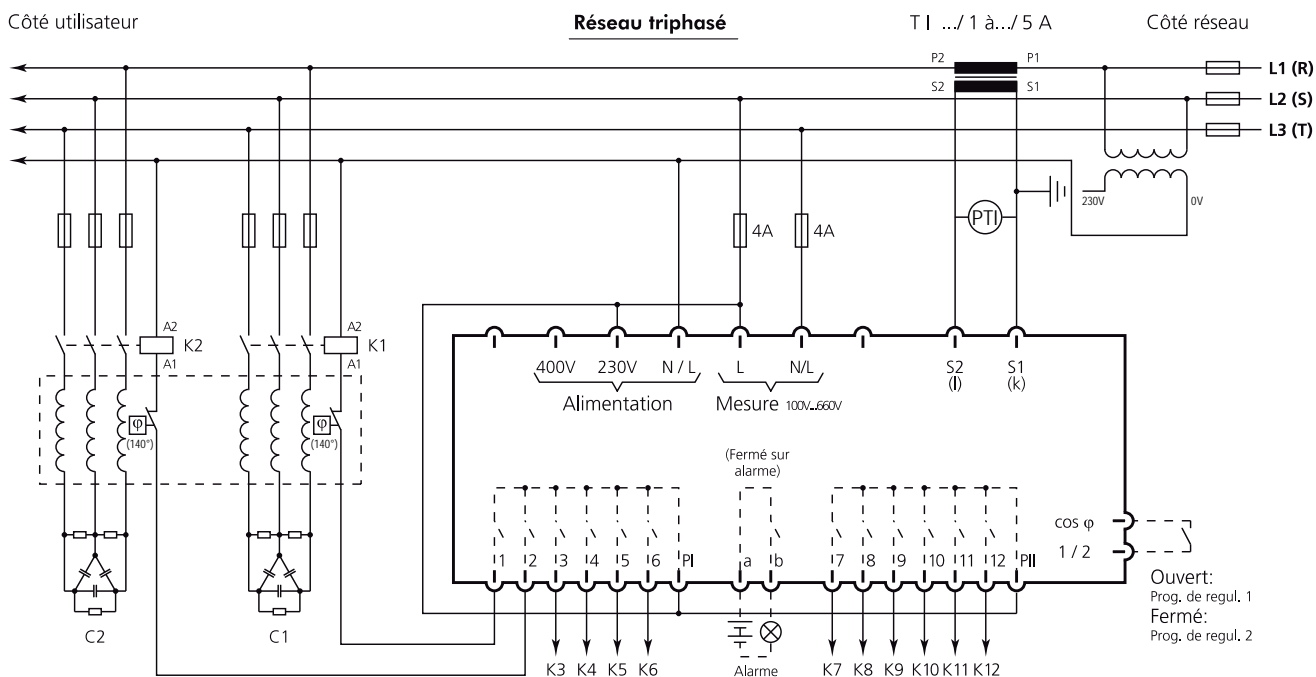

### Wiring diagram with regulator *COSYS R 12H*

We would advise fitting a PTI (current transformer automatic short-circuiter) to the current transformer secondary to prevent any electrical risks when the current transformer is disconnected (current transformer and PTI not supplied).



Failure to follow the installation instructions contained in this manual may compromise the operation and reliability of the PFC system.

## Recommendations relating to installation conditions

Recommended operating temperature: between 15°C and 35°C.

Relative humidity without condensation: 90% max.

Maximum operating altitude: 2,000 m

Take all necessary precautions to prevent splashes of water, paint or other fluids.

The enclosure conforms to protection rating IP20.

It is essential to ensure that there is a clearance of 50 cm above the PFC system to allow adequate ventilation.

## Connecting the input cables

The power is supplied to the terminals provided for this purpose.

The power, control and measurement cables should be connected in accordance with the standards in force and good practice.

The cable bushing plate should be refitted after the cable gland or other cable passage system has been fitted.

Failure to follow this instruction may seriously compromise the ventilation efficiency, reduce the cabinet's level of protection and cause the formation of hazardous material or objects.

## Upstream protection and connection cross section

The selection and co-ordination of the protection devices upstream of the PFC system depend on the nominal current and cable fitting conditions.

The protection devices upstream of the PFC system must conform to the safety standards in force.

The cross section of the should be adapted to the

power of the automatic PFC system. Cables should be selected according to the current values shown in the table below, which should be increased by a coefficient of 1.43 in accordance with CEI 60831-1.



# INSTALLATION

## Technical characteristics

### COSYS PFC41

Power supply	I nominal	Upstream protection		Figure n°		Height x Width x Depth		Weight	Regulator
		GG fuse (A)	Fuserbloc (A)	(without switch)	(with switch)	mm	mm with switch		
17.5	25	40	50	1	1	500x500x300	500x500x300	20	COSYS R 6H
30	43	80	100	1	1	500x500x300	500x500x300	500	COSYS R 6H
50	72	125	125	1	1	500x500x300	500x500x300	30	COSYS R 6H
75	108	160	160	2	2	811x600x286	811x600x286	40	COSYS R 6H
100	144	250	250	2	3	811x600x286	1211x600x311	50	COSYS R 6H
125	180	315	400	3	3	1211x600x311	1211x600x311	58	COSYS R 6H
150	217	315	400	3	3	1211x600x311	1211x600x311	65	COSYS R 6H
175	253	400	400	3	4	1211x600x311	2000x600x400	70	COSYS R 6H
200	289	500	630	3	4	1211x600x311	2000x600x400	80	COSYS R 6H
250	361	630	630	4	4	2000x600x400	2000x600x400	220	COSYS R 6H
300	433	630	630	4	4	2000x600x400	2000x600x400	240	COSYS R 6H
350	505	800	1250	4	4	2000x600x400	2000x600x600	260	COSYS R 12H
400	577	1000	1250	4	4	2000x600x400	2000x600x600	280	COSYS R 12H
450	650	1000	Consult us	4	5	2000x600x600	2000x(2x600)x600	400	COSYS R 12H
500	722	1250	Consult us	4	5	2000x600x600	2000x(2x600)x600	450	COSYS R 12H
550	794	1250	Consult us	5	5	2000x(2x600)x600	2000x(2x600)x600	480	COSYS R 12H
600	866	1250	Consult us	5	5	2000x(2x600)x600	2000x(2x600)x600	500	COSYS R 12H
650	938	1600	Consult us	5	5	2000x(2x600)x600	2000x(2x600)x600	520	COSYS R 12H
700	1010	1600	Consult us	5	5	2000x(2x600)x600	2000x(2x600)x600	540	COSYS R 12H
750	1083	1600	Consult us	5	5	2000x(2x600)x600	2000x(2x600)x600	550	COSYS R 12H
800	1155	1800	Consult us	5	5	2000x(2x600)x600	2000x(2x600)x600	680	COSYS R 12H
850	1227	1800	Consult us	5		2000x(2x600)x600		650	COSYS R 12H
900	1299	2000	Consult us	5		2000x(2x600)x600		720	COSYS R 12H

### COSYS PFC42

Power supply	I nominal	Upstream protection		Figure n°		Height x Width x Depth		Weight	Regulator
		GG fuse (A)	Fuserbloc (A)	(without switch)	(with switch)	mm	mm with switch		
17.5	25	40	50	3	3	1211x600x311	1211x600x311	38	COSYS R 6H
30	43	80	100	3	3	1211x600x311	1211x600x311	55	COSYS R 6H
50	72	125	125	3	3	1211x600x311	1211x600x311	80	COSYS R 6H
75	108	160	160	3	3	1211x600x311	1211x600x311	115	COSYS R 6H
100	144	250	250	3	3	1211x600x311	1211x600x311	150	COSYS R 6H
125	180	315	400	4	4	2000x800x400	2000x800x400	183	COSYS R 6H
150	217	315	400	4	4	2000x800x400	2000x800x400	215	COSYS R 6H
175	253	400	400	4	4	2000x800x400	2000x800x400	245	COSYS R 6H
200	289	500	630	4	4	2000x800x400	2000x800x400	280	COSYS R 6H
250	361	630	630	4	4	2000x800x400	2000x800x400	470	COSYS R 6H
300	433	630	630	4	4	2000x800x400	2000x800x400	540	COSYS R 6H
350	505	800	1250	4	5	2000x800x400	2000x800x600	610	COSYS R 12H
400	577	1000	1250	4	5	2000x800x400	2000x800x600	680	COSYS R 12H
450	650	1000	Consult us	5	5	2000x800x600	2000x(2x800)x600	850	COSYS R 12H
500	722	1250	Consult us	5	5	2000x800x600	2000x(2x800)x600	950	COSYS R 12H
550	794	1250	Consult us	5	5	2000x(2x800)x600	2000x(2x800)x600	1030	COSYS R 12H
600	866	1250	Consult us	5	5	2000x(2x800)x600	2000x(2x800)x600	1100	COSYS R 12H
650	938	1600	Consult us	5	5	2000x(2x800)x600	2000x(2x800)x600	1170	COSYS R 12H
700	1010	1600	Consult us	5	5	2000x(2x800)x600	2000x(2x800)x600	1240	COSYS R 12H
750	1083	1600	Consult us	5	5	2000x(2x800)x600	2000x(2x800)x600	1300	COSYS R 12H
800	1155	1800	Consult us	5	5	2000x(2x800)x600	2000x(2x800)x600	1480	COSYS R 12H
850	1227	1800	Consult us	5		2000x(2x800)x600		1500	COSYS R 12H
900	1299	2000	Consult us	5		2000x(2x800)x600		1620	COSYS R 12H

## Technical characteristics

### COSYS PFC43

Power supply Kvar	I nominal A	Upstream protection		Figure n°		Height x Width x Depth		Weight Kg	Regulator
		GG fuse (A)	Fuserbloc (A)	(without switch)	(with switch)	mm	mm with switch		
25	36	63	63	3	3	1211x600x311	1211x600x311	55	COSYS R 6H
50	72	125	125	3	3	1211x600x311	1211x600x311	80	COSYS R 6H
75	108	160	160	3	3	1211x600x311	1211x600x311	115	COSYS R 6H
100	144	250	250	3	3	1211x600x311	1211x600x311	150	COSYS R 6H
125	180	315	400	4	4	2000x800x500	2000x800x500	183	COSYS R 6H
150	217	315	400	4	4	2000x800x500	2000x800x500	215	COSYS R 6H
175	253	400	400	4	4	2000x800x500	2000x800x500	245	COSYS R 6H
200	289	500	630	4	4	2000x800x500	2000x800x500	280	COSYS R 6H
250	361	630	630	4	4	2000x800x500	2000x800x500	470	COSYS R 6H
300	433	630	630	4	4	2000x800x500	2000x800x500	540	COSYS R 6H
350	505	800	1250	4	5	2000x800x500	2000x800x600	610	COSYS R 6H
400	577	1000	1250	4	5	2000x800x500	2000x800x600	680	COSYS R 12H
450	650	1000	Consult us	5	5	2000x800x600	2000x(2x800)x600	850	COSYS R 12H
500	722	1250	Consult us	5	5	2000x800x600	2000x(2x800)x600	950	COSYS R 12H
550	794	1250	Consult us	5	5	2000x(2x800)x600	2000x(2x800)x600	1030	COSYS R 12H
600	866	1250	Consult us	5	5	2000x(2x800)x600	2000x(2x800)x600	1100	COSYS R 12H
650	938	1600	Consult us	5	5	2000x(2x800)x600	2000x(2x800)x600	1170	COSYS R 12H
700	1010	1600	Consult us	5	5	2000x(2x800)x600	2000x(2x800)x600	1240	COSYS R 12H
750	1083	1600	Consult us	5	5	2000x(2x800)x600	2000x(2x800)x600	1300	COSYS R 12H
800	1155	1800	Consult us	5	5	2000x(2x800)x600	2000x(2x800)x600	1480	COSYS R 12H
850	1227	1800	Consult us	5		2000x(2x800)x600		1500	COSYS R 12H
900	1299	2000	Consult us	5		2000x(2x800)x600		1620	COSYS R 12H

### COSYS PFC44

Power supply Kvar	I nominal A	Upstream protection		Figure n°		Height x Width x Depth		Weight Kg	Regulator
		GG fuse (A)	Fuserbloc (A)	(without switch)	(with switch)	mm	mm with switch		
17.5	25	40	Consult us	3	3	1211x600x311	1211x600x311	38	COSYS R 6H
30	43	80	Consult us	3	3	1211x600x311	1211x600x311	55	COSYS R 6H
50	72	125	Consult us	3	3	1211x600x311	1211x600x311	80	COSYS R 6H
75	108	160	Consult us	3	3	1211x600x311	1211x600x311	115	COSYS R 6H
100	144	250	Consult us	3	3	1211x600x311	1211x600x311	150	COSYS R 6H
125	180	315	Consult us	4	4	2000x800x400	2000x800x400	185	COSYS R 6H
150	217	315	Consult us	4	4	2000x800x400	2000x800x400	215	COSYS R 6H
175	253	400	Consult us	4	4	2000x800x400	2000x800x400	245	COSYS R 6H
200	289	500	Consult us	4	4	2000x800x400	2000x800x400	280	COSYS R 6H
250	361	630	Consult us	4	4	2000x800x400	2000x800x400	470	COSYS R 6H
300	433	630	Consult us	4	4	2000x800x400	2000x800x400	540	COSYS R 6H
350	505	800	Consult us	4	5	2000x800x400	2000x800x600	610	COSYS R 6H
400	577	1000	Consult us	4	5	2000x800x400	2000x800x600	680	COSYS R 12H
450	650	1000	Consult us	5	5	2000x800x600	2000x(2x800)x600	850	COSYS R 12H
500	722	1250	Consult us	5	5	2000x800x600	2000x(2x800)x600	950	COSYS R 12H
550	794	1250	Consult us	5	5	2000x(2x800)x600	2000x(2x800)x600	1030	COSYS R 12H
600	866	1250	Consult us	5	5	2000x(2x800)x600	2000x(2x800)x600	1100	COSYS R 12H
650	938	1600	Consult us	5	5	2000x(2x800)x600	2000x(2x800)x600	1170	COSYS R 12H
700	1010	1600	Consult us	5	5	2000x(2x800)x600	2000x(2x800)x600	1240	COSYS R 12H
750	1083	1600	Consult us	5	5	2000x(2x800)x600	2000x(2x800)x600	1300	COSYS R 12H
800	1155	1800	Consult us	5	5	2000x(2x800)x600	2000x(2x800)x600	1480	COSYS R 12H
850	1227	1800	Consult us	5		2000x(2x800)x600		1500	COSYS R 12H
900	1299	2000	Consult us	5		2000x(2x800)x600		1620	COSYS R 12H

# INSTALLATION

**Figure 1**

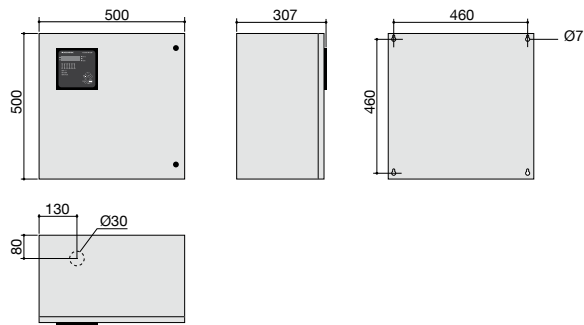

**Figure 2**

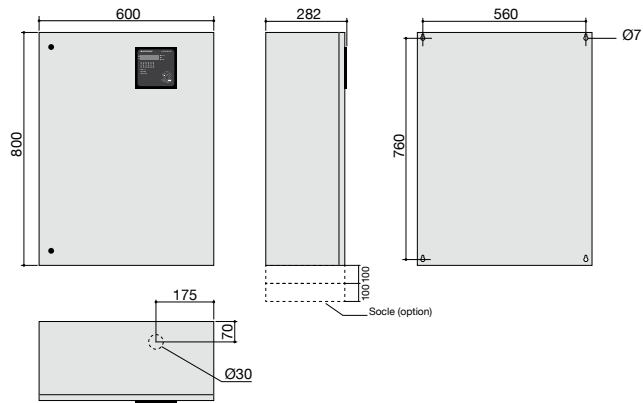

**Figure 3**

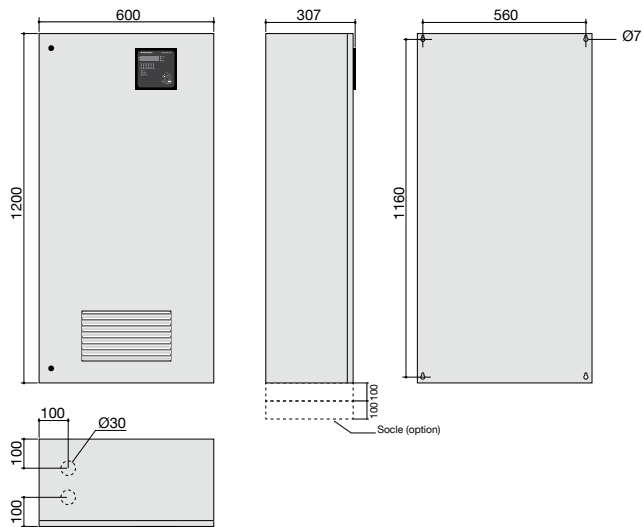

Figure 4

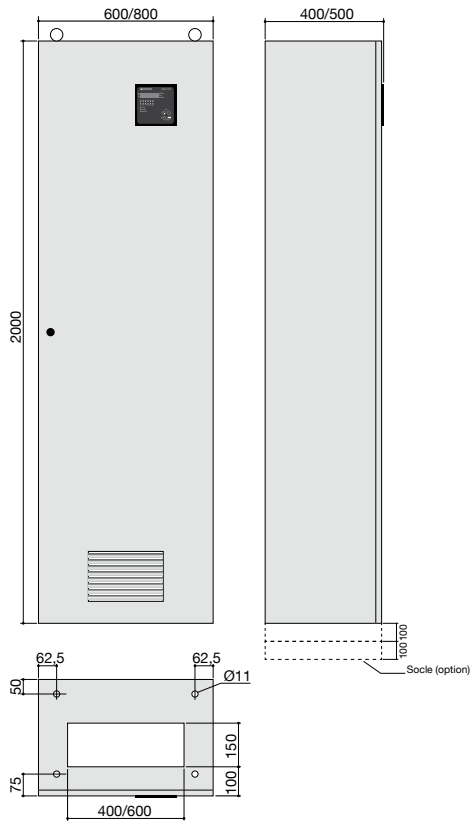
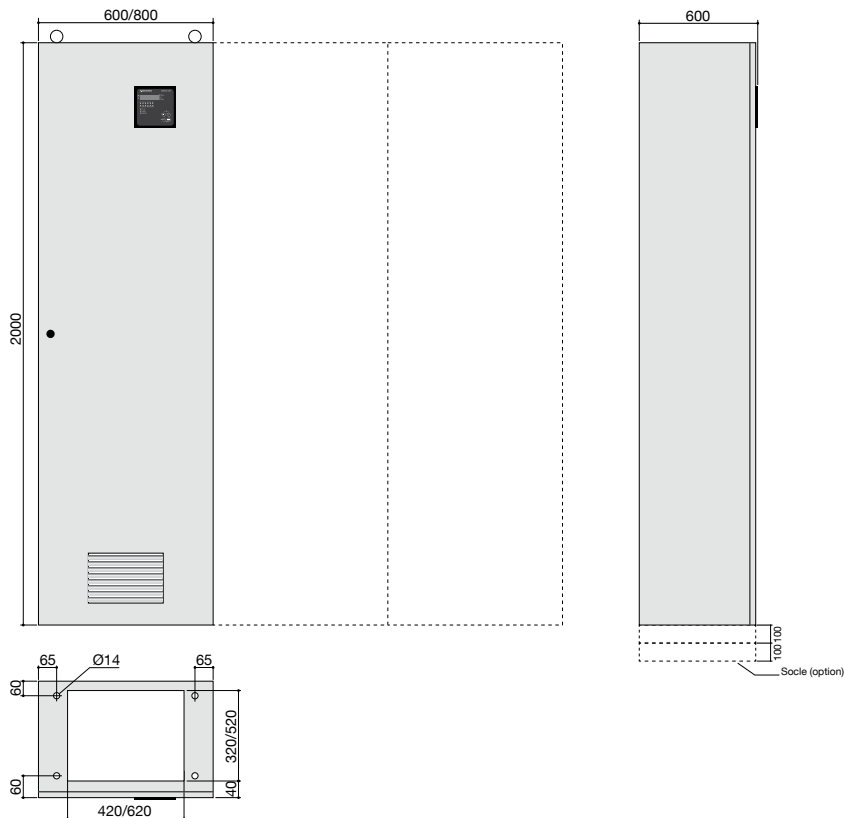

Figure 5



# COMMISSIONING AND MAINTENANCE

## Checking the equipment

Before commissioning the equipment, ensure that all connections are correctly tightened, as the terminals may become loose during transportation of the equipment from the production plant to the site (interrupter, switch etc.).

## Current transformers

Operation of an automatic PFC system requires the total current consumed by the installation to be measured.

- Correct connection

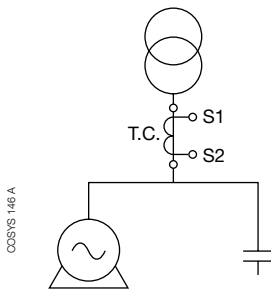

Caution When opening the secondary of a current transformer, dangerous voltage may appear. When handling the regulator, it is recommended the current transformer's secondary is short circuited by fitting a PTI.

## Powering up

Once the operations in the previous paragraph have been carried out, the equipment can be started by closing the upstream panel protection and the PFC system cabinet switch (depending on the model).

## Control relay configuration

The regulator is factory-configured according to the PFC system type and power.

When powered on for the first time, the regulator will automatically recognise the connection (order of the phases), the switching sequence and the reference current.

Only one parameter needs to be set by the user: value for the current transformer's primary side, see the regulator manual.

## Operating faults

The most common reasons for operational failure usually relate to the current transformer (see list below):

- Current transformer installed on the load.
- Current transformer installed on the PFC system supply cable
- Current transformer defective or unsuitable.

- Connection errors

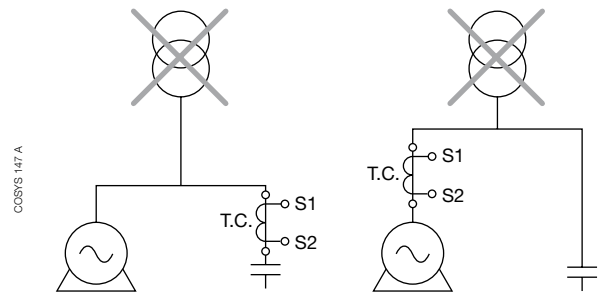

## Maintenance

Routine maintenance of this equipment involves periodically checking (at least once every year) the following components:

- Correct operation of the regulator
- Auxiliary circuit fuses
- Capacitor fuses
- Cleanliness of the ventilation grille and the filter to ensure proper ventilation of the enclosure
- Operation of the switches and retightening of their terminals
- Visual inspection of the capacitors by replacing those that are causing deforming of the upper part of the outer enclosure.

**SOCOMEc** can also offer:

- maintenance
- audit
- start-up
- training for your staff







## HEAD OFFICE

### **SOCOMECC GROUP**

S.A. SOCOMECC capital 11 149 200 €  
R.C.S. Strasbourg B 548 500 149  
B.P. 60010 - 1, rue de Westhouse  
F-67235 Benfeld Cedex - FRANCE

## INTERNATIONAL SALES DEPARTMENT

### **SOCOMECC**

1, rue de Westhouse - B.P. 60010  
F - 67235 Benfeld Cedex - FRANCE  
Tel. +33 (0)3 88 57 41 41 - Fax +33 (0)3 88 74 08 00  
info.scp.isd@socomec.com

[www.socomec.com](http://www.socomec.com)

Non contractual document. © 2012, Socomec SA. All rights reserved.

