



Электрические счетчики однофазные Socomes Countis E05 и Countis E06 - руководство по эксплуатации. Юниджет

Постоянная ссылка на страницу: <https://www.uni-jet.com/catalog/commutation/schetchiki/socomes-countis-e00.html>



**INSTRUCTION
MANUAL**

COUNTIS *E05/E06*

Single-phase energy meter
Direct - 40 A M-BUS

EN



COUNTIS E05



COUNTIS E06 - MID



[www.socomec.com/
en/countis-e0x](http://www.socomec.com/en/countis-e0x)

1. DOCUMENTATION	3
2. HAZARDS AND WARNINGS	4
2.1. Risk of electrocution, burns or explosion	4
2.2. Risk of damaging the unit	4
2.3. Responsibility	4
3. PRELIMINARY OPERATIONS	5
4. INTRODUCTION	6
4.1. Introducing the COUNTIS E05 / E 06	6
4.2. Functions	6
4.3. Front panels	6
4.4. LCD display	7
4.5. Dimensions	7
4.6. Electrical readings	8
4.6.1. Measurements	8
5. INSTALLATION	9
5.1. Recommendations and safety	9
5.2. DIN rail mounting	9
6. CONNECTION	10
6.1. Connecting the COUNTIS E05/E06	10
6.2. Connection to the electrical network and to the loads	10
7. MID COMPLIANCE	11
8. COMMUNICATION	12
8.1. General information	12
8.2. Recommendations	12
8.3. Communication structure	12
8.4. Communication tables	12
9. CONFIGURATION	13
9.1. Onscreen configuration	13
9.1.1. View of the entire "SETUP" menu	14
9.1.2. Detailed view of menu "SETUP"	15
9.1.3. Example: setting the communication address	16
10. USE	17
10.1. Detailed view of the "Main" menu	18
10.1.1. Detailed view of the partial energy meter	19
10.1.2. Starting up the partial energy meter	19
10.1.3. Stopping the partial energy meter	19
10.1.4. Resetting the partial energy meter to zero	20
11. DIAGNOSTICS MESSAGES	21
12. ASSISTANCE	21
13. CHARACTERISTICS	22
14. GLOSSARY OF ABBREVIATIONS	24

1. DOCUMENTATION

All documentation on the COUNTIS E05 / E06 is available online at:
www.socomec.com/en/countis-e0x



2. HAZARDS AND WARNINGS

The term "device" used in the paragraphs below refers to the COUNTIS E05 / E 06.

The assembly, use, servicing and maintenance of this equipment must only be carried out by trained, qualified professionals.

SOCOMEK shall not be held responsible for failure to comply with the instructions in this manual.

2.1. Risk of electrocution, burns or explosion

- Only duly authorised and qualified personnel may work or install/uninstall the device.
- The instructions are valid together with the specific instructions for the device.
- The devices are designed only for their intended purpose as set out in the instructions.
- Only accessories authorised or recommended by SOCOMEK may be used in association with the devices.
- Before proceeding with installation, maintenance, cleaning, disassembly, connection, or maintenance work, the device and system must be cut off from the mains to avoid electrocution and damaging the system and device.
- These devices are not designed to be repaired by the user.
- For any questions related to the disposal of the device, please contact SOCOMEK.

Failure to comply with the instructions of the device and this safety information can cause bodily injury, electric shock, burns, death or damage to property.

2.2. Risk of damaging the unit

To ensure that the unit operates correctly, make sure that:

- The unit is correctly installed.
- There is a maximum voltage at the voltage input terminals of 276 VAC phase-neutral
- The network frequency indicated on the device is observed: 50 or 60 Hz.
- There is a maximum current of 40 A at the current input terminals (I1).

Failure to respect these precautions could cause damage to the unit.

2.3. Responsibility

- Assembly, connection and use must be carried out in accordance with the installation standards currently in force.
- The unit must be installed in accordance with the rules given in this manual.
- Failure to observe the rules for installing this unit may compromise the device's intrinsic protection.
- The unit must be positioned within an installation which complies with the standards currently in force.
- Any cable which needs to be replaced may only be replaced with a cable having the correct rating.

3. PRELIMINARY OPERATIONS

To ensure the safety of staff and the equipment, it is vital to read and absorb the contents of these instructions thoroughly before commissioning.

Check the following points as soon as you receive the package containing the unit:

- The packaging is in good condition
- The unit has not been damaged during transportation
- The device reference number conforms to your order
- The package includes:
 - 1 device
 - 1 sealing kit (for COUNTIS E06)
 - 1 Quick Start guide

4. INTRODUCTION

4.1. Introducing the COUNTIS E05 / E 06

The COUNTIS E05 and E06 are modular active and reactive electrical energy meters that display consumed energy. They are designed for single-phase networks and allow a direct connection of up to 40 A. They are equipped with an M-BUS communication Bus.

4.2. Functions

- Measures and displays total and partial energy
- Dual tariff management: T1 / T2
- Electrical parameter measurements: I, U, V, f
- Power, power factor
- M-Bus communication
- MID version (according to reference)

Description	Reference
COUNTIS E05	4850 3041
COUNTIS E06 - Version MID	4850 3042

4.3. Front panels

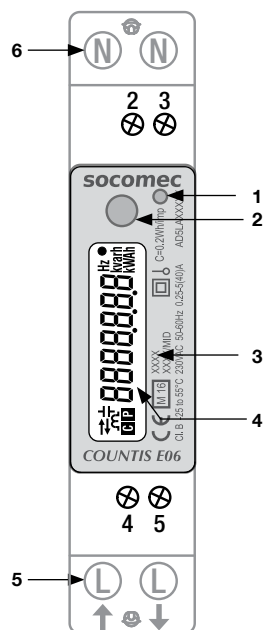
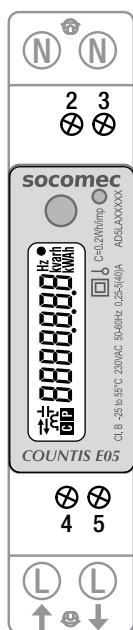

1. Metrological LED
2. ENTER key
3. Information relating to MID certification
4. LCD display
5. Single-phase network connection
6. Neutral connection

4.4. LCD display

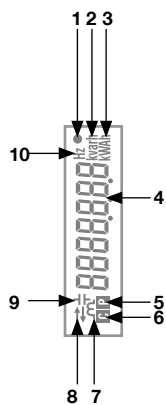

1. Active pulse output
2. Unit of measure
3. Unit of measure
4. Main zone (In the case of a Code XX: corrupt metrological settings, return to Manufacturer.)
5. Value of the partial meter Flashing = meter stopped
6. Active communication
7. Inductive value
8. Imported (→) or exported (←) energy or power
9. Capacitive value
10. Unit of measure

4.5. Dimensions

Dimensions: in/mm

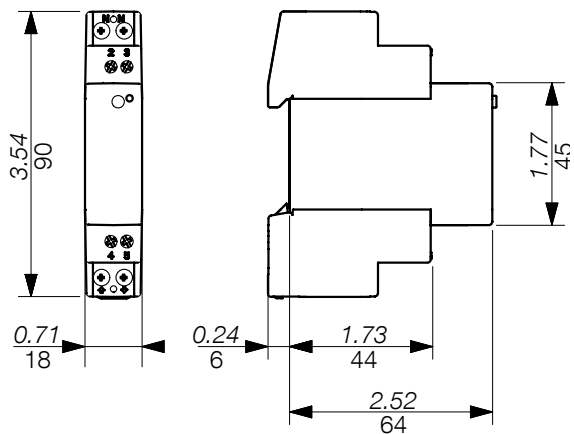

4.6. Electrical readings

4.6.1. Measurements

Settings vary by model.

Realtime values	Symbol	Unit of measure	LCD display	Via communication
Neutral voltage	V	V	●	●
Current	I	A	●	●
Power factor	PF			●
Apparent power	S	kVA		●
Active power	P	kW	●	●
Reactive power	Q	kvar	●	●
Frequency	f	Hz	●	
Direction of current	↻		●	
Logged data				
Total active, reactive energy	Ea, Er	kWh, kvarh	●	●
Total active and reactive energy for each tariff (T1/T2)	Ea, Er	kWh, kvarh	●	●
Partial active and reactive energy	Ea, Er	kWh, kvarh	●	●
Miscellaneous				
Current tariff	T	1/2	●	●
Partial meters	P	START/STOP	●	
State of the pulse output	●	Active / inactive	●	

5. INSTALLATION

The paragraphs below describe how to install the device.

5.1. Recommendations and safety

Refer to the safety instructions (section "2. Hazards and warnings", page 4)

- Keep away from electromagnetic interference generator systems,
- Avoid vibrations with accelerations greater than 1 g for frequencies lower than 60 Hz.

5.2. DIN rail mounting

The COUNTIS E05/E06 can be mounted on a 35-mm DIN rail (EN 60715TM35). They must be used inside electrical cabinets.

6. CONNECTION

6.1. Connecting the COUNTIS E05/E06

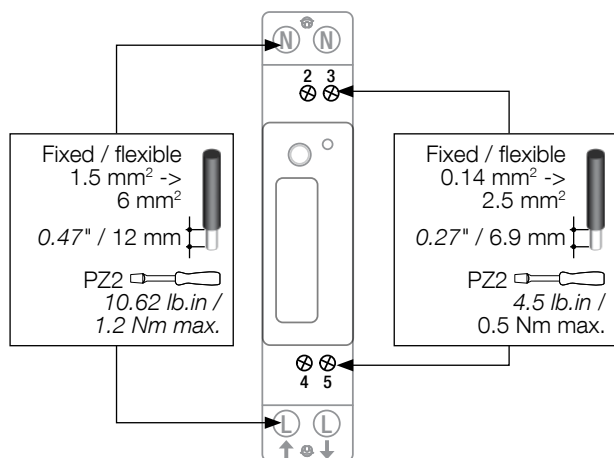

6.2. Connection to the electrical network and to the loads

The COUNTIS E05/E06 are intended for single-phase networks with neutral.

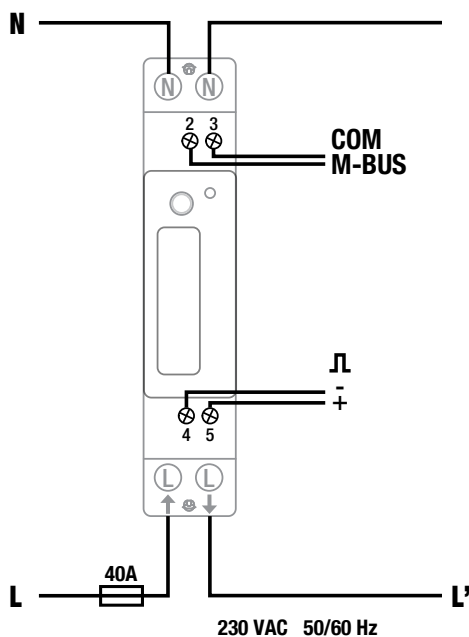

M-Bus

2-3: M-Bus connection

Pulse output

4: -
5: +

Optocoupler pulse outputs

Terminals 4-5 must be supplied with voltage between 5 and 27 VDC (27mA max)

Network

L: ↑ : Phase input
L': ↓ : Phase output
N: Neutral connection

7. MID COMPLIANCE

The following points must be taken into consideration to ensure that the device is used in compliance with directive MID 2014/32/EU:

- **Type of network**
COUNTIS E06 meters comply with the MID directive for connection to networks: 1P+N (see "6.2. Connection to the electrical network and to the loads", page 10)
- **Fitting terminal covers**
After connecting the device, ensure that the terminal covers are fitted properly and secured by the plastic seals provided with the device.
- **Communication**
The information provided via the M-BUS COM is transmitted for information only and has no legal value.
- **MID Declaration of Conformity**
The MID Declaration of Conformity is available on the website: www.socomec.com/en/countis-e0x

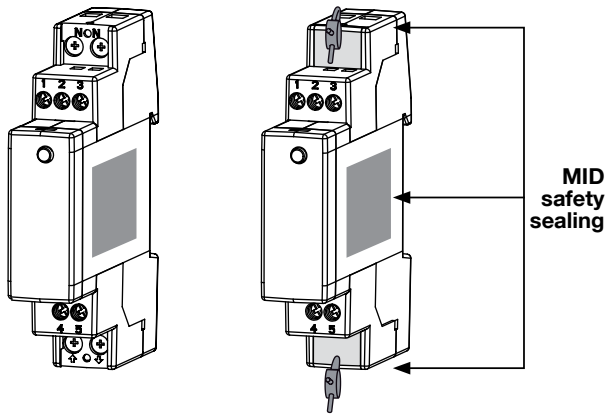

8. COMMUNICATION

8.1. General information

In a standard configuration, an M-BUS connection is used to connect 250* devices to a PC or a controller over a distance of 1000 metres**.

* depending on the M-BUS capacity

** depending on the number of devices and the communication speed

M-BUS cabling

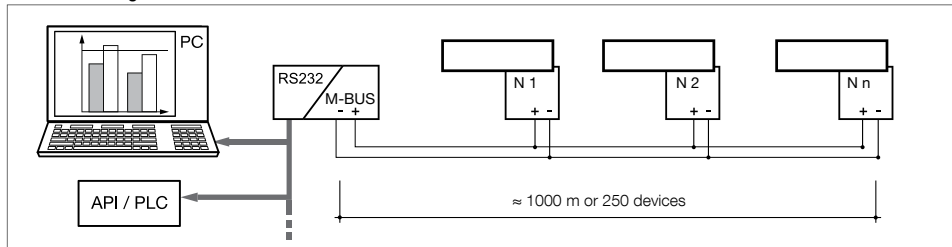

Cabling with repeater

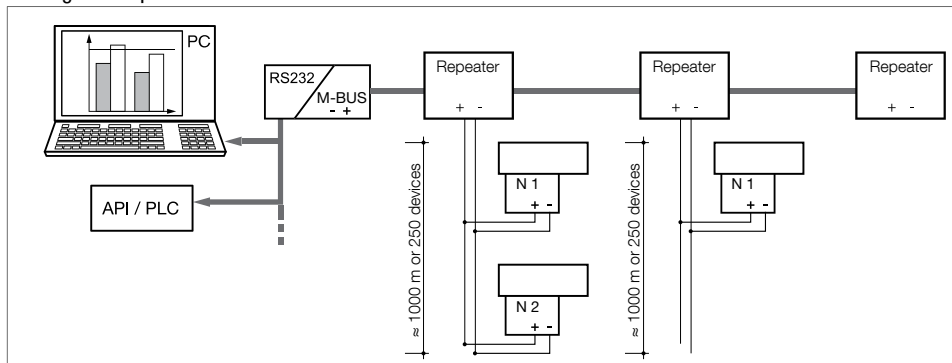

8.2. Recommendations

Use a non-shielded JYSTY Nx2x0.8 mm twisted pair (0.5 mm²).

If the distance of 1000 m is exceeded and/or the number of devices is greater than 250, add a repeater to allow additional devices to be connected.

If there are more than 250 units, use the secondary address only.

8.3. Communication structure

The device communicates via an M-BUS protocol which involves a master/slave dialogue. The COUNTIS units (slaves) are compatible with the 2 primary and secondary addressing modes. You can configure the primary and secondary addressing modes via the device's interface.

8.4. Communication tables

The communication tables and relevant notes are available online on the COUNTIS E05 / E06 documentation page at:

www.socomec.com/en/countis-e0x



9. CONFIGURATION

The device can be configured directly from the COUNTIS E05 / E06 screen in programming mode or via the communication link. The paragraphs below describe configuring using the screen.

9.1. Onscreen configuration

From the screen, go to programming mode to change your communication settings. How to browse through the programming mode is described in the following stages:

Function	Where	Buttons	Press
Switch pages within a menu	Every page within a menu		Realtime
Go to SETUP menu	Menu page SETUP		> 3 sec
Change a value/digit	SETUP pages		realtime
Confirm a value/digit	SETUP pages		> 3 sec
Exit SETUP menu	SAVE screen in the SETUP menu		> 3 sec
Start/stop the displayed partial meter	Partial meter menu		> 3 sec
Reset the displayed partial meter to zero	Partial meter menu		> 3 sec

9.1.1. View of the entire "SETUP" menu

In the SETUP menu, press "●" for 3 seconds to put the device into programming mode.

Press "●" to go to the different screens:

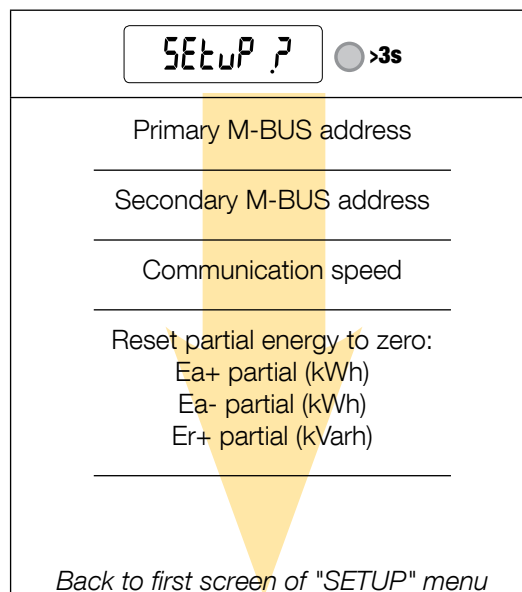

9.1.2. Detailed view of menu "SETUP"

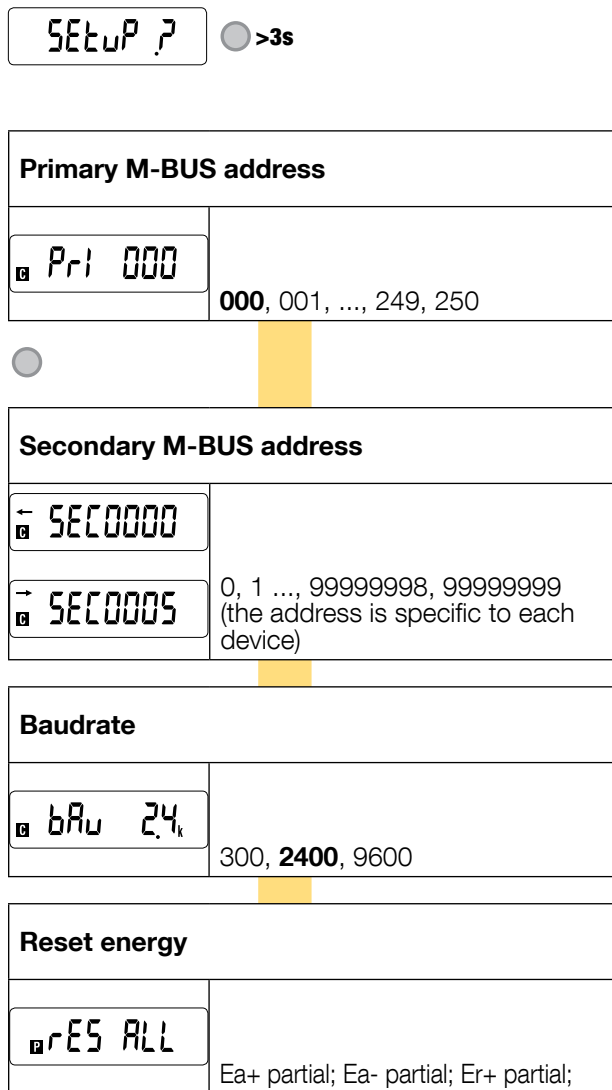

Back to first screen of "SETUP" menu

XX = default value

9.1.3. Example: setting the communication address

In "SETUP" mode (see page 15), go to the "Primary M-BUS address" screen

Example: changing the communication address to 243.

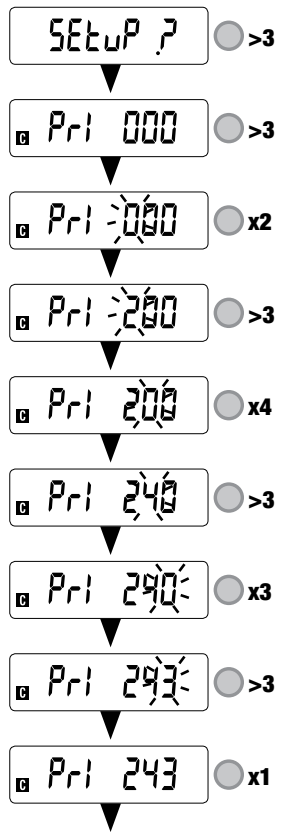

Secondary M-BUS address
Communication speed
Reset partial energy
to zero

10. USE

Electrical measurements or information within a menu can be accessed by pressing 1x on "●".

The associated measurements are described in the table below:

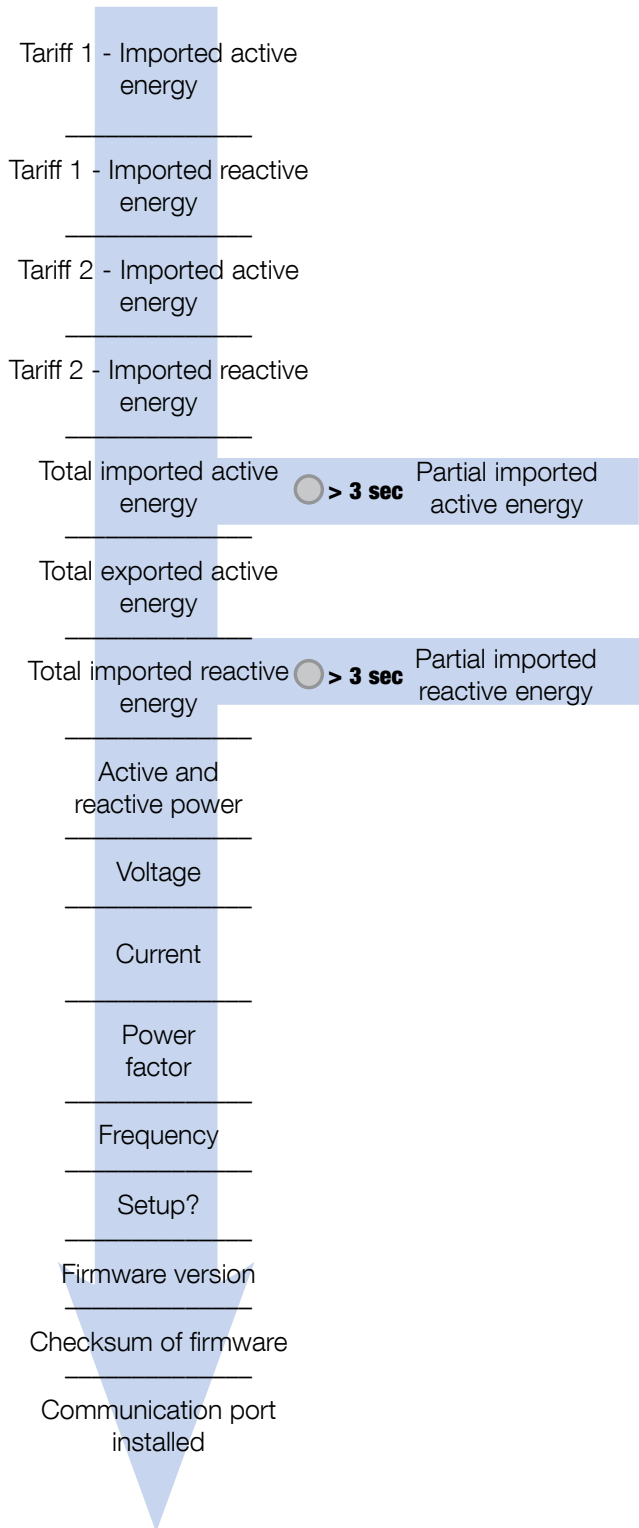

10.1. Detailed view of the "Main" menu

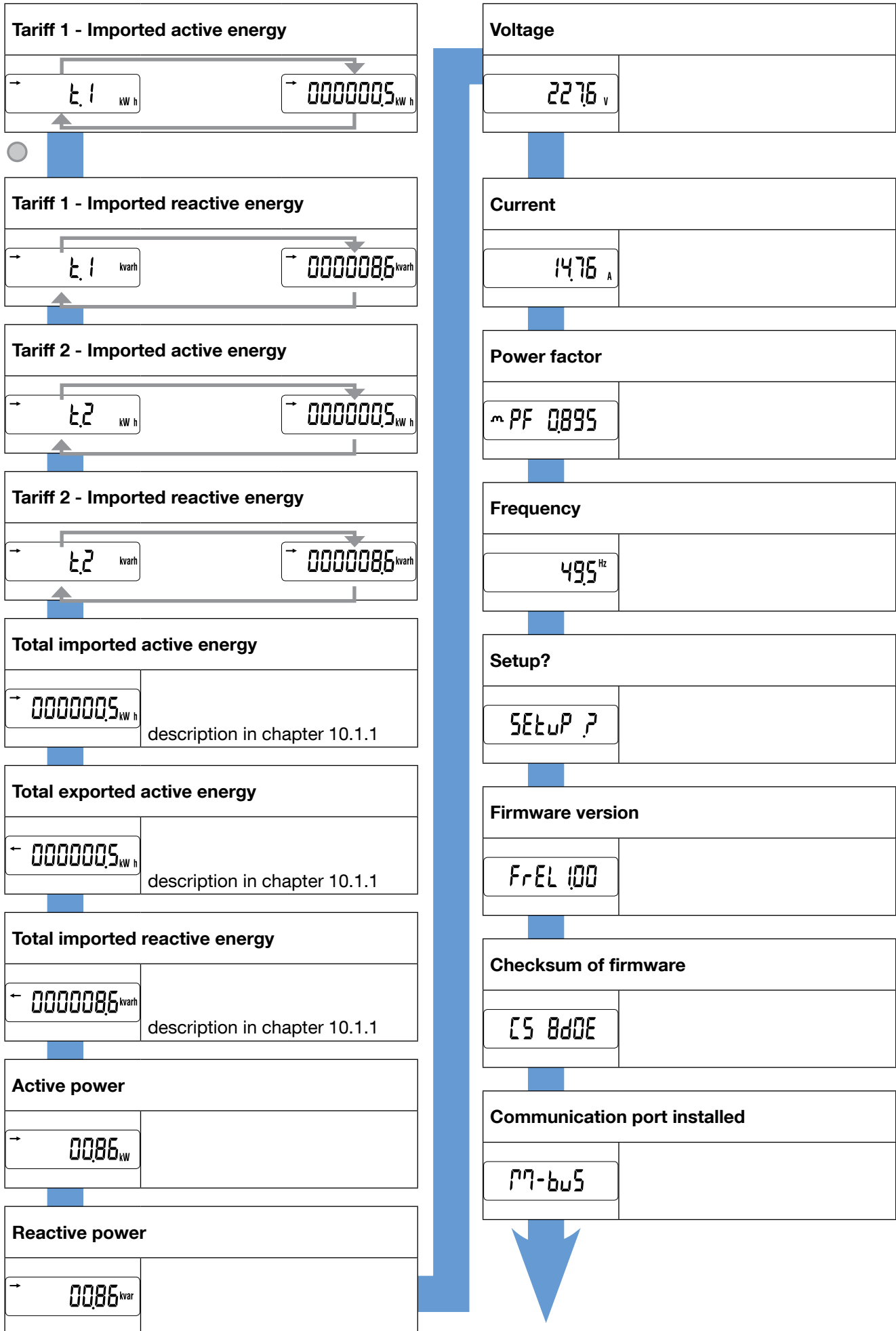

10.1.1. Detailed view of the partial energy meter

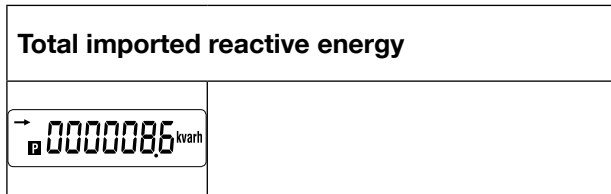
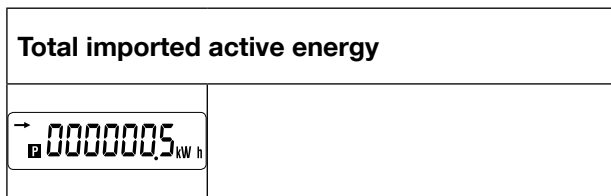

10.1.2. Starting up the partial energy meter

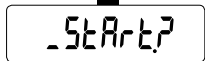
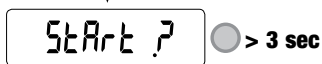

10.1.3. Stopping the partial energy meter

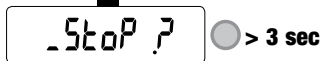
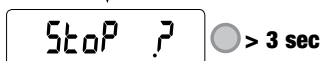

10.1.4. Resetting the partial energy meter to zero

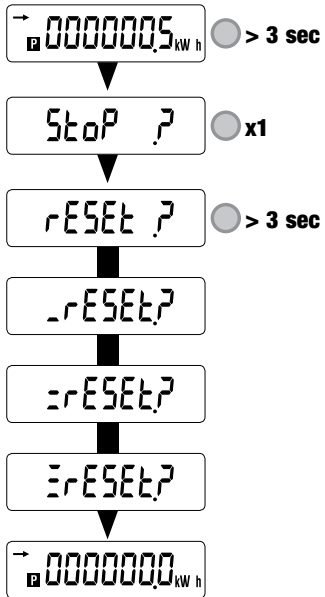

11. DIAGNOSTICS MESSAGES

The following message appears if there are connection or malfunction errors.

11.1. Malfunction

CODE

- If you see this message, Code xx, the meter has malfunctioned and must be replaced.

12. ASSISTANCE

Causes	Solutions
Device not working	Check the neutral and phase cable connections
Error message	Check the meter is working OK

13. CHARACTERISTICS

GENERAL FEATURES	
Compliant with	European EMC Directive No. 2014/30/EU dated 26/02/2014 LV Directive No. 2014/35/EU dated 26/02/2014 Measuring Instrument Directive MID No. 2014/32/EU dated 26/02/2014 EN50470-1/-3 IEC 62053-21/-23
Frequency	50 and 60 Hz (\pm 1 Hz)
Power supply	Self-supplied
Rated dissipated power (Wmax.)	1.5 VA - 0.5 W
FEATURES	
Single-phase connectivity	2 wires 230
Stores energy readings and settings	In the EEPROM memory
Identifies display of tariffs	T1 and T2
CURRENT MEASUREMENTS	
Type	Single-phase - direct 40 A
Input consumption	0.5VA max. per phase
Startup current (Ist)	20mA
Minimum current (Imin)	0.25A
Transition current (Itr)	0.5A
Reference current (Iref)	5A
Permanent overload (Imax)	40A
Intermittent overload	30 Imax for 1/2 cycle
OVERLOAD CAPACITY	
DC voltage Un	276 VAC
Realtime voltage Un (1 s)	300 VAC
DC current Imax	40 A
Realtime current Imax	30 Imax for 1/2 cycle
VOLTAGE MEASUREMENTS	
Range of measurement	230 \pm 20%
Power consumption	7.5VA max
Permanent overload	280V phase-neutral
FREQUENCY MEASUREMENT	
Frequency measurement	45-65 Hz
ENERGY MEASUREMENT	
Active	Yes
Reactive	Yes
Total and partial reading	Yes
MID metering	Bidirectional with single-phase
Resolution	10 Wh, 10 varh
ENERGY ACCURACY	
Active energy Ea+	Class B (EN 50470-3) E16 Class 1 (EN 62053-21)
Reactive energy Er+	Class 2 (EN 62053-23)
TARIFF for Ea+	
Tariff management	Yes (via communication)

Number of tariffs managed	2
METROLOGICAL LED (Ea+)	
Pulse value	5000 pulses / kWh
Colour	Red
PULSE OUTPUT	
Type	Opto-isolated - 5 ... 27VDC 27mA according to EN 62053-31
Pulse weight	100 Wh
DISPLAY	
Type	7-digit LCD with backlight
Refresh time	0.5 s
Backlight activation time	10 s
Active energy: 1 display, 7-digit	000000.0 - 999999.9 kWh
Reactive energy: 1 display, 7-digit	000000.0 - 999999.9 kvarh
Realtime active power: 1 display, 4-digit	00.00 - 99.99 kW
Realtime reactive power: 1 display, 4-digit	00.00 - 99.99 kvar
Realtime voltage: 1 display, 4-digit	000.0 ... 999.9 V
Realtime current: 1 display, 4-digit	00.00 ... 99.99 A
Power factor: 1 display, 4-digit	0.001-1.000
Frequency: 1 display, 4-digit	45.00-65.00 Hz
COMMUNICATION	
M-BUS	2 wires + shielding/ half duplex
Protocol	M-BUS
Baudrate	300, 2400, 9600 bps
Load unit	1
SAVING	
Energy registers	In FRAM memory
ENVIRONMENTAL CONDITIONS	
Mechanical environment	M1
Electromagnetic environment	E2
Operating temperature range	-25°C to +55°C
Storage temperature	-25°C to 75°C
Humidity	≤ 80%
Installation	Internal (box/cabinet)
Vibrations	±0.075 mm
HOUSING	
Dimensions W x H x D (mm)	Modular - width of 2 modules (DIN 43880) 18 x 90 x 70
Installation	On DIN rail (EN 60715)
Connection capacity, tightening torque	See chapter "6. Connection", page 10
Protection index	Front: IP51 - casing: IP20
Insulation class	Class II (EN 50470-1)
Weight	80 g

14. GLOSSARY OF ABBREVIATIONS

FrEL	Metrological firmware version
CS	Checksum of metrological firmware
t.1	Tariff 1
t.2	Tariff 2
tot	Total menu
SEtuP?	Setup menu
Pr1	Primary M-BUS address
SEC.	Secondary M-BUS address
bAu	Communication speed in bauds (bits per second)
rES ALL	Reset partial energy
SAVE?	Confirm selection
Y	Save and exit
N	Exit without saving
C	Continue without saving

CORPORATE HQ CONTACT:
SOCOMECSAS
1-4 RUE DE WESTHOUSE
67235 BENFELD, FRANCE

www.socomec.com



545867A - EN - 04/17

 **socomec**
Innovative Power Solutions