



Электрические счетчики однофазные Socomes Countis E03 и Countis E04 - руководство по эксплуатации. Юниджет

Постоянная ссылка на страницу: <https://www.uni-jet.com/catalog/commutation/schetchiki/socomes-countis-e00.html>



**INSTRUCTION
MANUAL**

COUNTIS *E03/E04*

Single-phase energy meter
Direct - 40 A Modbus

EN



COUNTIS E03



COUNTIS E04 - MID



[www.socomec.com/
en/countis-e0x](http://www.socomec.com/en/countis-e0x)

| | |
|--|----|
| 1. DOCUMENTATION | 3 |
| 2. HAZARDS AND WARNINGS | 4 |
| 2.1. Risk of electrocution, burns or explosion | 4 |
| 2.2. Risk of damaging the unit | 4 |
| 2.3. Responsibility | 4 |
| 3. PRELIMINARY OPERATIONS | 5 |
| 4. INTRODUCTION | 6 |
| 4.1. Introducing the COUNTIS E03 / E04 | 6 |
| 4.2. Functions | 6 |
| 4.3. Front panels | 6 |
| 4.4. LCD display | 7 |
| 4.5. Dimensions | 7 |
| 4.6. Electrical readings | 8 |
| 4.6.1. Measurements | 8 |
| 5. INSTALLATION | 9 |
| 5.1. Recommendations and safety | 9 |
| 5.2. DIN rail mounting | 9 |
| 6. CONNECTION | 10 |
| 6.1. Connecting the COUNTIS E03/04 | 10 |
| 6.2. Connection to the electrical network and to the loads | 10 |
| 7. MID COMPLIANCE | 11 |
| 8. COMMUNICATION | 12 |
| 8.1. General information | 12 |
| 8.2. RS485 rules | 12 |
| 8.3. Communication structure | 13 |
| 8.4. Communication tables | 13 |
| 9. CONFIGURATION | 14 |
| 9.1. On-screen configuration | 14 |
| 9.1.1. View all of the menu "SETUP" | 14 |
| 9.1.2. Detailed view of menu "SETUP" | 15 |
| 9.1.3. Example: setting the communication address | 16 |
| 10. USE | 17 |
| 10.1. Detailed view of the Main menu | 18 |
| 10.1.1. Detailed view of the partial energy meter | 19 |
| 10.1.2. Starting up the partial energy meter | 19 |
| 10.1.3. Stopping the partial energy meter | 19 |
| 10.1.4. Resetting the partial energy meter to zero | 20 |
| 11. DIAGNOSTICS MESSAGES | 21 |
| 12. ASSISTANCE | 21 |
| 13. CHARACTERISTICS | 22 |

1. DOCUMENTATION

All documentation on the COUNTIS E03 / E04 is available online at:
www.socomec.com/en/countis-e0x



2. HAZARDS AND WARNINGS

The term "device" used in the paragraphs below refers to the COUNTIS E03 / E04.

The assembly, use, servicing and maintenance of this equipment must only be carried out by trained, qualified professionals.

SOCOMEK shall not be held responsible for failure to comply with the instructions in this manual.

2.1. Risk of electrocution, burns or explosion

- Only duly authorised and qualified personnel may work or install/uninstall the device.
- The instructions are valid together with the specific instructions for the device.
- The device is designed only for its intended purpose as set out in the instructions.
- Only accessories authorised or recommended by SOCOMEK may be used in association with the device.
- Before proceeding with installation, maintenance, cleaning, disassembly, connection, or maintenance work, the device and system must be cut off from the mains to avoid electrocution and damaging the system and device.
- This device is not designed to be repaired by the user.
- For any questions related to the disposal of the device, please contact SOCOMEK.

Failure to comply with the instructions of the device and this safety information can cause bodily injury, electric shock, burns, death or damage to property.

2.2. Risk of damaging the unit

To ensure that the unit operates correctly, make sure that:

- The unit is correctly installed.
- There is a maximum voltage at the voltage input terminals of 276 VAC phase-neutral
- The network frequency indicated on the device is observed: 50 or 60 Hz.
- a maximum current 40 A at the current input terminal.

Failure to respect these precautions could cause damage to the unit.

2.3. Responsibility

- Assembly, connection and use must be carried out in accordance with the installation standards currently in force.
- The unit must be installed in accordance with the rules given in this manual.
- Failure to observe the rules for installing this unit may compromise the device's intrinsic protection.
- The unit must be positioned within an installation which complies with the standards currently in force.
- Any cable which needs to be replaced may only be replaced with a cable having the correct rating.

3. PRELIMINARY OPERATIONS

To ensure the safety of staff and the equipment, it is vital to read and absorb the contents of these instructions thoroughly before commissioning.

Check the following points as soon as you receive the package containing the unit:

- The packaging is in good condition
- The unit has not been damaged during transportation
- The device reference number conforms to your order
- The package includes:
 - 1 device
 - 1 sealing kit (for COUNTIS E04)
 - 1 Quick Start guide

4. INTRODUCTION

4.1. Introducing the COUNTIS E03 / E04

The COUNTIS E03 and E04 are modular active and reactive electrical energy meters that display consumed energy. They are designed for single-phase networks and allow a direct connection of up to 40 A. They are equipped with a Modbus communication bus.

4.2. Functions

- Measures and displays total and partial energy
- Dual tariff management: T1 / T2
- Electrical parameter measurements: I, U, V, f
- Power, power factor
- RS 485 modbus communication
- MID version (according to reference)

| Description | Reference |
|---------------------------|-----------|
| COUNTIS E03 | 4850 3039 |
| COUNTIS E04 - Version MID | 4850 3040 |

4.3. Front panels

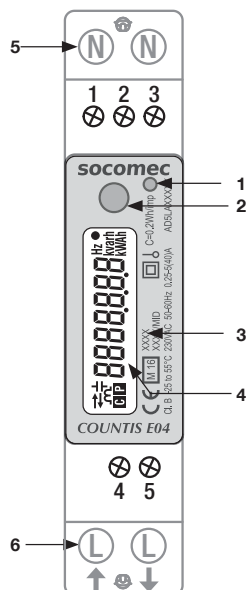
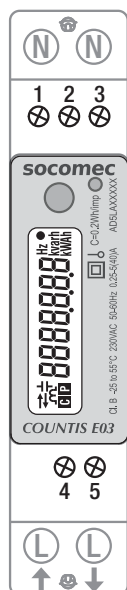

1. Metrological LED
2. ENTER key
3. Information relating to MID certification
4. LCD display
5. Neutral connection
6. Single-phase network connection

4.4. LCD display

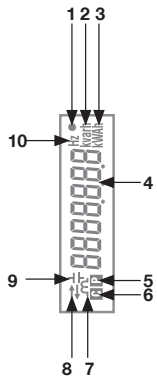

1. Active pulse output
2. Unit of measure
3. Unit of measure
4. Main zone (in the event of Code XX: metrological setting corrupt; return to manufacturer.)
5. Value of the partial meter Flashing = meter stopped
6. Active communication
7. Inductive value
8. Imported (→) or exported (←) energy or power
9. Capacitive value
10. Unit of measure

4.5. Dimensions

Dimensions: *in/mm*

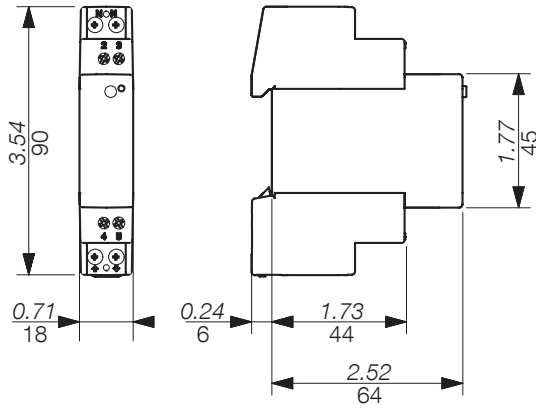

4.6. Electrical readings

4.6.1. Measurements

Settings vary by model.

| Realtime values | Symbol | Unit of measure | LCD display | Via communication |
|---|---------------|------------------------|--------------------|--------------------------|
| Neutral voltage | V | V | ● | ● |
| Current | I | A | ● | ● |
| Power factor | PF | | ● | ● |
| Apparent power | S | kVA | | ● |
| Active power | P | kW | ● | ● |
| Reactive power | Q | kvar | ● | ● |
| Frequency | f | Hz | ● | ● |
| Direction of current | ↔ | | ● | |
| Logged data | | | | |
| Total active and reactive energy | Ea, Er | kWh, kvarh | ● | ● |
| Total apparent energy | Eap | kVAh | | ● |
| Total reactive, inductive and capacitive energy | Er | kvarh | | ● |
| Total active and reactive energy for each tariff (T1/T2) | Ea, Er | kWh, kvarh | ● | ● |
| Total apparent energy for each tariff (T1/T2) | Eap | kVAh | | ● |
| Total reactive, inductive and capacitive energy for each tariff (T1/T2) | Er | kvarh | | ● |
| Partial active and reactive energy | Ea, Er | kWh, kvarh | ● | ● |
| Partial apparent energy | Eap | kVAh | | ● |
| Miscellaneous | | | | |
| Current tariff | T | 1/2 | ● | ● |
| Partial meters | P | START/STOP | ● | |
| Status of the pulse output | ● | Active / inactive | ● | |

5. INSTALLATION

The paragraphs below describe how to install the device.

5.1. Recommendations and safety

Refer to the safety instructions (section "2. Hazards and warnings", page 4)

- Keep away from electromagnetic interference generator systems,
- Avoid vibrations with accelerations greater than 1 g for frequencies lower than 60 Hz.

5.2. DIN rail mounting

The COUNTIS E03/E04 can be mounted on a 35-mm DIN rail (EN 60715TM35). They must be used inside electrical cabinets.

6. CONNECTION

6.1. Connecting the COUNTIS E03/04

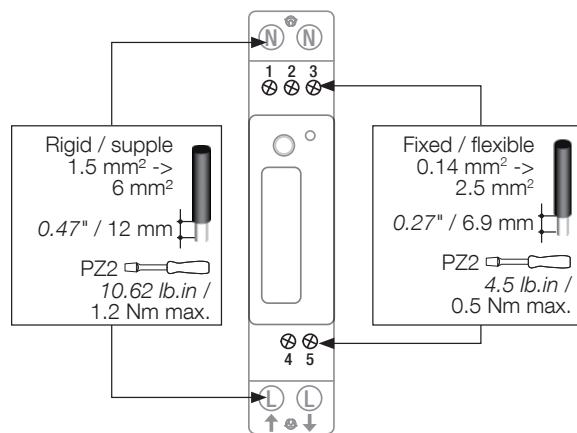

6.2. Connection to the electrical network and to the loads

The COUNTIS E03/E04 are intended for single-phase networks with neutral.

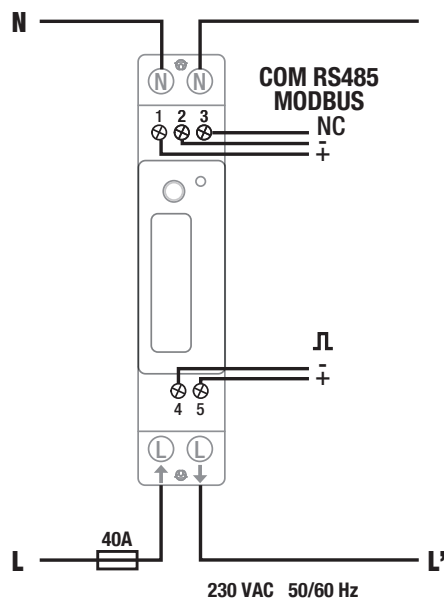

Modbus

1: +
2: -

3: NC (not connected). May be used for shielding continuity.

Pulse output

4: -
5: +

Optocoupler pulse outputs

Terminals 4-5 must be supplied with voltage between 5 and 27 VDC (27 mA max)

Network

L: ↑ : Phase input
L': ↓ : Phase output
N: Neutral connection

7. MID COMPLIANCE

The following points must be taken into consideration to ensure that the device is used in compliance with directive MID 2014/32/EU:

- **Type of network**
COUNTIS E04 meters comply with the MID directive for connection to networks: 1P+N (see "6.2. Connection to the electrical network and to the loads", page 10)
- **Fitting terminal covers**
After connecting the device, ensure that the terminal covers are fitted properly and secured by the plastic seals provided with the device.
- **RS485 communication**
The information provided via the RS485 COM is transmitted for information only and has no legal value.
- **MID Declaration of Conformity**
The MID Declaration of Conformity is available on the website: www.socomec.com/en/countis-e0x

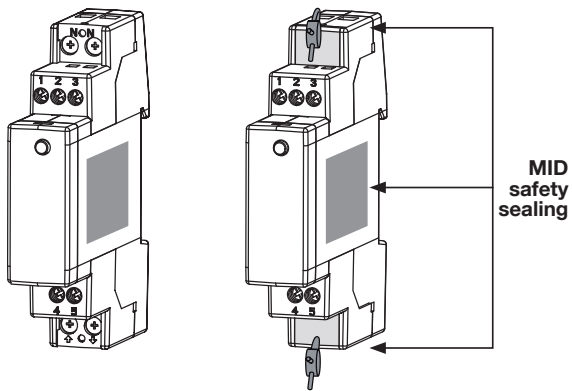

8. COMMUNICATION

8.1. General information

The Modbus communication available on the COUNTIS E03/04 communicates via an RS485 series link (2 or 3 wires) which is used to operate devices from a PC or an API.

In a standard configuration, an RS485 connection is used to connect 32 products to a PC or a controller over 1200 metres.

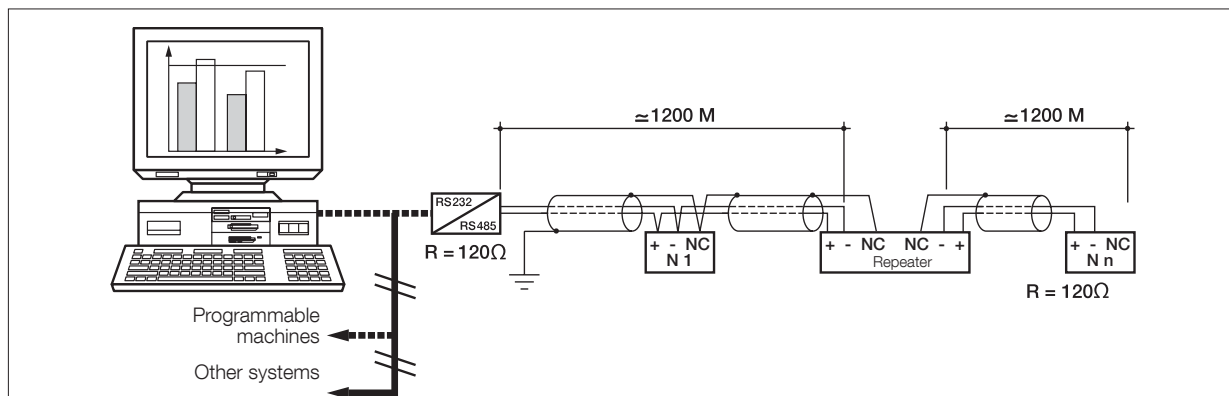
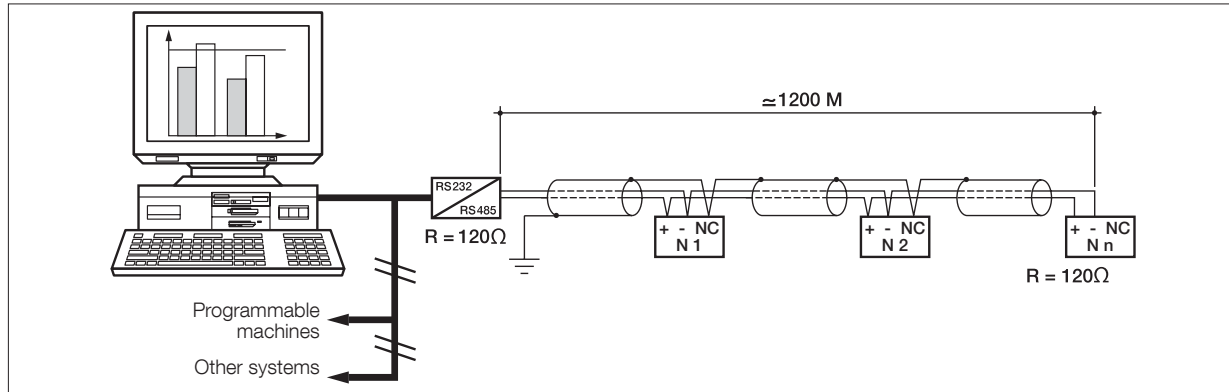

8.2. RS485 rules

A LIYCY shielded twisted pair must be used. We recommend using a shielded twisted pair with a general LIYCY-CY shielding in an environment where there is interference or in a very long network with a number of products.

If the distance of 1,200 m is exceeded and/or the number of products is greater than 32, a repeater must be added to enable additional products to be connected.

A 120 Ohm resistor must be fixed at both ends of the connection.

8.3. Communication structure

The device communicates via a Modbus protocol which involves a dialogue in accordance with a master/slave structure. The communication mode is the RTU (Remote Terminal Unit) mode with hexadecimal characters composed of at least 8 bits.

Modbus frame structure (master -> slave question):

| Slave address | Function code | Address | Number of words to be read | CRC 16 |
|---------------|---------------|----------------|----------------------------|----------------|
| <i>1 byte</i> | <i>1 byte</i> | <i>2 bytes</i> | <i>2 bytes</i> | <i>2 bytes</i> |

To comply with the modbus protocol, the inter-character time must be ≤ 3 silences.

This means the time for 3 characters to be emitted so that the message is processed by the COUNTIS E03/E04. In order to use the information correctly, you must use the modbus functions in accordance with the codes:

- 3: to read n words (maximum 128).
- 6: to write one word.
- 16: to write n words (maximum 128).

N.B.:

1 word \Leftrightarrow 2 bytes \Leftrightarrow 16 bits

2 words \Leftrightarrow 4 bytes \Leftrightarrow 32 bits

The broadcast communication is available for the log that stores the tariff.

8.4. Communication tables

The communication tables and relevant notes are available online on the COUNTIS E03/E04 documentation page at:

www.socomec.com/en/countis-e0x



9. CONFIGURATION

The device can be configured directly from the COUNTIS E03/E04 screen in programming mode or via the communication link. The paragraphs below describe configuring using the screen.

9.1. On-screen configuration

From the screen, go to programming mode to change your communication settings. How to browse through the programming mode is described in the following stages:

| Function | Where | Buttons | Press |
|---|---------------------------------|---------|-----------|
| Switch pages within a menu | Every page within a menu | ● | Realtime |
| Go to SETUP menu | Menu page SETUP | | > 3 sec |
| Change a value/digit | SETUP pages | | real-time |
| Confirm a value/digit | SETUP pages | | > 3 sec |
| Exit SETUP menu | SAVE screen from the SETUP menu | | > 3 sec |
| Start/stop the displayed partial meter | Partial meter menu | | > 3 sec |
| Reset the displayed partial meter to zero | Partial meter menu | | > 3 sec |

9.1.1. View all of the menu "SETUP"

In the SETUP menu, press "●" for 3 seconds to put the device into programming mode.

Press "●" to go to the different screens:

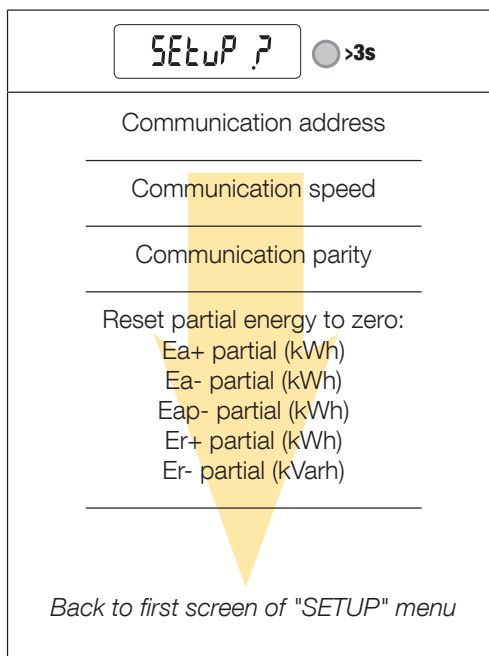

9.1.2. Detailed view of menu "SETUP"

| | |
|------------------------------|--|
| SETUP ? ● >3s | |
| Communication address | |
| Addr005 | 1, 2, ... 5 , ..., 246, 247 |
| Communication speed | |
| bAu 384k | 2400, 4800, 9600, 19200, 38400 |
| Communication parity | |
| Prty n | n = no o = odd E = even |
| Reset energy | |
| rES ALL | Ea+ partial; Ea- partial; Eap partial; Er+ partial; Er- partial |

Back to first screen of "SETUP" menu



9.1.3. Example: setting the communication address

In "SETUP" mode (see page 14), go to the "Addr communication address" screen

Example: changing the communication address to 247.

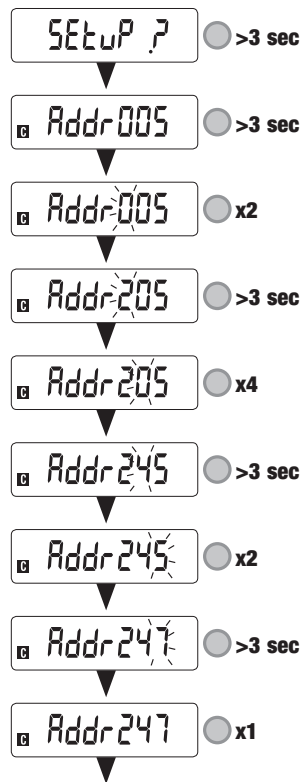

Communication speed
Communication parity
Reset partial energy to
zero

XX = default value

10. USE

The electric measurements or information is/are accessible by pressing the "●" button once.

The associated measurements are described in the table below:

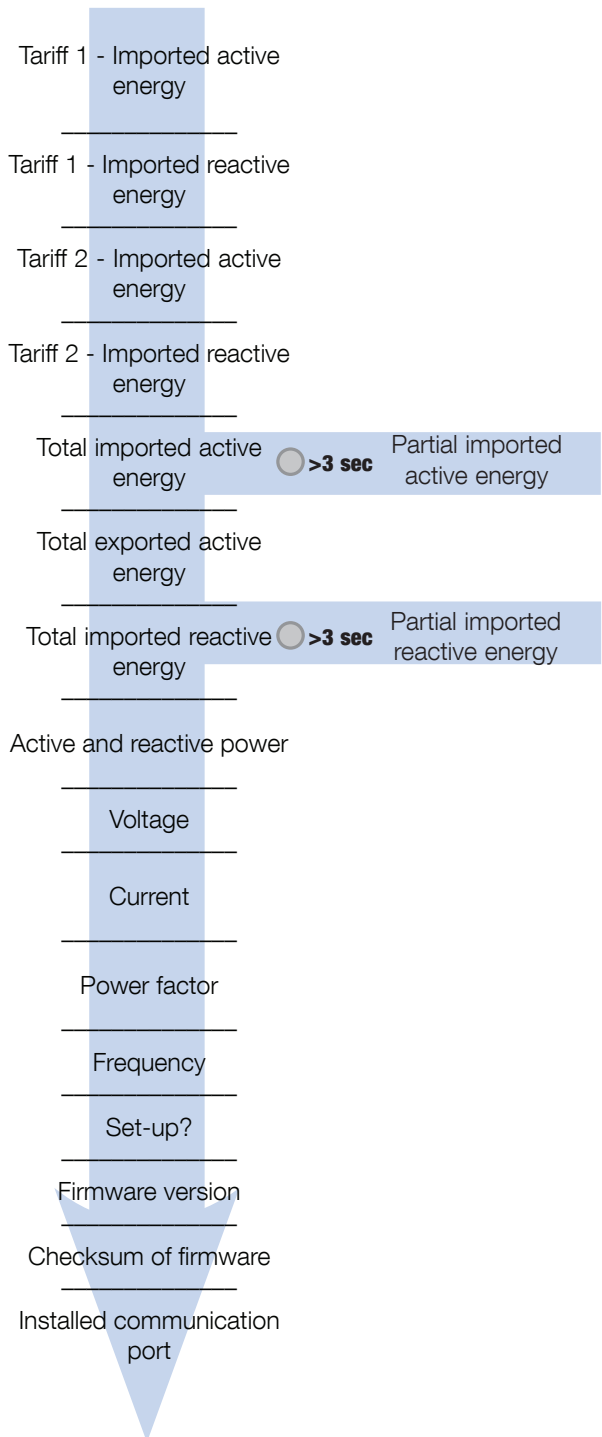

10.1. Detailed view of the Main menu

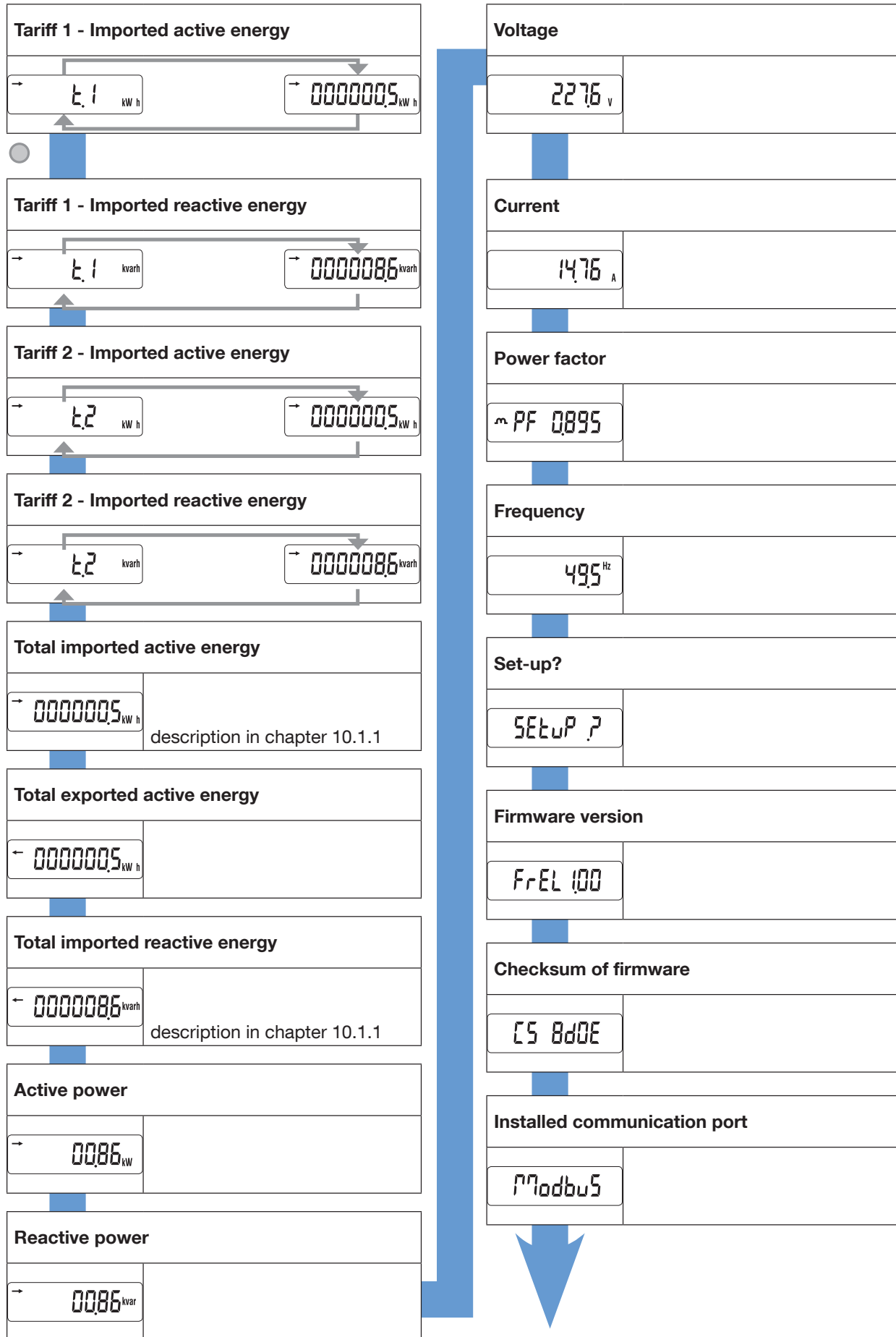

10.1.1. Detailed view of the partial energy meter

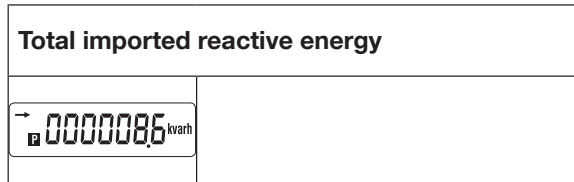
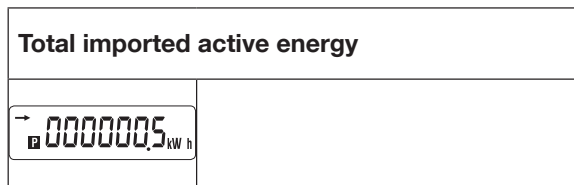

10.1.2. Starting up the partial energy meter

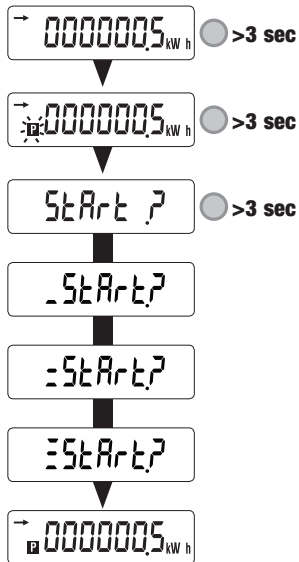

10.1.3. Stopping the partial energy meter

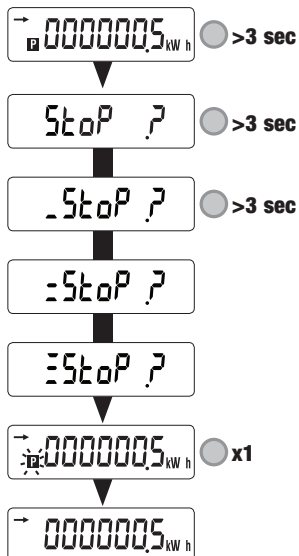

10.1.4. Resetting the partial energy meter to zero

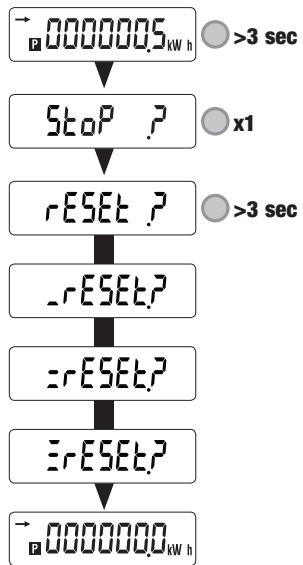

11. DIAGNOSTICS MESSAGES

The following message appears if there are connection or malfunction errors.

11.1. Malfunction



- When messages with the code xx are displayed, the meter has malfunctioned and must be replaced.

12. ASSISTANCE

| Causes | Solutions |
|--------------------|---|
| Device not working | Check the neutral and phase cable connections |
| Error message | Check the meter is working OK |

13. CHARACTERISTICS

| GENERAL FEATURES | |
|-------------------------------------|---|
| Compliant with | European EMC Directive No. 2014/30/EU dated 26/02/2014 LV Directive No. 2014/35/EU dated 26/02/2014 Measuring Instrument Directive MID No. 2014/32/EU dated 26/02/2014 EN50470-1/-3 IEC 62053-21/-23 |
| Frequency | 45 and 65 Hz |
| Power supply | Self-supplied |
| Rated dissipated power (Wmax.) | 1.5 VA - 1 W |
| FEATURES | |
| Single-phase connectivity | 2 wires 230 V |
| Stores energy readings and settings | In the EEPROM memory |
| Identifies display of tariffs | T1 and T2 |
| CURRENT MEASUREMENTS | |
| Type | Single-phase - direct 40 A |
| Input consumption | 0.5 VA |
| Start-up current (Ist) | 20 A |
| Minimum current (Imin) | 0.25 A |
| Transition current (Itr) | 0.5 A |
| Reference current (Iref) | 5 A |
| Permanent overload (Imax) | 40 A |
| Intermittent overload | 30 Imax for 1/2 cycle |
| OVERLOAD CAPACITY | |
| DC voltage Un | 276 VAC |
| Realtime voltage Un (1 s) | 300 VAC |
| DC current Imax | 40 A |
| Realtime current Imax | 30 Imax for 1/2 cycle |
| VOLTAGE MEASUREMENTS | |
| Range of measurement | 230 ± 20% |
| Power consumption | 7.5 VA max |
| Permanent overload | 280 V phase-neutral |
| FREQUENCY MEASUREMENT | |
| Frequency measurement | 45-65 Hz |
| ENERGY MEASUREMENT | |
| Active | Yes |
| Reactive | Yes |
| Total and partial reading | Yes |
| MID metering | Bidirectional with single-phase |
| Resolution | 10 Wh, 10 varh |
| ENERGY ACCURACY | |
| Active energy Ea+ | Class B (EN 50470-3) E04 Class 1 (EN 62053-21) |
| Reactive energy Er+ | Class 2 (EN 62053-23) |
| TARIFF for Ea+ | |
| Tariff management | Yes (via communication) |

| | |
|---|---|
| Number of tariffs managed | 2 |
| Tariff input | No |
| METROLOGICAL LED (Ea+) | |
| Pulse value | 5,000 pulses / kWh |
| Colour | Red |
| PULSE OUTPUT | |
| Type | Opto-isolated - 5 ... 27 VDC 27 mA according to EN 62053-31 |
| Pulse weight | 100 Wh |
| DISPLAY | |
| Type | 7-digit LCD with backlight |
| Refresh time | 0.5 s |
| Backlight activation time | 10 s |
| Active energy: 1 display, 7-digit | 000000.0 - 999999.9 kWh |
| Reactive energy: 1 display, 7-digit | 000000.0 - 999999.9 kvarh |
| Realtime active power: 1 display, 4-digit | 00.00 - 99.99 kW |
| Realtime reactive power: 1 display, 4-digit | 00.00 - 99.99 kvar |
| Realtime voltage: 1 display, 4-digit | 000.0 ... 999.9 V |
| Realtime current: 1 display, 4-digit | 00.00 ... 99.99 A |
| Power factor: 1 display, 4-digit | 0.001-1.000 |
| Frequency: 1 display, 4-digit | 45.00-65.00 Hz |
| COMMUNICATION | |
| RS485 | 2 wires + shielding/ half duplex |
| Protocol | Modbus, RTU mode |
| Baud rate | 2400 / 4800 / 9600 / 19200 / 38400 bps |
| Insulation | SELV |
| Load unit | 1/8 |
| SAVING | |
| Energy registers | In the EEPROM memory |
| ENVIRONMENTAL CONDITIONS | |
| Mechanical environment | M1 |
| Electromagnetic environment | E2 |
| Operating temperature range | -25°C to +55°C |
| Storage temperature | -25°C to 75°C |
| Humidity | ≤ 80% |
| Installation | Internal (box/cabinet) |
| Vibrations | ±0.075 mm |
| HOUSING | |
| Dimensions W x H x D (mm) | Modular - width of 1 module (DIN 43880) 18 x 90 x 70 |
| Installation | On DIN rail (EN 60715) |
| Connection capacity, tightening torque | See chapter "6. Connection", page 10 |
| Protection index | Front: IP51 - casing: IP20 |
| Insulation class | Class II (EN 50470-1) |
| Weight | 100 g |

GLOSSARY OF ABBREVIATIONS

| | |
|---------|--|
| GB | Metrological firmware version |
| CS | Checksum of metrological firmware |
| t.1 | Tariff 1 |
| t.1 | Tariff 2 |
| Set-up? | Set-up menu |
| Addr | Slave address |
| bAu | Communication speed in bauds (bits per second) |
| Prty | Communication frame parity |
| n | No parity |
| o | Off parity |
| E | Even parity |
| RESALL | Reset all partial energies |
| SAVE? | Confirm selection |
| Y | Save and exit |
| N | Exit without saving |
| C | Continue without saving |

CORPORATE HQ CONTACT:
SOCOMECSAS
1-4 RUE DE WESTHOUSE
67235 BENFELD, FRANCE

www.socomec.com



545 865 A - EN - 02/17

 **socomec**
Innovative Power Solutions