



Выключатели нагрузки для гелиоэнергетики Socomes Sirco MV PV (63-160 A) - руководство пользователя. Юниджет

Постоянная ссылка на страницу: <https://www.uni-jet.com/catalog/commutation/vyiklyuchateli-nagruzki/socomes-sirco-mv-pv/>



GB Assembly and wiring of SIRCO MV PV.
F Montage et câblage des SIRCO MV PV.
E Montaje y conexión de los SIRCO MV PV.

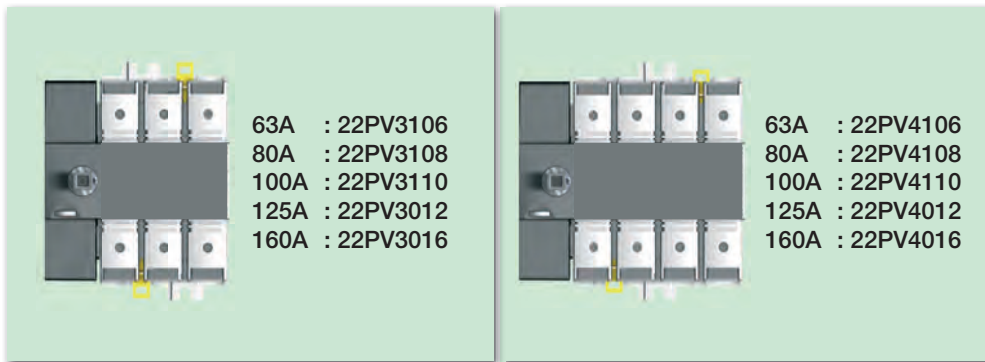

63A : 22PV3106
 80A : 22PV3108
 100A : 22PV3110
 125A : 22PV3012
 160A : 22PV3016

63A : 22PV4106
 80A : 22PV4108
 100A : 22PV4110
 125A : 22PV4012
 160A : 22PV4016

Connection / Raccordement / Conexión

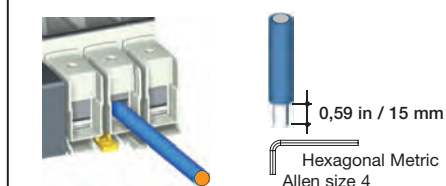

Wire / Câble / Cable	Torque / Couple / Par de apriete
6 mm ² - 50 mm ² stranded	35.4 lb-in / 4 Nm
10 to 1 AWG stranded	35.4 lb-in / 4 Nm
1/0 AWG stranded	39.8 lb-in / 4,5 Nm
2/0 AWG stranded	44.3 lb-in / 5 Nm
2/0 AWG compact stranded	48.7 lb-in / 5,5 Nm

Wire / Câble / Cable	Torque / Couple / Par de apriete
10 mm ² - 70 mm ² solid	35.4 lb-in / 4 Nm
# 12 to # 10 AWG solid	35.4 lb-in / 4 Nm

Dual dimensions in/mm
 Double dimensions in/mm
 Doble dimensiones in/mm



Wire / Câble / Cable	Torque / Couple / Par de apriete
0,5 mm ² - 1 mm ² stranded	3.97 lb-in / 0,45 Nm
# 20 to # 18 AWG stranded	3.97 lb-in / 0,45 Nm

Wire / Câble / Cable	Torque / Couple / Par de apriete
0,5 mm ² - 1,5 mm ² solid	3.97 lb-in / 0,45 Nm
# 20 to # 16 AWG solid	3.97 lb-in / 0,45 Nm

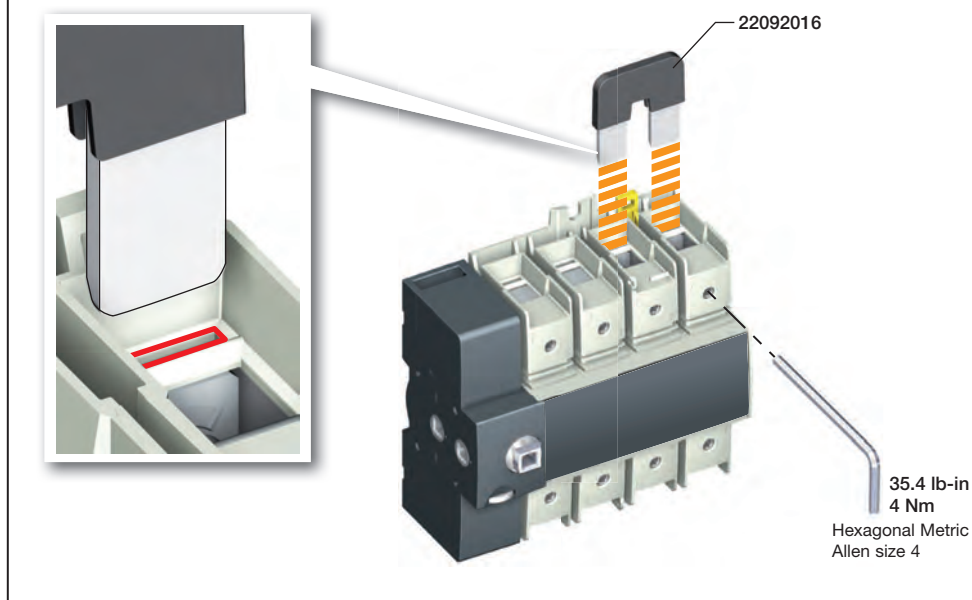

POLE CONNECTION IN SERIES CONFIGURATION RACCORDEMENT CONEXIÓN DE LOS POLOS EN SERIES

OBLIGATORY **OBLIGATOIRE** **OBLIGATORIO**

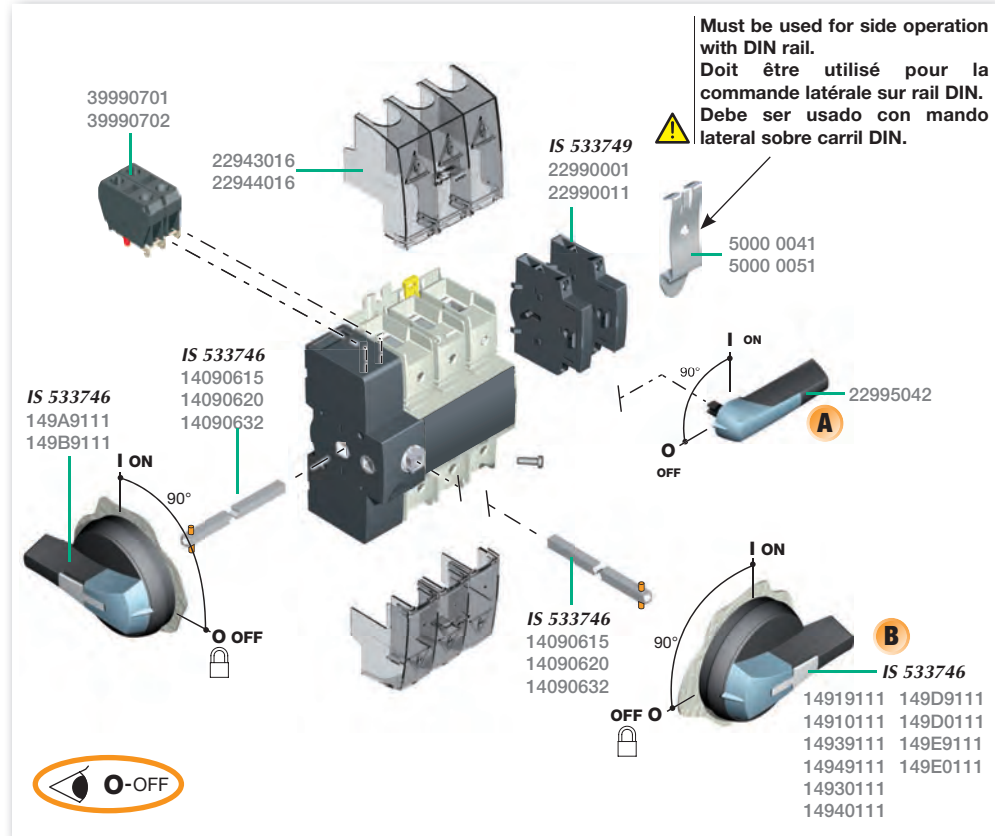
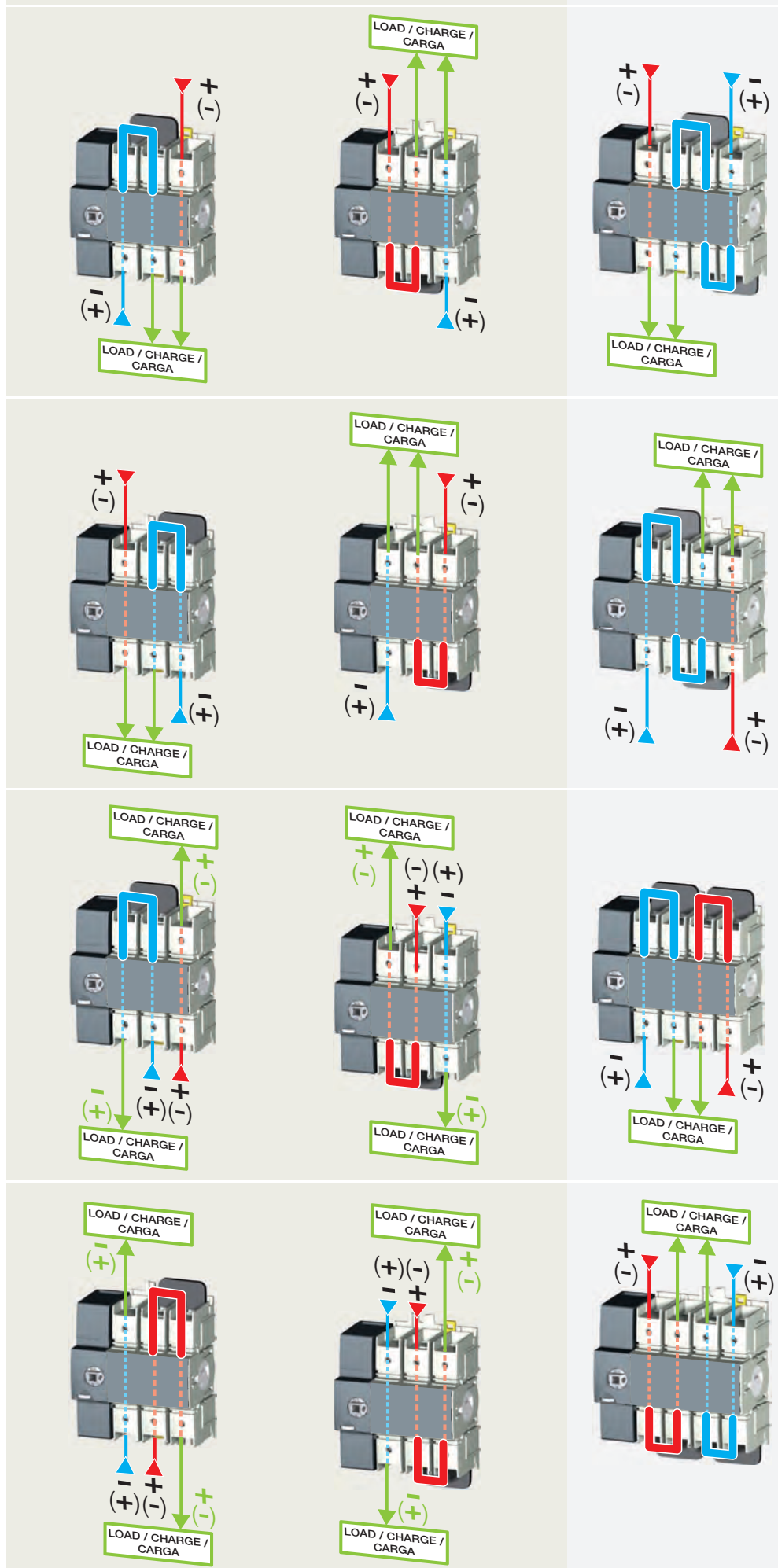

Edition 03/2010 - RECTO-VERSO / S blanc offset 80g/m² / QUADRI / F 297x420 / P 2 PLI ROULES - 1 PLI CROISE

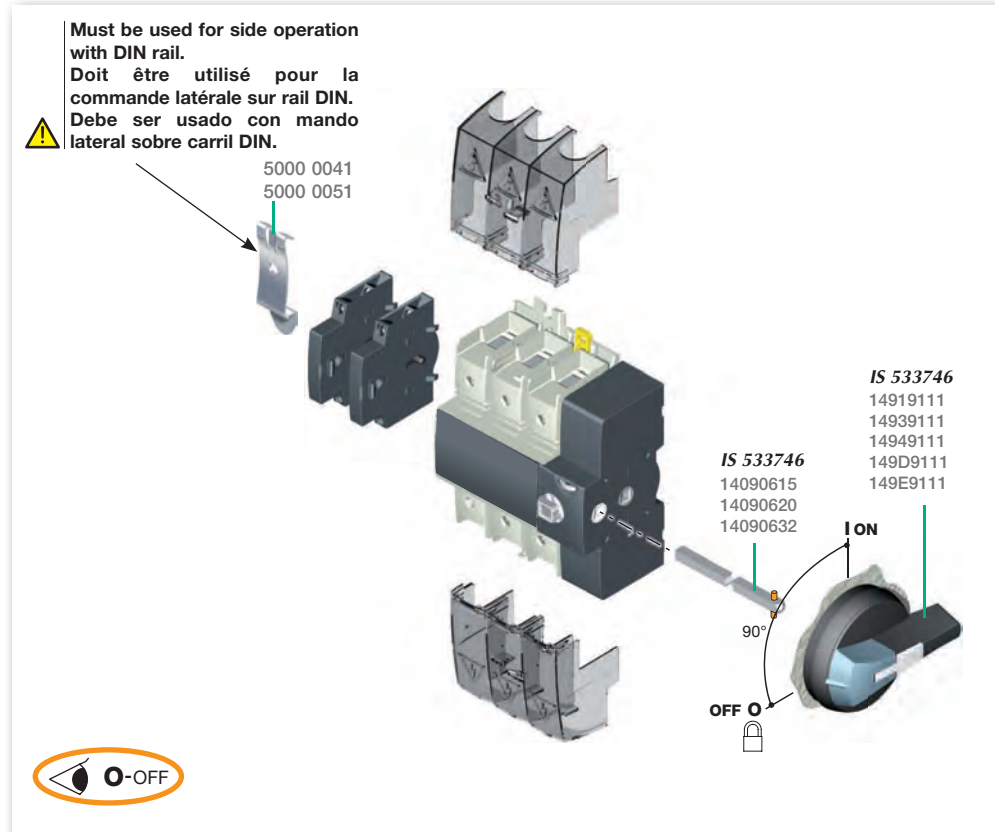

Terminal shrouds mounting / Montage cache-bornes / Montaje cubrebornes

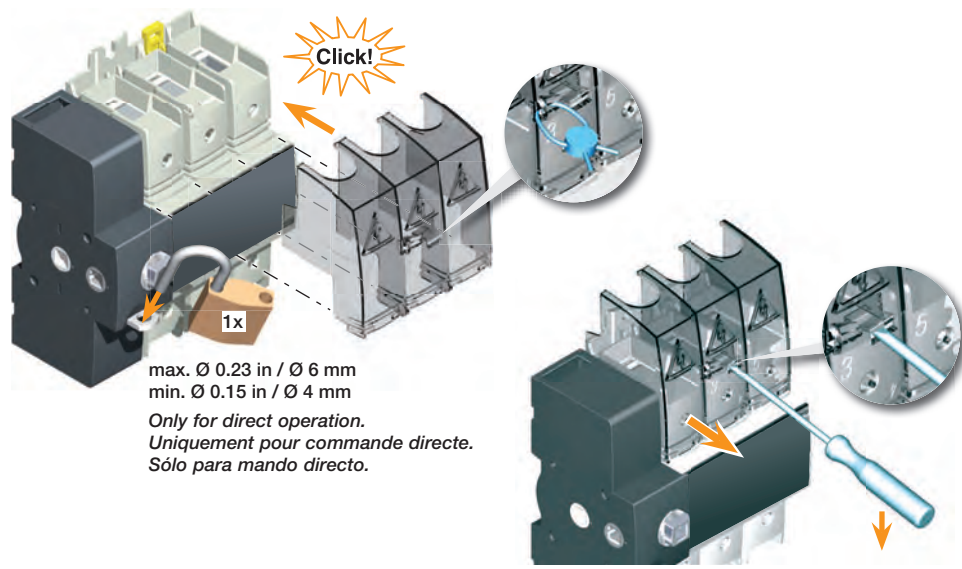

Rail mounting / Montage sur rail DIN / Montaje sobre carril DIN

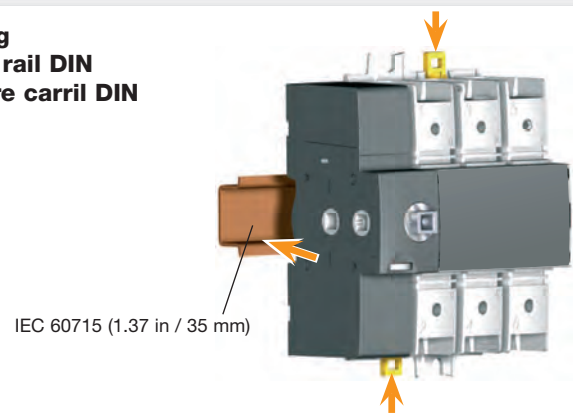

Direct and front operation / Commande directe et frontale / Mando directo y frontal

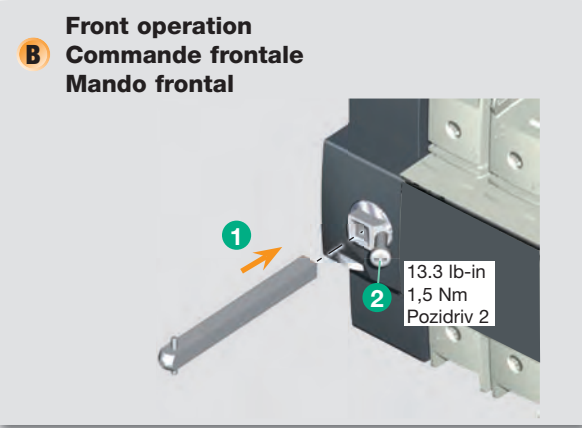
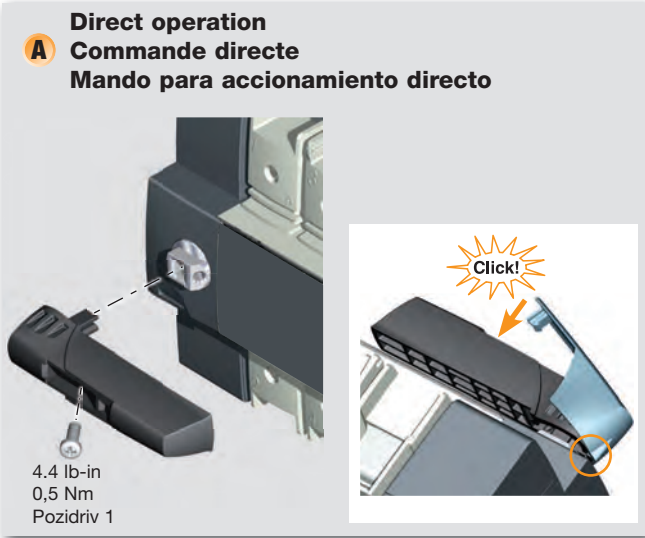

Aux. Contacts U type / Contacts aux. type U / Contactos auxiliares tipo U

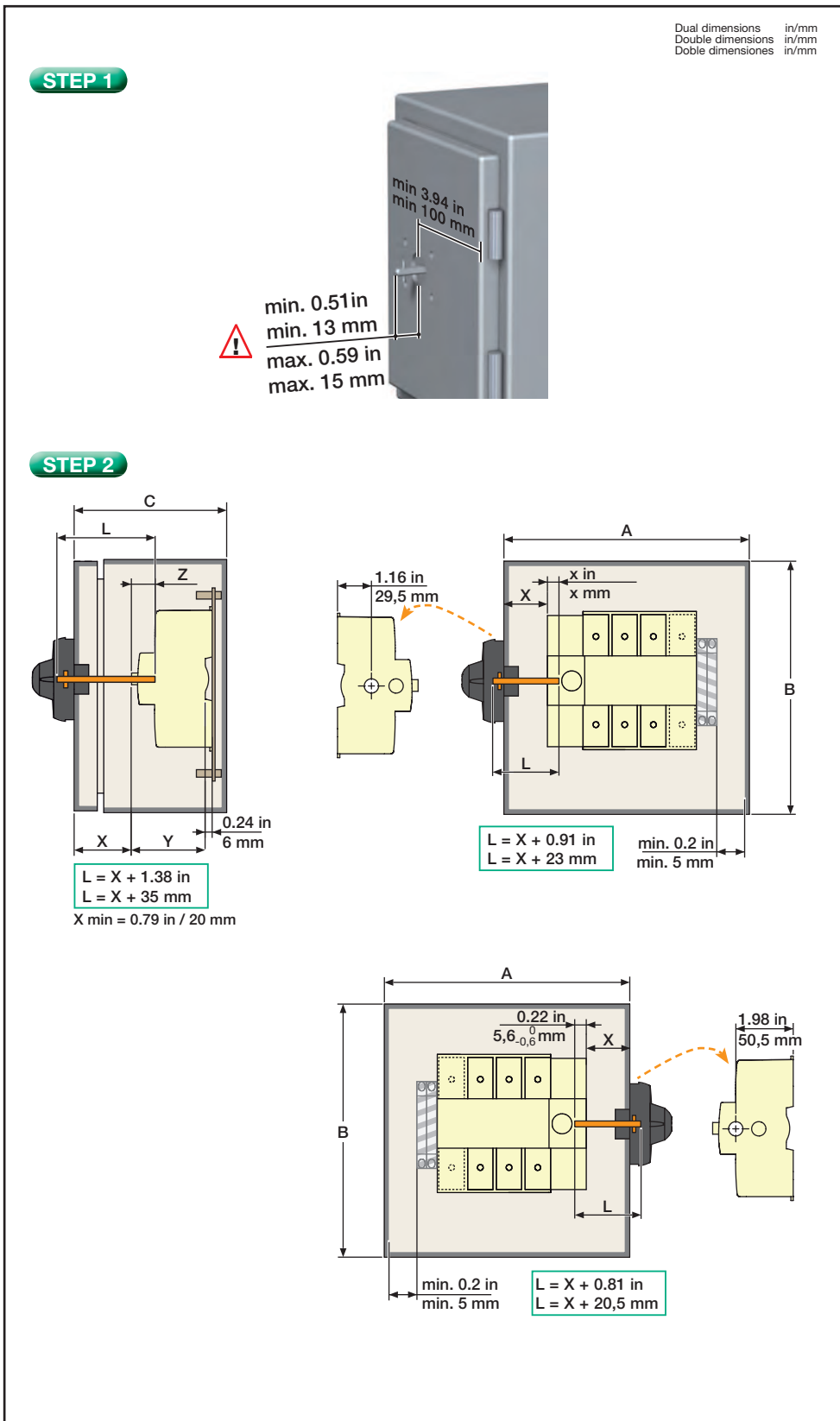
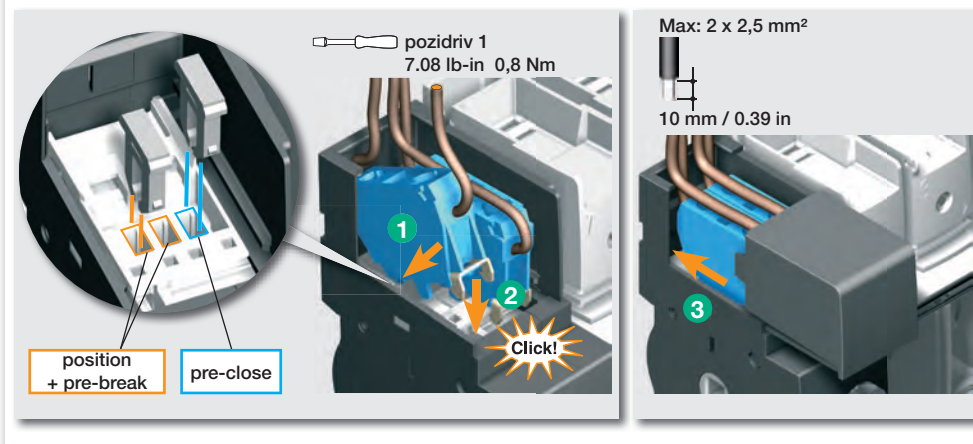

Aux. Contacts M type / Contacts aux. type M / Contactos auxiliares tipo M

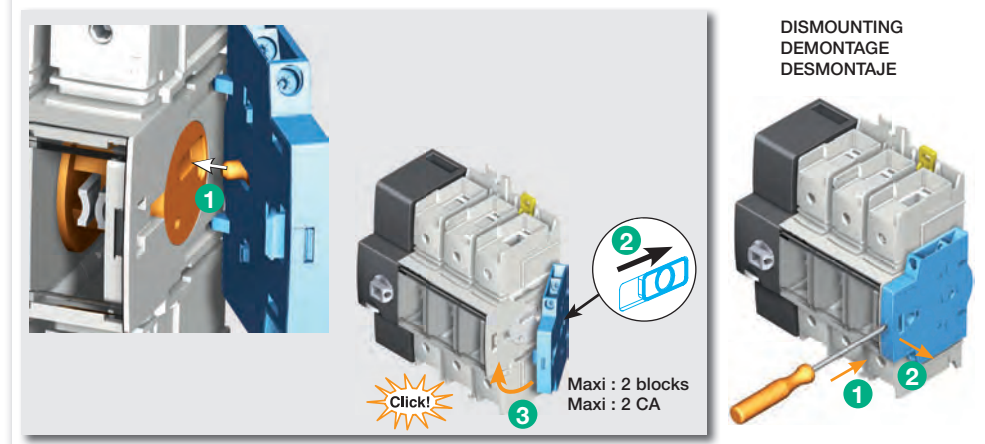

Switch / Interrupteur / Interruptor

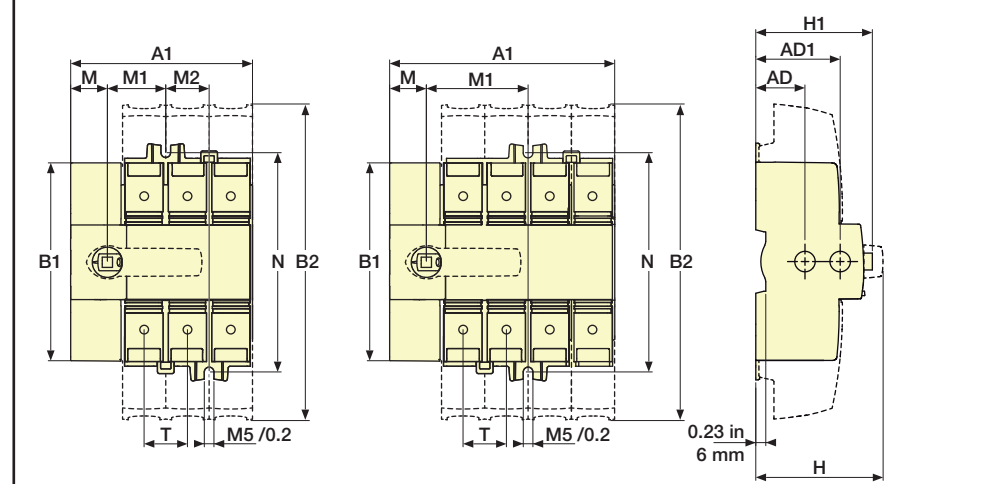

Aux. Contacts M type / Contacts aux. type M / Contactos auxiliares tipo M

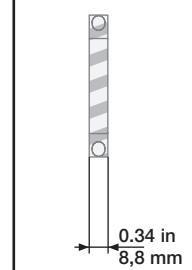

	3P		4P	
	in	mm	in	mm
A	6.41	163	7.44	189
B	10.2	259	10.2	259
C	4.52	115	4.52	115
A1	4.29	109	5.31	135
AD	1.16	29,5	1.16	29,5
AD1	1.98	50,5	1.98	50,5
B1	4.90	124,5	4.90	124,5
B2	7.44	189	7.44	189
H	3.30	84	3.30	84
H1	2.75	70	2.75	70
M	0.86	22	0.86	22
M1	1.37	35	2.40	61
M2	1.02	26	/	/
N	5.19	132	5.19	132
T	1.02	26	1.02	26
Y	2.52	64	2.52	64
Z min.	0.63	16	0.63	16
Z max.	0.83	21	0.83	21

⚠ DANGER / DANGER / PELIGRO

HAZARDOUS VOLTAGE. This equipment must be installed and serviced only by qualified electrical personnel. Turn off all power supplying this equipment before working on or inside equipment. Always use a properly rated voltage sensing device to confirm power is off. Replace all devices, doors, and covers before turning on power to this equipment. **Failure to follow these instructions will result in death or serious injury.**

TENSION DANGEREUSE. L'installation et l'entretien de cet appareil ne doivent être effectués que par du personnel qualifié. Coupez l'alimentation de cet appareil avant d'y travailler. Utilisez toujours un dispositif de détection de tension à valeur nominale approprié pour confirmer que toute alimentation est coupée. Remplacez tous les dispositifs, les portes et les couvercles avant de mettre cet appareil sous tension. **Si ces précautions ne sont pas respectées, cela entraînera la mort ou des blessures graves.**

TENSION PELIGROSA. Solamente el personal de mantenimiento eléctrico especializado deberá instalar y prestar servicios de mantenimiento a este equipo. Desenergice el equipo antes de realizar cualquier trabajo en él. Siempre utilice un dispositivo detector de tensión adecuado para confirmar la desenergización del equipo. Vuelva a colocar todos los dispositivos, las puertas y las cubiertas antes de energizar este equipo. **El incumplimiento de estas precauciones podrá causar la muerte o lesiones serias.**