



**Выключатель нагрузки для энергораспределения Socomec Sirco AC (630-1600 A) -
руководство пользователя. Юниджет**

Постоянная ссылка на страницу: <https://www.uni-jet.com/catalog/sistemyi-kommutaczii,-kontrolya-i-zashhityi/vyiklyuchateli-nagruzki/socomec-sirco-ac.html>



- GB** Assembly and wiring of SIRCO AC.
- F** Montage et câblage des SIRCO AC.
- E** Montaje y conexión de los SIRCO AC.

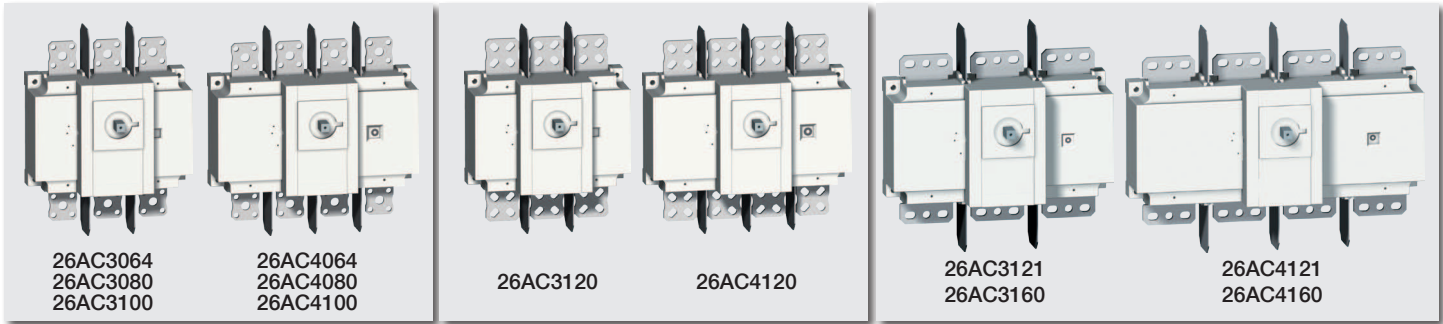

Switch and accessories
L'interrupteur et ses accessoires
El interruptor y sus accesorios

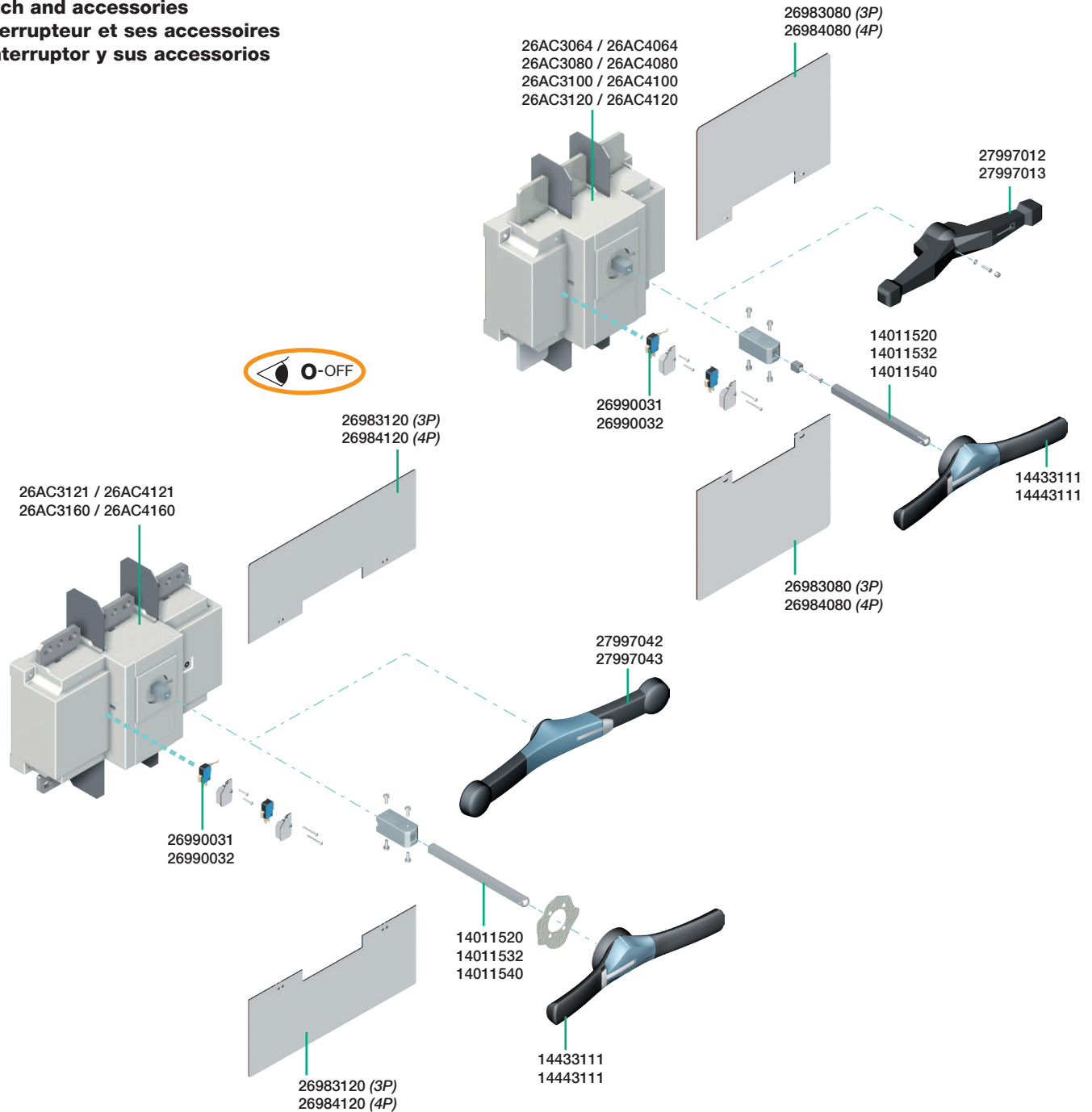

⚠ DANGER / DANGER / PELIGRO

HAZARDOUS VOLTAGE . This equipment must be installed and serviced only by qualified electrical personnel. Turn off all power supplying this equipment before working on or inside equipment. Always use a properly rated voltage sensing device to confirm power is off. Replace all devices, doors, and covers before turning on power to this equipment. **Failure to follow these instructions will result in death or serious injury.**

TENSION DANGEREUSE. L'installation et l'entretien de cet appareil ne doivent être effectués que par du personnel qualifié. Coupez l'alimentation de cet appareil avant d'y travailler. Utilisez toujours un dispositif de détection de tension à valeur nominale approprié pour confirmer que toute alimentation est coupée. Remplacez tous les dispositifs, les portes et les couvercles avant de mettre cet appareil sous tension. **Si ces précautions ne sont pas respectées, cela entraînera la mort ou des blessures graves.**

TENSION PELIGROSA. Solamente el personal de mantenimiento eléctrico especializado deberá instalar y prestar servicios de mantenimiento a este equipo. Desenergice el equipo antes de realizar cualquier trabajo en él. Siempre utilice un dispositivo detector de tensión adecuado para confirmar la desenergización del equipo. Vuelva a colocar todos los dispositivos, las puertas y las cubiertas antes de energizar este equipo. **El incumplimiento de estas precauciones podrá causar la muerte o lesiones serias.**

Edition 12/12 - RECTO-VERSO / S blanc offset 80g/m² / QUADRI

- 1 26AC3064
- 2 26AC4064
- 3 26AC3080
- 4 26AC4080
- 5 26AC3100
- 6 26AC4100
- 7 26AC3120
- 8 26AC4120
- 9 26AC3121
- 10 26AC4121
- 11 26AC3160
- 12 26AC4160

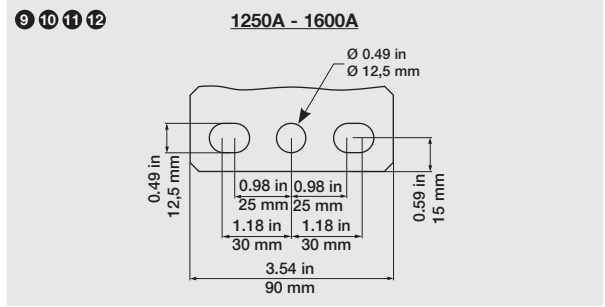
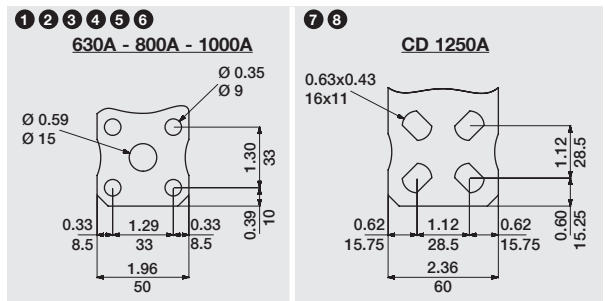
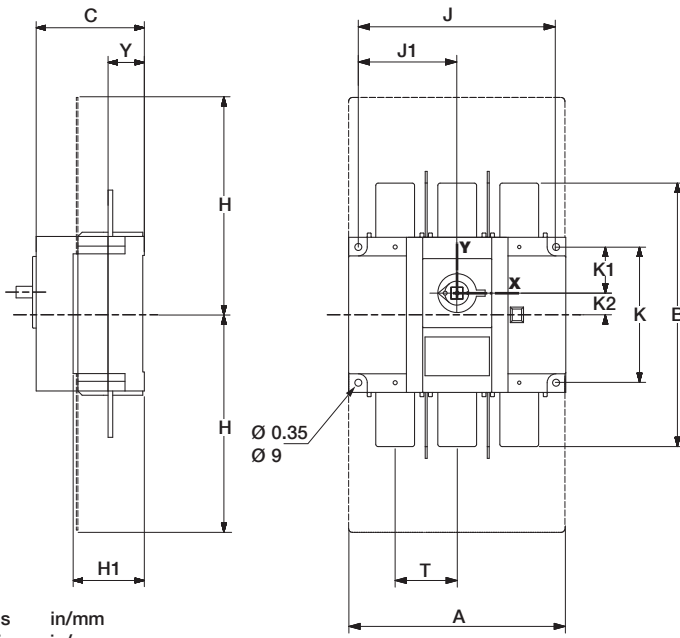

Dual dimensions in/mm
 Double dimensions in/mm
 Doble dimensiones in/mm

		A		B		C		H		H1		J		J1		K		K1		K2		T		Y	
		in	mm	in	mm	in	mm	in	mm	in	mm	in	mm	in	mm	in	mm	in	mm	in	mm	in	mm	in	mm
1 3 5	3P	11.02	280	12.63	321	5.47	139	9.05	230	4.05	103	10.04	255	5	127.5	6.88	175	2.34	59.5	1.10	28	3.15	80	1.83	46.5
2 4 6	4P	14.17	360									13.19	335	6.59	167.5										
7	3P	11.02	280	12.99	330	5.47	139	9.05	230	4.05	103	10.04	255	5	127.5	6.88	175	2.34	59.5	1.10	28	3.15	80	1.83	46.5
8	4P	14.17	360									13.19	335	6.59	167.5										
9 11	3P	14.65	372	11.34	288	5.47	139	9.05	230	4.05	103	13.66	347	6.83	173.5	6.88	175	2.34	59.5	1.1	28	4.72	120	1.87	47.5
10 12	4P	19.37	492									18.39	467	9.19	233.5										

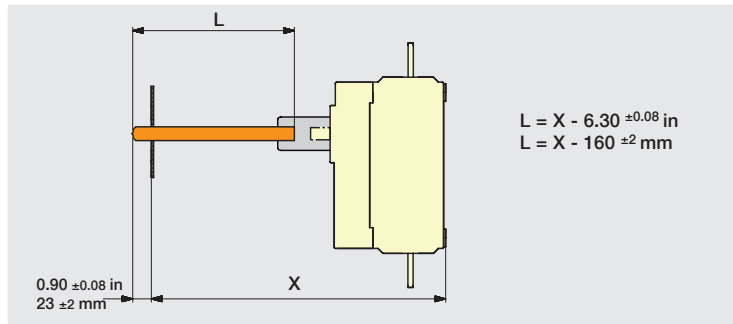

Mounting orientation / Sens de montage / Sentido de montaje

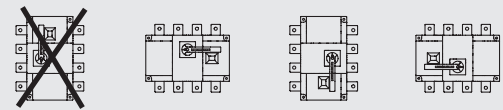

Mounting of terminal covers
 Montage des capots
 Montaje de los Cubrebornes

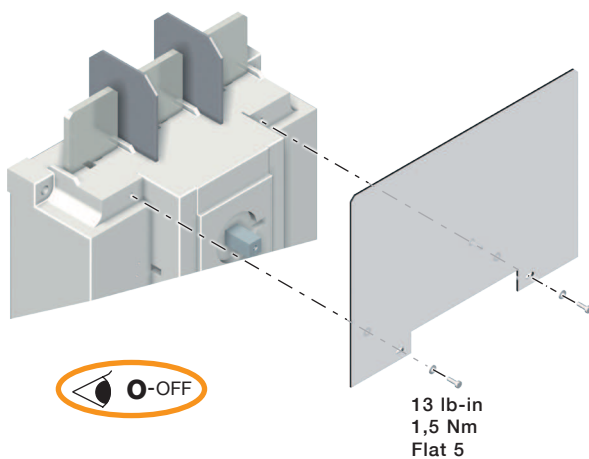

Mounting of auxiliary contacts
 Montage des contacts auxiliaires
 Montaje de los contactos auxiliares

