



**uni jet**

**ИБП Liebert NX (225-600 кВА) - руководство по эксплуатации. Юниджет**

Постоянная ссылка на страницу: <https://www.uni-jet.com/catalog/ibp/online-ibp/liebert-nx/>





# Liebert® NX™ UPS

Operation and Maintenance Manual — 225-600kVA, Three-Phase, Single-Module & Multi-Module

---

## CONTACTING VERTIV FOR SUPPORT

---

To contact Vertiv Liebert® Services for information or repair service in the United States, call 800-543-2378. Liebert Services offers a complete range of start-up services, repair services, preventive maintenance plans and service contracts.

For repair or maintenance service outside the 48 contiguous United States, contact Liebert Services, if available in your area. For areas not covered by Liebert Services, the authorized distributor is responsible for providing qualified, factory-authorized service.

For Liebert Services to assist you promptly, please have the following information available:

Part numbers: \_\_\_\_\_

Serial numbers: \_\_\_\_\_

Rating: \_\_\_\_\_

Date purchased: \_\_\_\_\_

Date installed: \_\_\_\_\_

Location: \_\_\_\_\_

Input voltage/frequency: \_\_\_\_\_

Output voltage/frequency: \_\_\_\_\_

DC source reserve time: \_\_\_\_\_

### Product Warranty Registration

To register for warranty protection, visit the Service and Support section of our Web site at:

[www.liebert.com](http://www.liebert.com)

Click on Product Registration and fill out the form.

©2016 Vertiv Co. All rights reserved throughout the world.

This document may contain confidential and/or proprietary information of Liebert Corporation, and its receipt or possession does not convey any right to reproduce, disclose its contents, or to manufacture or sell anything that it may describe. Reproduction, disclosure, or use without specific authorization from Liebert Corporation is strictly prohibited.

---

---

# TABLE OF CONTENTS

<b>IMPORTANT SAFETY INSTRUCTIONS</b> .....	<b>1</b>
<b>SAVE THESE INSTRUCTIONS</b> .....	<b>1</b>
<b>1.0 INTRODUCTION</b> .....	<b>3</b>
1.1 General Description .....	3
1.2 Modes of Operation .....	4
1.2.1 Normal Mode .....	4
1.2.2 Eco Mode .....	4
1.2.3 Bypass Mode .....	4
1.2.4 Battery Mode .....	4
1.2.5 Maintenance Bypass .....	4
1.3 Options .....	5
<b>2.0 OPERATION</b> .....	<b>6</b>
2.1 Physical Layout of the UPS .....	6
2.2 Interface Display Features .....	8
2.3 Touchscreen Navigation .....	10
2.3.1 Main Display Screen .....	10
2.3.2 Status .....	11
2.3.3 Events Log Menu .....	16
2.3.4 Measures Menu .....	16
2.3.5 Battery Menu .....	20
2.3.6 LIFE™ Menu .....	22
2.3.7 Settings Menu .....	23
2.4 Animated One-Line Mimic .....	24
2.4.1 Functional Blocks .....	24
2.4.2 About Menu .....	24
2.5 Modes of Operation .....	25
2.5.1 Load on Bypass .....	25
2.5.2 Normal Mode—Load on UPS .....	27
2.5.3 Input Power Failure—Load on DC Source .....	27
2.5.4 Off DC Source .....	28
2.5.5 Remote Emergency Power Off .....	28
2.6 Eco Mode Active .....	29
2.6.1 Eco Mode Activation and Control .....	29
2.6.2 Active Eco Mode .....	29
2.6.3 Normal—Active Eco Mode .....	29
2.6.4 Inverter Stop—Active Eco Mode .....	30
2.6.5 Overload—Active Eco Mode .....	30
2.6.6 Emergency—Due to Source Supply Failure or Variance Beyond Tolerance Limits, Active Eco Mode .....	30
2.6.7 Return to Normal Conditions-Active Eco Mode .....	30

---

2.7	Manual Operations—All Systems .....	30
2.7.1	Startup—Single Module System .....	34
2.7.2	Startup Single Module System from Maintenance Bypass .....	35
2.7.3	Load Transfer and Retransfer—Single Module System .....	37
2.7.4	Maintenance Bypass Load Transfers—Single Module System .....	37
2.7.5	Shut Down Single Module UPS System .....	38
2.7.6	Startup—1+N Multi-Module System with Maintenance Bypass Cabinet .....	39
2.7.7	Transfer the Load from UPS to Bypass: 1+N System .....	40
2.7.8	Transfer Load from Bypass to UPS: 1+N Distributed Bypass System .....	40
2.7.9	Load Transfer-1+N System—Remove One UPS Module from System (Collective) .....	41
2.7.10	Load Transfer-1+N System—Add One UPS Module to the System (Collective) .....	41
2.7.11	De-Energize 1+N System With Maintenance Bypass Cabinet .....	41
2.8	Automatic Operations .....	42
2.8.1	Overloads (Without Transfer) .....	42
2.8.2	Automatic Transfers to Bypass (Overload Condition) .....	43
2.8.3	Automatic Transfers to Bypass, UPS System Faults .....	43
2.8.4	Automatic Retransfers to UPS .....	44
<b>3.0</b>	<b>UPS MESSAGES: STATUS, WARNING, FAULT .....</b>	<b>45</b>
<b>4.0</b>	<b>CONNECTIVITY .....</b>	<b>54</b>
4.1	Network and BMS Connectivity and Monitoring .....	54
4.1.1	Determining the type of Card in Your System .....	54
4.2	Connection Points .....	54
4.2.1	Available Selectable Input Contacts .....	55
4.2.2	Available Selectable Output Contacts .....	56
<b>5.0</b>	<b>MAINTENANCE .....</b>	<b>57</b>
5.1	Safety Precautions .....	57
5.2	Vertiv Liebert Services .....	57
5.3	Routine Maintenance .....	58
5.3.1	Record Log .....	58
5.3.2	Air Filters .....	58
5.3.3	Limited Life Components .....	59
5.4	Battery Maintenance .....	60
5.4.1	Battery Safety Precautions .....	60
5.5	Detecting Trouble .....	63
5.5.1	Items to check include: .....	63
5.6	Reporting a Problem .....	63
5.7	Upstream Feeder Circuit Breaker Setting Inspections .....	63
5.8	AC Output Ground Fault Detection .....	64
<b>6.0</b>	<b>SPECIFICATIONS .....</b>	<b>65</b>
6.1	DC Sources .....	65
6.1.1	Battery Operation .....	65
6.2	Other DC Sources .....	65
6.3	Battery DC Ground Fault Detection .....	65
6.4	Environmental Conditions .....	66

---

---

6.5	Thermal Runaway Protection.....	66
-----	---------------------------------	----

<b>APPENDIX A - SYSTEM CONFIGURATION .....</b>	<b>A68</b>
--	------------

## FIGURES

Figure 1	Typical single module UPS system one-line diagram.....	3
Figure 2	Main component locations—225-300kVA Liebert NX.....	6
Figure 3	Main component details—225 to 300kVA Liebert NX.....	7
Figure 4	Main component details, 400-600kVA Liebert NX .....	8
Figure 5	Main display screen, typical .....	9
Figure 6	Normal Mode .....	9
Figure 7	Utility fail .....	10
Figure 8	Load on bypass .....	10
Figure 9	Main display screen, MBD open.....	12
Figure 10	Load status .....	12
Figure 11	Rectifier status.....	13
Figure 12	Bypass status.....	13
Figure 13	Inverter status .....	14
Figure 14	Charger/Booster status.....	14
Figure 15	Battery status.....	15
Figure 16	Status summary.....	16
Figure 17	Rectifier measures .....	17
Figure 18	Bypass measures .....	17
Figure 19	Inverter measures.....	18
Figure 20	Charger/Booster measures .....	18
Figure 21	Battery measures .....	19
Figure 22	Load measures.....	19
Figure 23	Battery parameters.....	21
Figure 24	LIFE menu .....	22
Figure 25	Settings Menus .....	23
Figure 26	About menu .....	24
Figure 27	Load on bypass, UPS not operating.....	25
Figure 28	Load on bypass, UPS available.....	26
Figure 29	Eco Mode one-line mimic display .....	26
Figure 30	Load on UPS, bypass available.....	27
Figure 31	Input power failure, load on DC source .....	27
Figure 32	Load on UPS, DC source not available.....	28
Figure 33	Remote Emergency Power Off .....	28
Figure 34	Maintenance bypass configurations—Two breaker .....	31
Figure 35	Maintenance bypass configurations—Three breaker for single-input UPS .....	31
Figure 36	Maintenance bypass configurations—Three breaker for dual-input UPS .....	31
Figure 37	Maintenance bypass configurations—Four breaker for dual-input UPS .....	32
Figure 38	Maintenance bypass configurations—Four breaker for dual-input UPS, No CB1.....	32
Figure 39	Maintenance bypass configurations—Distributed bypass, 1+N multi-module .....	33
Figure 40	Two-module 1+N UPS system, single input, common battery and paralleling switchboard .....	68

---

## TABLES

Table 1	Measurements for functional blocks .....	16
Table 2	Functional block information .....	24
Table 3	Current-versus-time curves of overload capacity .....	43
Table 4	UPS status, warning and fault messages .....	45
Table 5	Connectivity combinations .....	54
Table 6	UPS component service life .....	59
Table 7	Battery voltage, nominal and float .....	61
Table 8	Battery retorque values .....	62
Table 9	Environmental specifications .....	66
Table 10	Electrical specifications .....	67
Table 11	Physical specifications .....	67

# IMPORTANT SAFETY INSTRUCTIONS

## SAVE THESE INSTRUCTIONS

This manual contains important instructions that should be followed during installation of your Liebert NX UPS. Read this manual thoroughly, paying special attention to the sections that apply to your installation, before working with the UPS. Retain this manual for use by installing personnel.

### **WARNING**

Risk of electric shock. Can cause equipment damage, injury or death.

This UPS has several circuits that are energized with high DC as well as AC voltages. Check for voltage with both AC and DC voltmeters before working within the UPS. Check for voltage with both AC and DC voltmeters before making contact.

Only properly trained and qualified personnel wearing appropriate safety headgear, gloves, shoes and glasses should be involved in installing the UPS or preparing the UPS for installation. When performing maintenance with any part of the equipment under power, service personnel and test equipment should be standing on rubber mats.

In case of fire involving electrical equipment, use only carbon dioxide fire extinguishers or those approved for use in fighting electrical fires.


Extreme caution is required when performing installation and maintenance.

Special safety precautions are required for procedures involving handling, operation and maintenance of the UPS system. Observe all safety precautions in the installation manual, SL-25535, and in this manual before as well as during performance of all maintenance procedures. Observe all DC safety precautions before working on or near the DC system.

### **WARNING**

Risk of heavy unit falling over. Improper handling can cause equipment damage, injury or death.

Exercise extreme care when handling UPS cabinets to avoid equipment damage or injury to personnel. The UPS module weight is up to 4450lb. (2019kg).

Locate center of gravity symbols  and determine unit weight before handling each cabinet. Test lift and balance the cabinets before transporting. Maintain minimum tilt from vertical at all times.

Slots at the base of the module cabinets are intended for forklift use. Base slots will support the unit only if the forks are completely beneath the unit.

Read all of the following instructions before attempting to move, lift, or remove packaging from unit, or prepare unit for installation

### **WARNING**

Risk of electric shock and fire. Can cause equipment damage, personal injury or death.

Under typical operation and with all UPS doors closed, only normal safety precautions are necessary. The area around the UPS system should be kept free of puddles of water, excess moisture and debris.

Only test equipment designed for troubleshooting should be used. This is particularly true for oscilloscopes. Always check with an AC and DC voltmeter to ensure safety before making contact or using tools. Even when the power is turned Off, dangerously high potential electric charges may exist at the capacitor banks and at the DC connections.

All wiring must be installed by a properly trained and qualified electrician. All power and control wiring must comply with all applicable national, state and local codes.

One person should never work alone, even if all power is disconnected from the equipment. A second person should be standing by to assist and to summon help in case of an accident.



## Battery Cabinet Precautions

The following warning applies to all battery cabinets supplied with UPS systems. Additional warnings and cautions applicable to battery cabinets may be found in **Important Safety Instructions on page 1** and **5.4 - Battery Maintenance**.

### **WARNING**

Risk of electric shock, fire and smoke. Can cause equipment damage, injury and death.

Internal battery strapping must be verified by manufacturer prior to moving a battery cabinet after initial installation.

- Battery cabinets contain non-spillable batteries.
- Keep units upright.
- Do not stack.
- Do not tilt.

Call 1-800-LIEBERT before moving battery cabinets after initial installation.

For systems using DC sources other than batteries, refer to the manufacturer's recommendations for handling and care.



### **NOTE**

*Materials sold hereunder cannot be used in the patient vicinity (e.g., use where UL, cUL or IEC 60601-1 is required). Medical applications such as invasive procedures and electrical life support equipment are subject to additional terms and conditions.*

### **NOTICE**

This unit complies with the limits for a Class A digital device, pursuant to Part 15 Subpart J of the FCC rules. These limits provide reasonable protection against harmful interference in a commercial environment. This unit generates, uses and radiates radio frequency energy and, if not installed and used in accordance with this instruction manual, may cause harmful interference to radio communications. Operation of this unit in a residential area may cause harmful interference that the user must correct at his own expense.

# 1.0 INTRODUCTION

## 1.1 GENERAL DESCRIPTION

The Liebert NX UPS is a maximum-efficiency UPS that provides continuous, high-quality AC power to business-critical equipment, such as telecommunications and data processing equipment. The Liebert NX UPS supplies power that is free of the disturbances and variations in voltage and frequency common to utility power, which is subject to brownouts, blackouts, surges and sags.

The Liebert NX utilizes the latest in high-frequency, double-conversion pulse-width modulation, transformer-free technology and fully digital controls to enhance its reliability and efficiency and increase the ease of use.

As shown in **Figure 1**, the AC utility source is input to the rectifier which converts the AC utility into DC power at the DC bus operating voltage. This feeds the inverter and the DC/DC booster/charger. The inverter converts that DC power from the rectifier—or DC power from the DC source (via the booster/charger)—into AC power for the load.

The DC source will power the load through the inverter in the event of a power failure. When the system is being powered by the utility, the booster/charger converts a portion of the DC power from the rectifier to a voltage suitable for charging the batteries or other DC source. When the load is being powered by the DC source, the booster/charger converts the DC source output to the voltage needed to drive the inverter.

The utility source can also power the load through the static bypass.

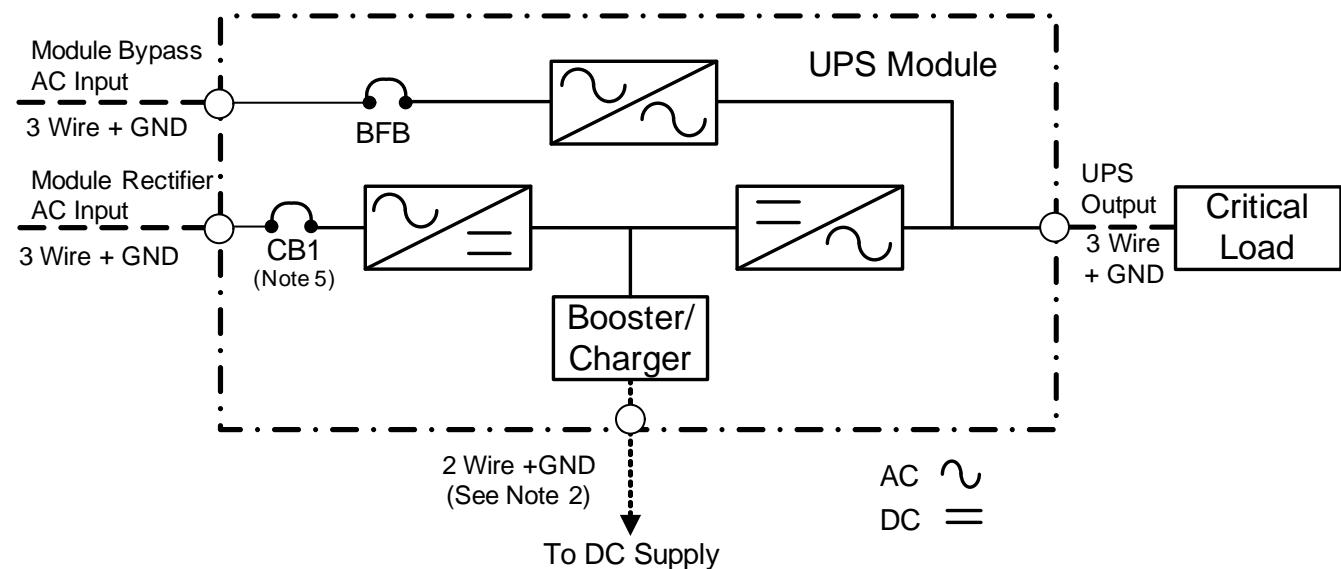
If maintenance or repair of the UPS is necessary, the load can be switched without interruption in service to an external maintenance bypass.



### NOTE

Vertiv recommends that the Liebert NX 225-600kVA always be installed with a maintenance bypass system that fully isolates the UPS from the load and the AC power source. This allows service personnel to safely repair the UPS if needed while maintaining power to the critical load.

**Figure 1** Typical single module UPS system one-line diagram



1. UPS rectifier bypass input and output cables must be run in separate conduits.
2. All power cables from DC supply should be sized for a total maximum of 2V drop at maximum discharge current.
3. Control wiring and power wiring must be run in separate conduits.
4. Vertiv recommends installing grounding conductors.
5. Standard configuration has CB1 removed. If CB1 is required, option must be ordered.

## 1.2 MODES OF OPERATION

### 1.2.1 Normal Mode

Operating in normal mode, the Liebert NX's rectifier derives power from a utility AC source and supplies regulated DC power to the inverter, which regenerates precise AC power to supply the connected equipment. The rectifier also uses the utility source power to charge the DC sources.

### 1.2.2 Eco Mode

When the Liebert NX 225-600 kVA is in Eco Mode, the load will be supported by the bypass source as long as the power quality of the bypass source remains within specified limits. This reduces energy consumption and boosts efficiency to greater than 98%. If the power quality of the bypass source deviates from acceptable levels, the inverter will take the load and the UPS will operate in normal mode. It will remain in normal mode until the power quality of the bypass source has remained within limits for a suitable time, at which point the Liebert NX will return to Eco Mode.

Eco Mode may be inhibited either automatically, such as when the Liebert NX is being fed by a generator source, or manually, by sending a signal to one of the programmable input contacts. Examples of control circuits to provide this functionality and a more detailed explanation of Eco Mode operation can be found in **2.6 - Eco Mode Active**.

### 1.2.3 Bypass Mode

When the Liebert NX is in bypass mode, the load is directly supported by utility power and is without DC source backup protection.

The Liebert NX's inverter and bypass static switch will shift the load from the inverter to bypass mode without an interruption in AC power if the inverter is synchronous with the bypass and any of the following occurs:

- Inverter fails
- Inverter overload capacity is exceeded
- Inverter is manually turned Off by the user
- UPS is operating on battery and battery voltage reaches end of discharge level



#### NOTE

*If the inverter is not in sync with the bypass, the static switch will transfer the load from the inverter to the bypass WITH interruption in AC power to the critical load. The default interruption time is 16ms; the minimum is 4ms. Vertiv Liebert Services™ can adjust the length of the interruption.*

### 1.2.4 Battery Mode

When utility AC power fails, the Liebert NX protects the critical load by instantaneously channeling DC source power to the inverter, which continues supporting the critical load without interruption.

When utility power returns and is within acceptable limits, the Liebert NX automatically shifts back to Normal mode, with the rectifier powering the critical load.

### 1.2.5 Maintenance Bypass

The installation of a Maintenance Bypass Cabinet or Assembly is recommended to allow you to totally isolate the UPS from all power sources. Use of the Maintenance Bypass is described in **2.0 - Operation**.

## 1.3 OPTIONS

A number of options are available from Vertiv for your UPS system. Some options are not available for all ratings. Described below are the most frequently provided options. Other options are available. Contact your Vertiv sales representative for more information.

- LIFE Services™—A remote service delivery capability which enables the UPS to alert a special Liebert Services Support Center to provide more efficient and proactive identification, resolution, and prevention of potential UPS issues.
- Network and BMS Connectivity and Monitoring—Communication cards support SNMP, Modbus or both (Dual Protocol)
- Battery and Racks—The batteries provide power in the event of a power outage. The Liebert NX UPS can use a variety of battery types, provided the battery plant is designed for the UPS DC voltage range and the load requirements of your application.
- Battery Cabinets—Valve-regulated, lead-acid (VRLA) sealed batteries are available in matching cabinets for convenient installation and maintenance in otherwise unprotected space. Depending on the UPS module rating, two or more cabinets may be connected in parallel to provide the additional run time.
- Module Battery Disconnect—The UPS system utilizes a separate Module Battery Disconnect for remotely located batteries. A sensing circuit in the UPS module, set at the battery low voltage limit, trips the Module Battery Disconnect to safeguard the battery from excessive discharge. The Module Battery Disconnect has an undervoltage release mechanism designed to ensure that during any shutdown or failure mode all battery potential is removed from the UPS system.
- Battery DC Ground Fault Detection—Monitors battery ground fault current and generates a warning on the UPS touchscreen LCD and other customer-specific annunciation options.
- Maintenance Bypass—This switchboard provides make-before-break maintenance bypass. It includes: Maintenance Bypass Breaker (MBB) and Maintenance Isolation Breaker (MIB).
- Load Bus Synchronization—The Load Bus Sync (LBS) option keeps independent UPS systems (and therefore their critical load buses) in sync, even when the modules are operating on DC source or asynchronous AC sources. This means that critical loads connected to both load buses can switch seamlessly between the two.
- MultiBus Synch Module (MBSM)—Permits synchronizing operation of up to 11 UPS modules.
- Input Circuit Breaker—The UPS may be equipped with an internal input circuit breaker (CB1).
- Remote Status Panel—This option provides key status indicators. If ordered with your UPS, the power supply for this option is factory installed. To add this option to a unit which has already been shipped contact Liebert Service.
- EPO (Emergency Power Off)—Your UPS may be equipped with an EPO button on its front panel near the operator touch screen. Contacts for a remote EPO to be installed on site are also provided standard on all units.
- Temperature-Compensated Charging—When the battery temperature exceeds a preset limit (typically 77°F [25°C]), this optional circuit proportionally reduces float charging voltage to prevent overcharging the battery.
- Battery Load Testing—When activated, this option forces the battery string to assume the load for a short period of time.
- Common Battery for Two Modules—Two Liebert NX 225-600kVA units may share a common battery plant if the following conditions are met:
  - The UPS modules are of the same capacity and their output is paralleled
  - A Special Features Authorization (SFA) was ordered with the unit to include special current sensors (LEM's)
  - The system is configured as shown in **Figure 40**.
  - No more than two UPS modules may share one battery.

## 2.0 OPERATION

The Liebert NX UPS is equipped with a microprocessor-based display touchscreen designed for convenient and reliable operation. The display is driven by menu-prompted software.

### 2.1 PHYSICAL LAYOUT OF THE UPS

Figure 2 Main component locations—225-300kVA Liebert NX

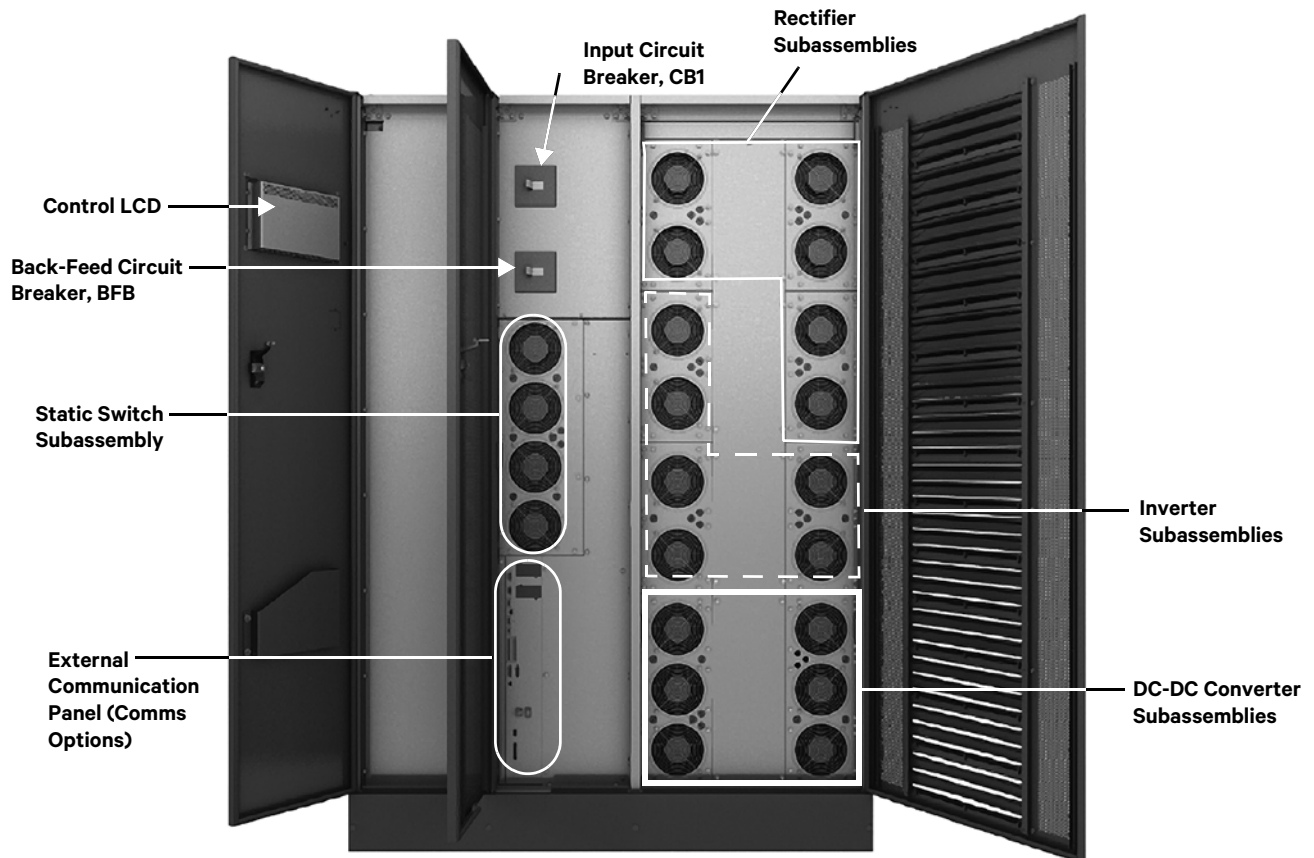
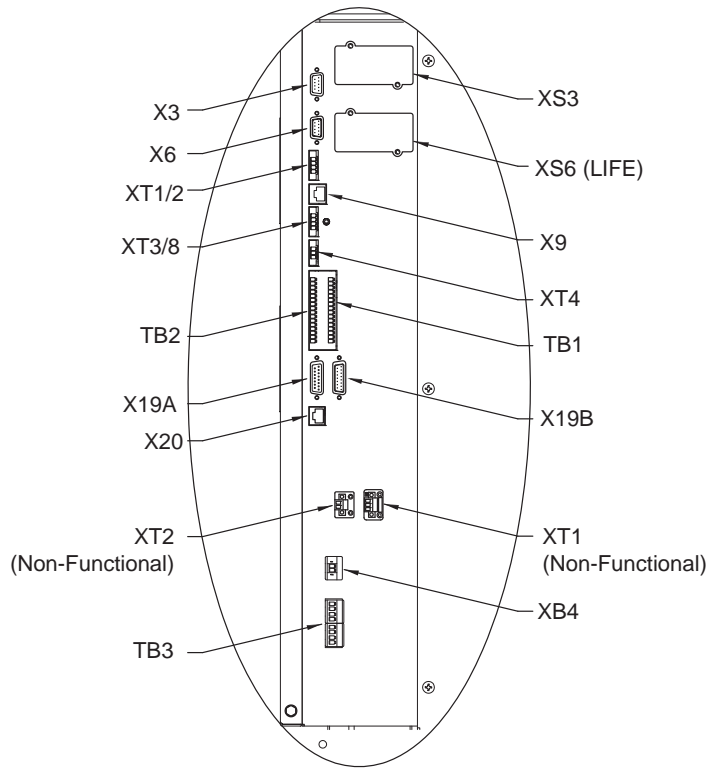
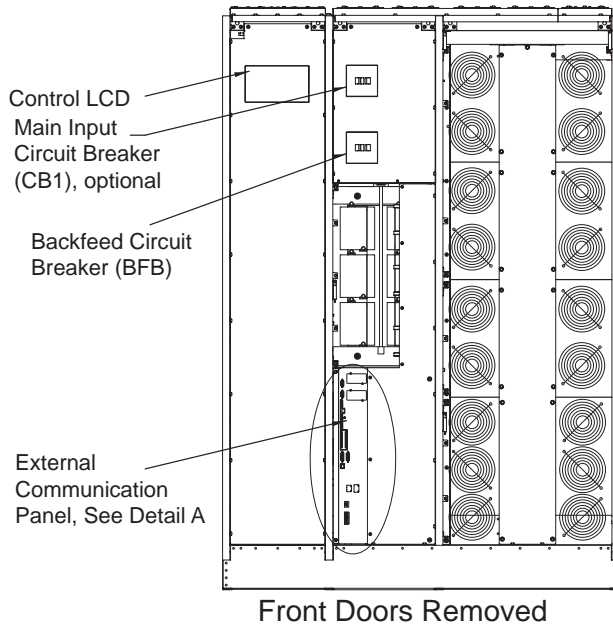
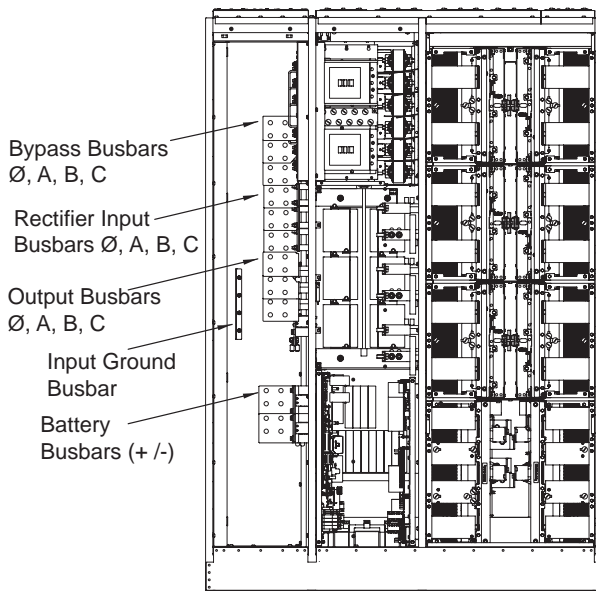


Figure 3 Main component details—225 to 300kVA Liebert NX



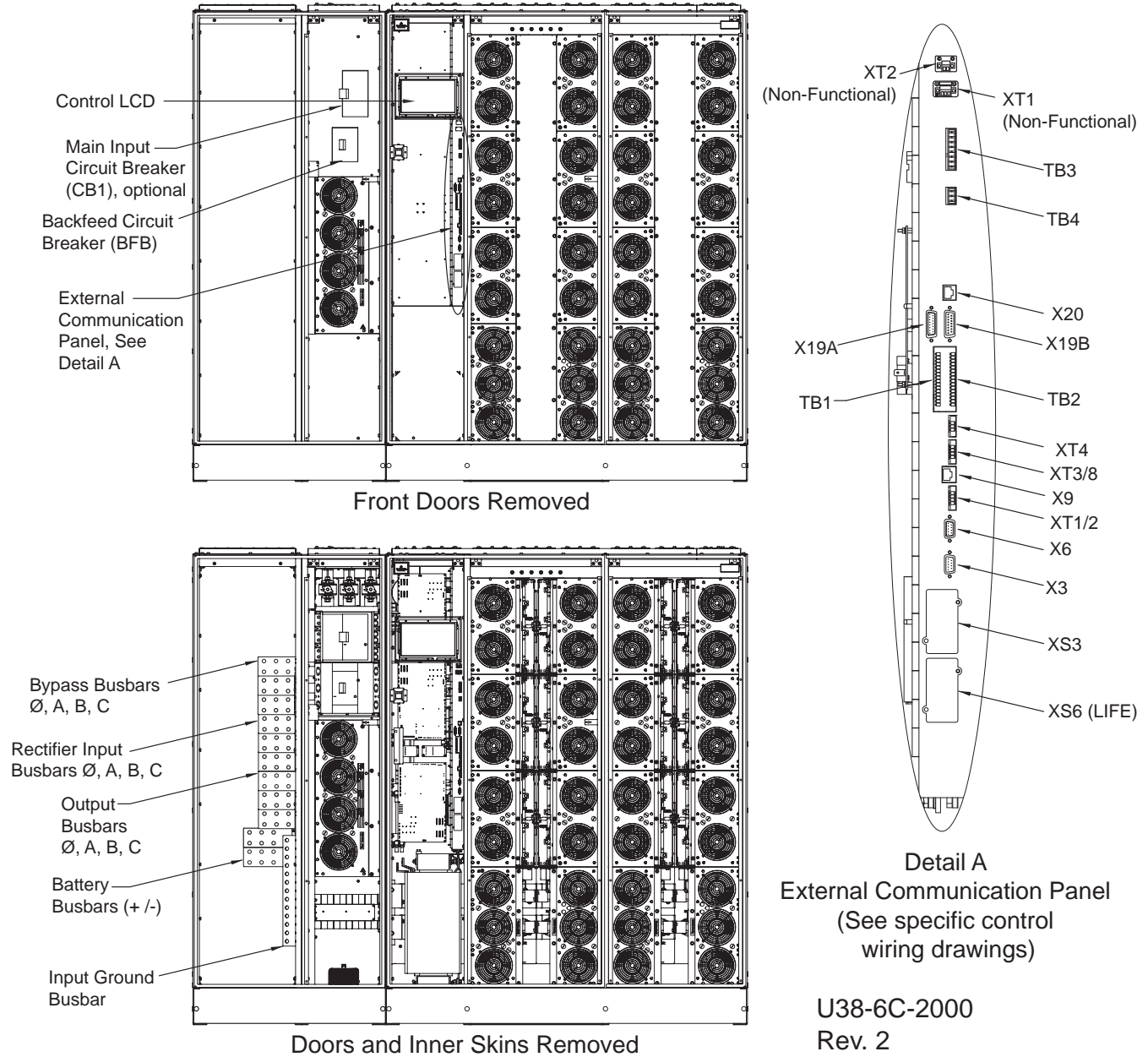
Detail A  
External Communication Panel  
(See specific control wiring drawings)



Doors and Inner Skins Removed

U38-3C-2000  
Rev. 2

**Figure 4 Main component details, 400-600kVA Liebert NX**



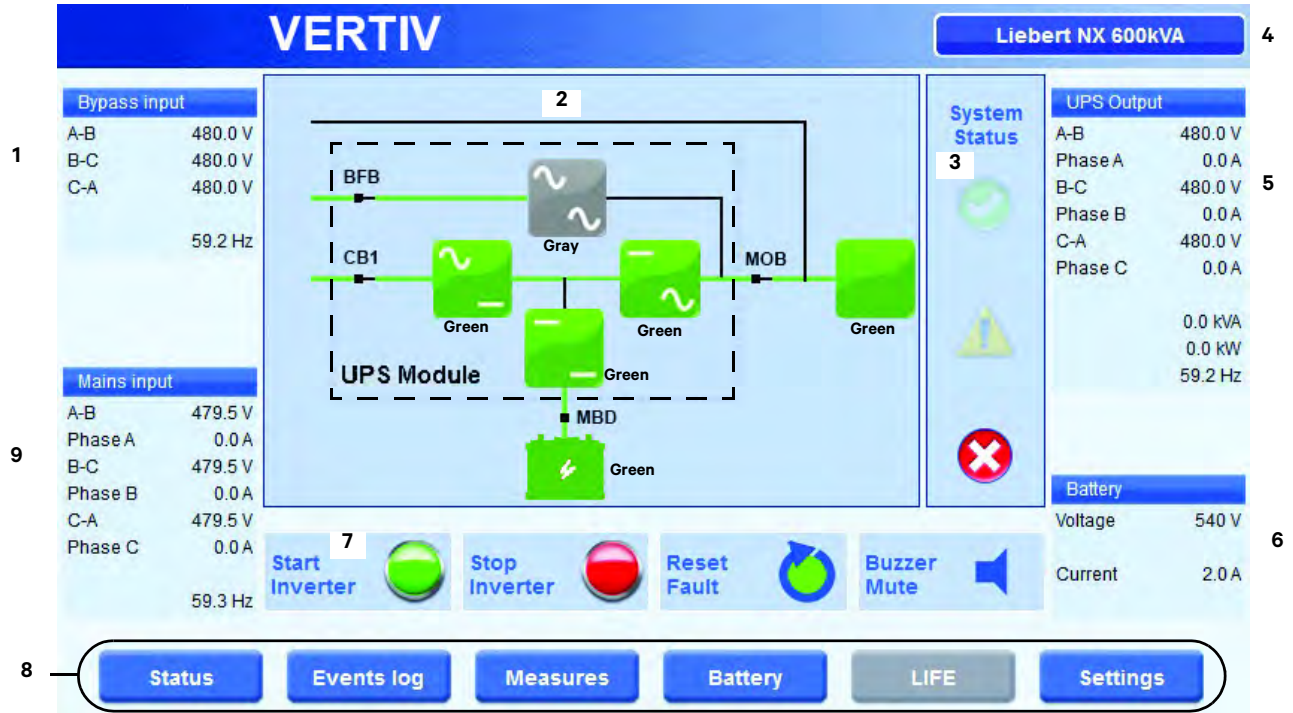
## 2.2 INTERFACE DISPLAY FEATURES

The Liebert NX interface display enables the operator to perform such tasks as:

- Check operational status
- Monitor the power flow through the UPS system and all meter readings
- Execute operational procedures
- Check status reports and event files
- Adjustment programmable parameters

The touchscreen display has a blue background and multicolored text. The display turns On automatically, but dims and the back-light goes out after 15 minutes of inactivity. Touching the screen will reactivate the back-light for 15 minutes. If any screen other than the mimic screen is accessed, that screen will be displayed for 5 minutes without any interaction. If there is no activity for 5 minutes, the display will revert to the basic mimic screen.

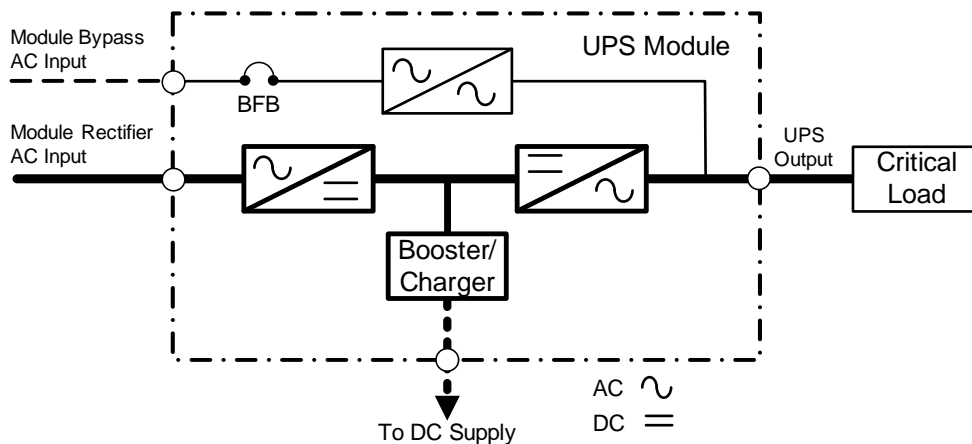
Figure 5 Main display screen, typical



- 1. Bypass Input: Voltage and frequency readings
- 2. Animated One Line Mimic
- 3. System Status
- 4. About Button
- 5. Output: Voltage, current and frequency readings
- 6. Battery: Voltage and current readings
- 7. Control Buttons
- 8. Menu Buttons
- 9. Line power Input: Voltage, current and frequency readings

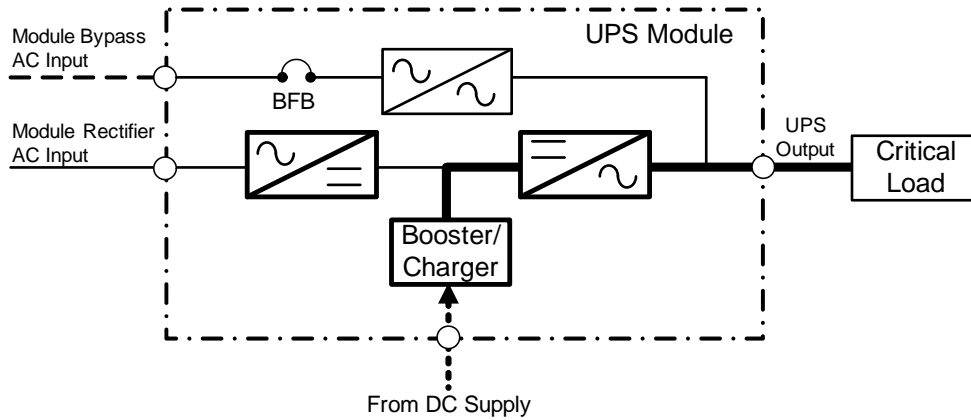
**COLOR CODE FOR ICONS AND POWER PATH LINES**  
 Green = OK and In the Active Power Path  
 Gray = Not Active  
 Yellow = Advisory  
 Red = Faulted or Disabled

Figure 6 Normal Mode

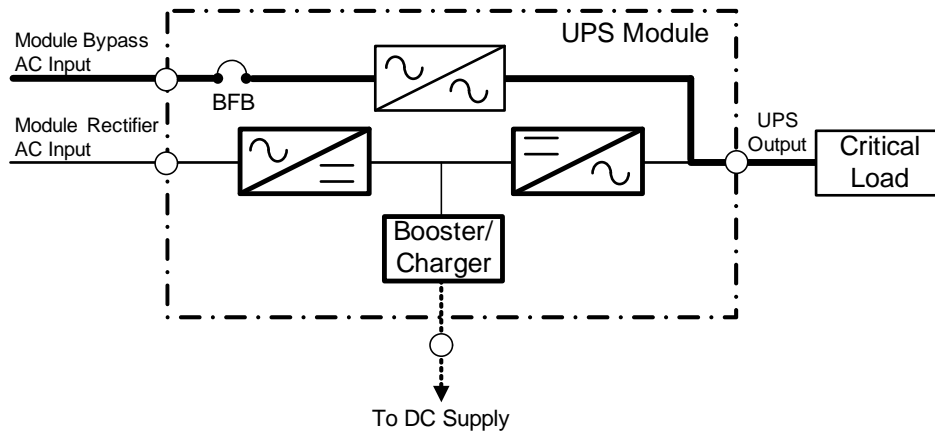




**Figure 7 Utility fail**



**Figure 8 Load on bypass**



## 2.3 TOUCHSCREEN NAVIGATION

Several menu items can be accessed from the main display screen (see **Figure 17**). These menu items are detailed in subsequent sections.

### 2.3.1 Main Display Screen

This is the default screen. It displays the following information:

- Bypass Input Voltage
- Bypass Input Frequency
- Input Voltage
- Input Current
- Input Frequency
- Output Voltage
- Output Current
- Output Frequency
- DC Source Voltage
- DC Source Current

## System Status

Only one of the following three status indicators is actively highlighted at any given time:

**System Normal Indicator**—When the green check mark status icon (✓) is highlighted, the system is operating normally and no warning or alarm has occurred. During line power failures (with all other conditions being nominal), this icon is not highlighted.

**Warning Indicator**—The yellow triangle icon is activated and highlighted by abnormal conditions that could affect the normal operation of the UPS. These conditions do not originate with the UPS, but may be caused either by the surrounding environment or by the electrical installation (line power side and load side). A description of the active warning(s) can be viewed by touching the yellow triangle or using the Status button at the bottom of the page.

**Fault Indicator**—When the red circle with white cross is highlighted, immediate attention should be given to the severity of the alarm, and service should be called promptly. A description of the active alarm(s) can be viewed by touching the Status button at the bottom of the page.

No matter which indicator is active, all available diagnostic information on the unit can be displayed by touching this area.

**Control Buttons: Start Inverter and Stop Inverter**—The touchscreen display features two buttons for starting and shutting down the inverter. The start/stop control incorporates a safety feature for preventing accidental operation. When the start or stop function for the inverter is selected, a pop-up window appears asking for confirmation of the action.

**Reset Fault**—Reset faults (becomes red when there is a system fault).

**Alarm Silence**—Silence the buzzer in the case of an alarm.



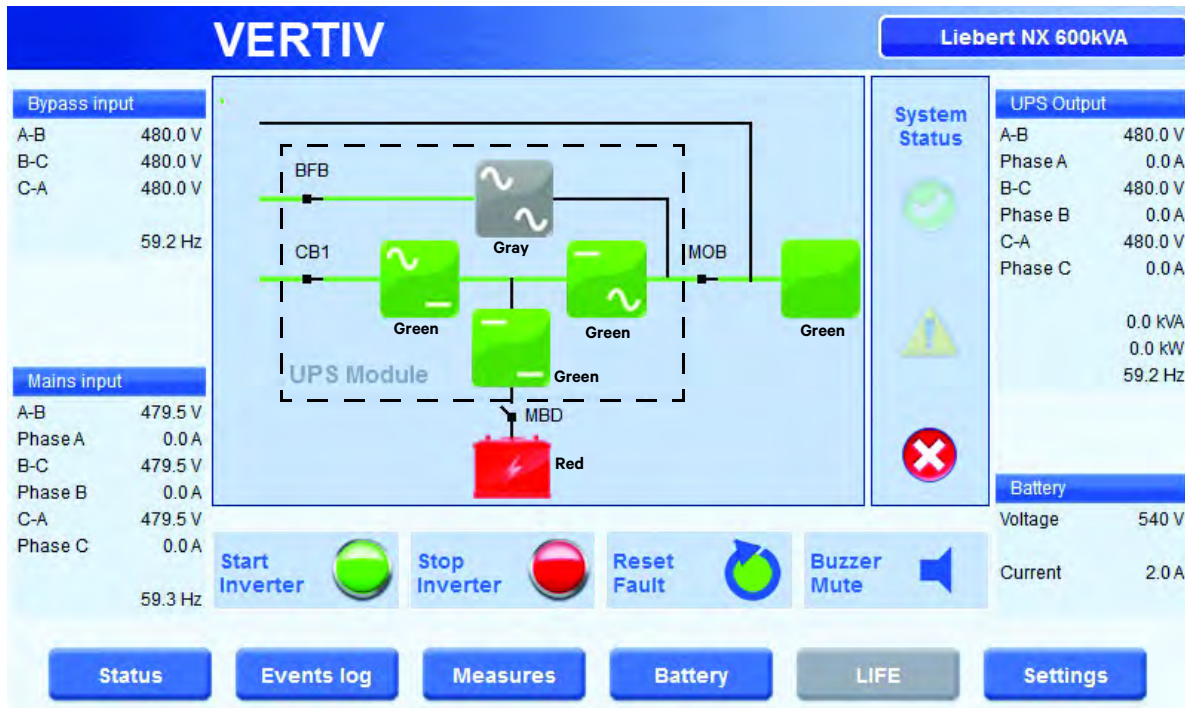
### NOTE

*If screen is inactive for 30 seconds, the LCD will revert to the system status screen.*

## 2.3.2 Status

This menu item displays a Status summary of warnings, faults and other events, as well as status screens for each functional block, such as Rectifier, Inverter and Load.

**Figure 9 Main display screen, MBD open**



In this case, the UPS is operating in double-conversion mode without power backup. All power paths (except the internal bypass and maintenance bypasses lines) are green (active). The bypass static switch and the bypass lines are gray, indicating that they are not active.

**Figure 10 Load status**

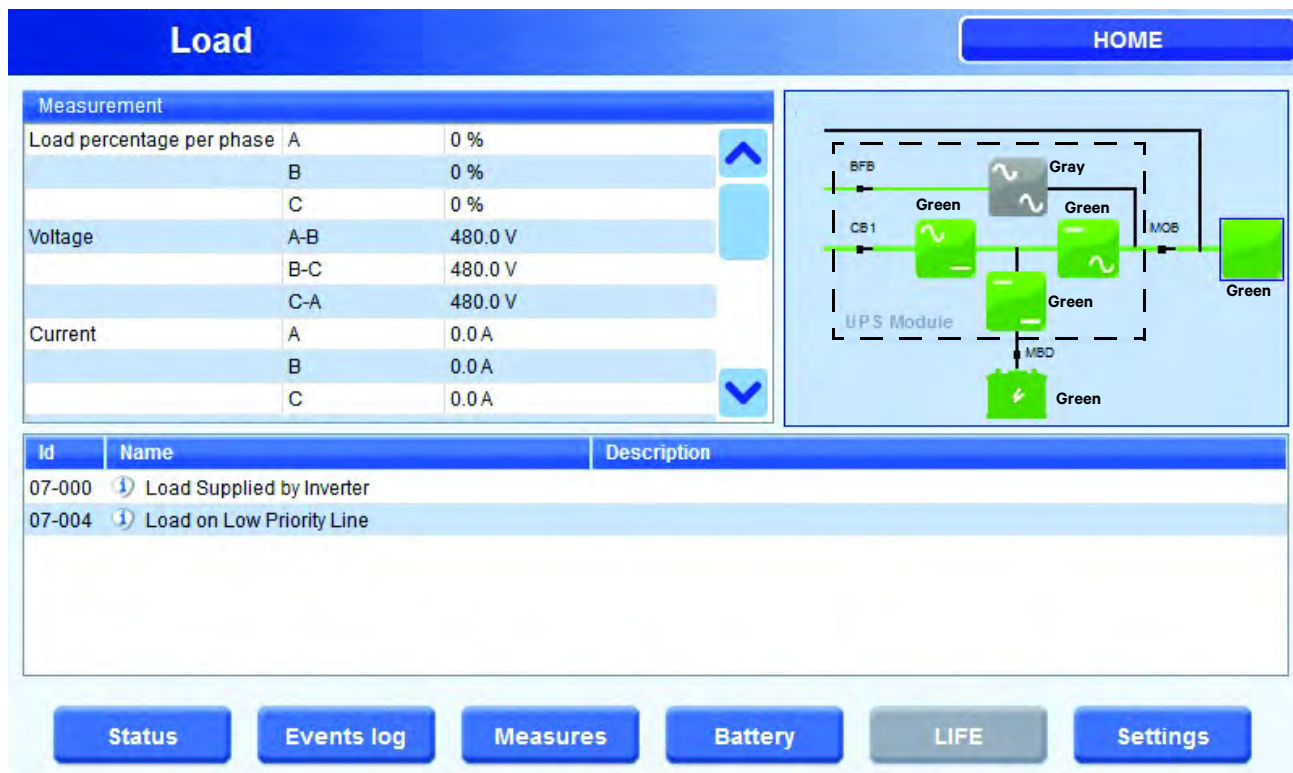


Figure 11 Rectifier status

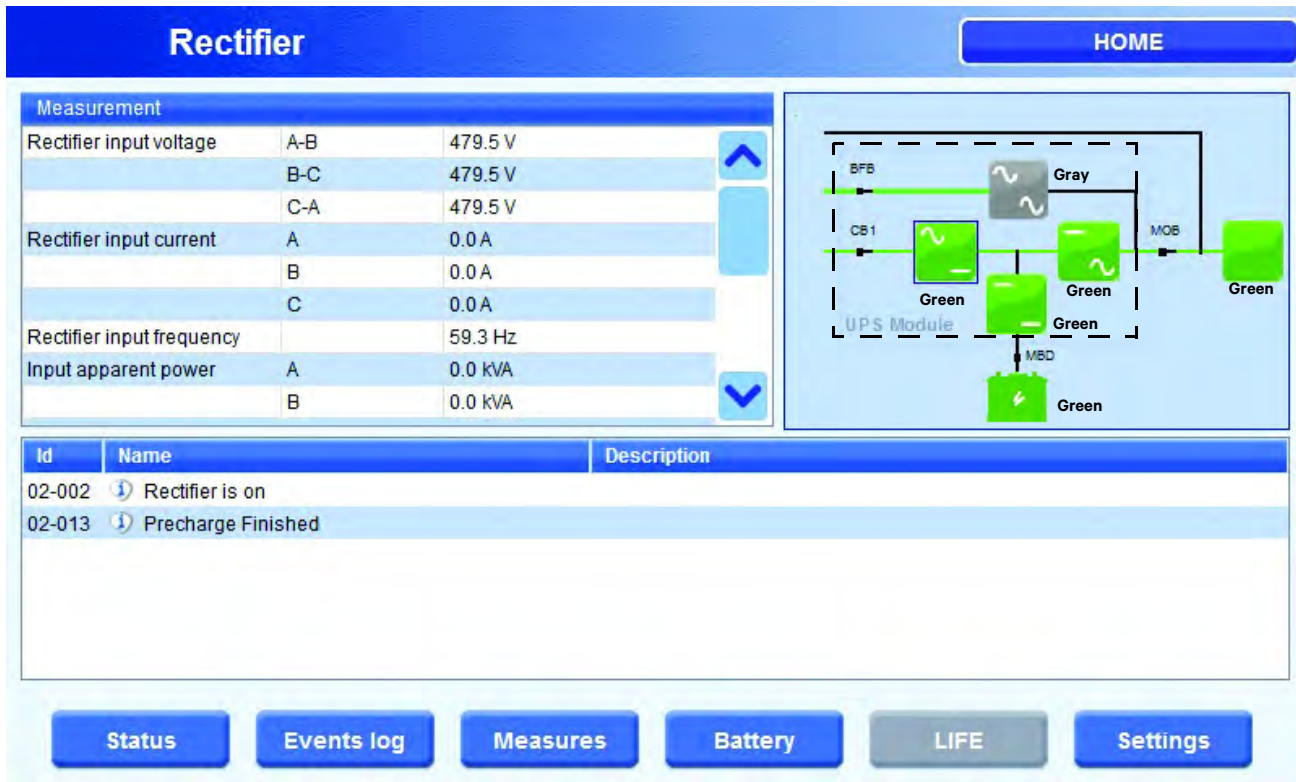
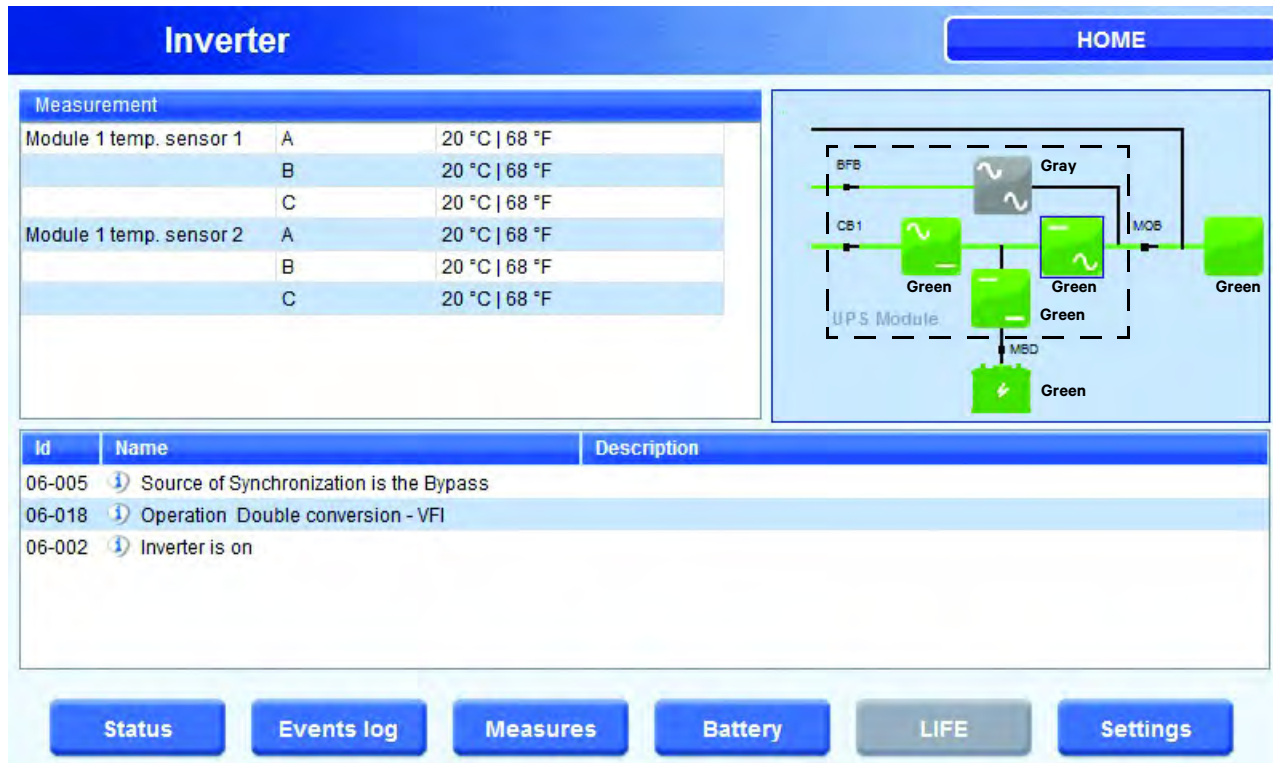


Figure 12 Bypass status



**Figure 13 Inverter status**



**Figure 14 Charger/Booster status**

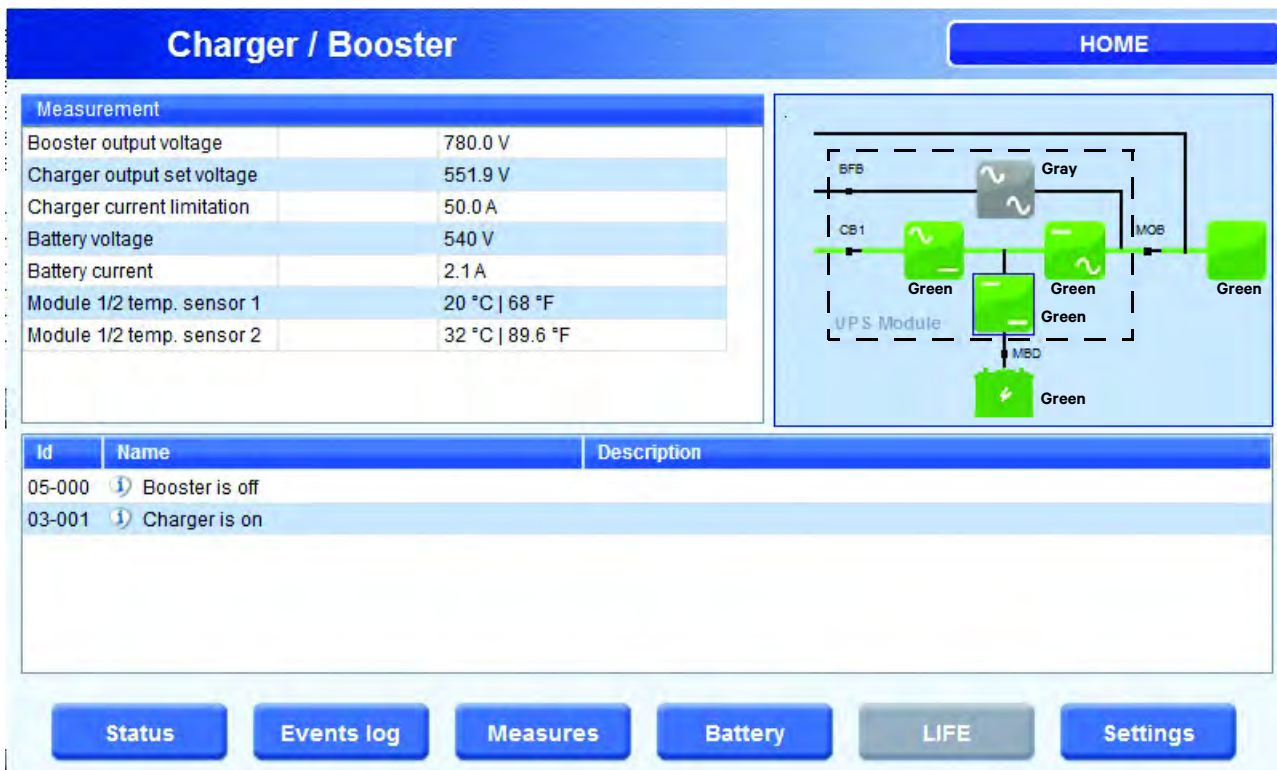


Figure 15 Battery status

Battery
HOME

Measurement	
Battery voltage	540 V
Battery current	2.1 A
Temp. sensor 1	20 °C   68 °F
Backup time	19 m
Capacity	80 %

Id	Name	Description
34-009	<span style="color: red;">✖</span> Battery Switch Open	Connect the battery
34-005	<span style="color: red;">✖</span> There is no Battery Connected	Connect the Battery
34-011	<span style="color: red;">✖</span> Resttime exceeded	The calculated battery resttime is now under the low battery signal time
24-039	<span style="color: orange;">⚠</span> Battery #1 is Open	
04-000	<span style="color: blue;">ⓘ</span> Battery Warning	

Status

Events log

Measures

Battery

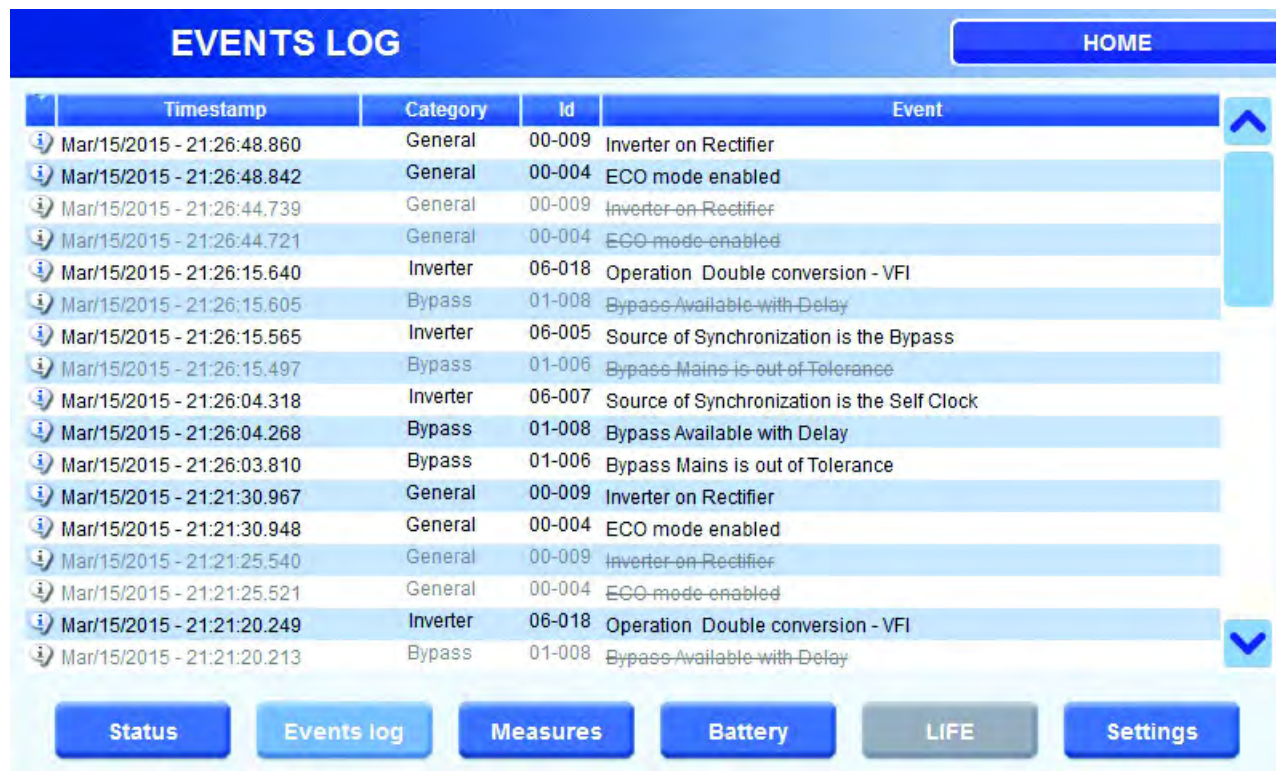
LIFE

Settings

### 2.3.3 Events Log Menu

This menu item displays recent Events that occurred while the UPS was in operation.

Figure 16 Status summary



### 2.3.4 Measures Menu

This menu item displays the full set of measurements for each functional block (rectifier, bypass, booster/charger, batteries, inverter and load).

Table 1 Measurements for functional blocks

Rectifier	Bypass	Inverter	Charger/Booster	Battery	Load
Voltage - L-L	Voltage - L-L	Temperatures	Booster Output Voltage	Battery Voltage	% per phase
Current - Phase	Frequency	—	Booster Output Voltage Setting	Battery Current	Voltage L-L
Frequency	—	—	Charger Current Limit	Temperatures	Current per Phase
kVA per Phase	—	—	Battery Voltage	Backup Time	kW per Phase
Temperatures	—	—	Battery Current	Capacity	kVA per Phase
Rectifier Output Voltage	—	—	Temperatures	—	Frequency
Input Supervision Counter (# of Mains failures)	—	—	—	—	Overload Time Remaining
—	—	—	—	—	Load%
—	—	—	—	—	Total Load Power (kW)
—	—	—	—	—	Total Load Power (kVA)
—	—	—	—	—	Ambient Temperature

Figure 17 Rectifier measures

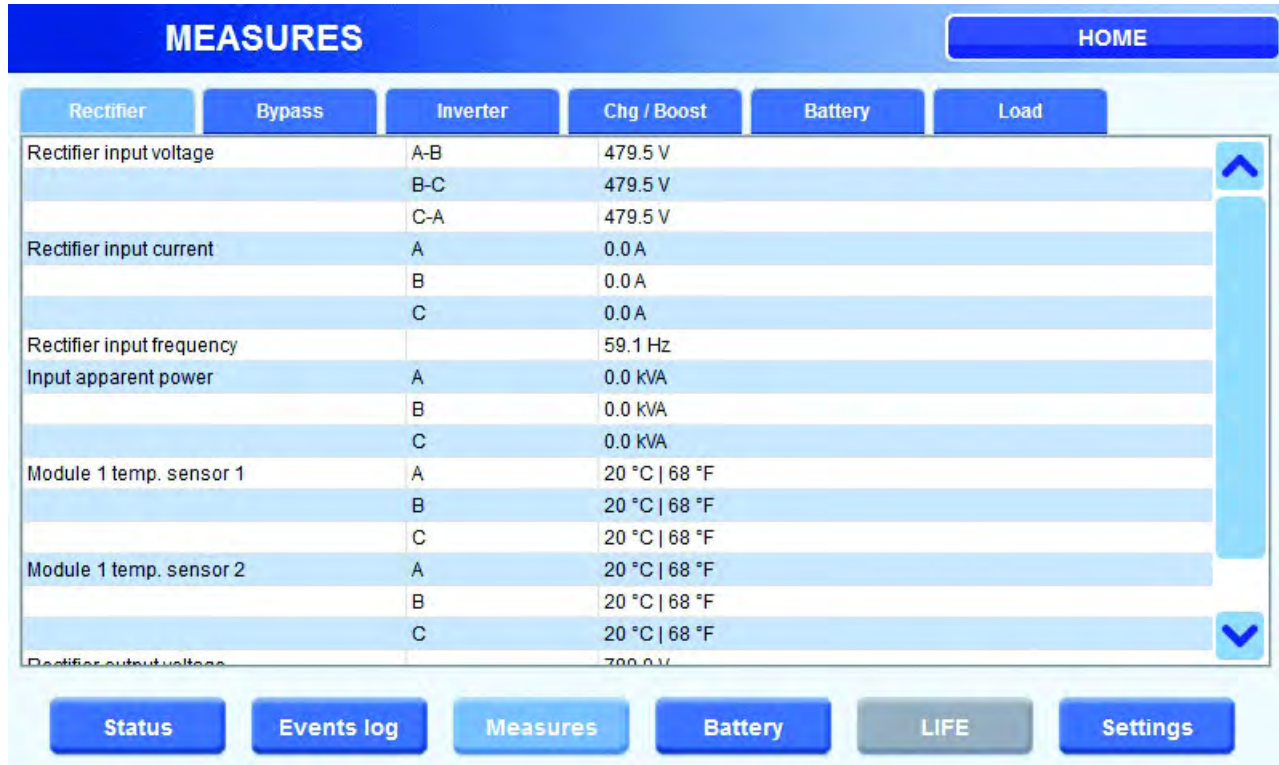


Figure 18 Bypass measures

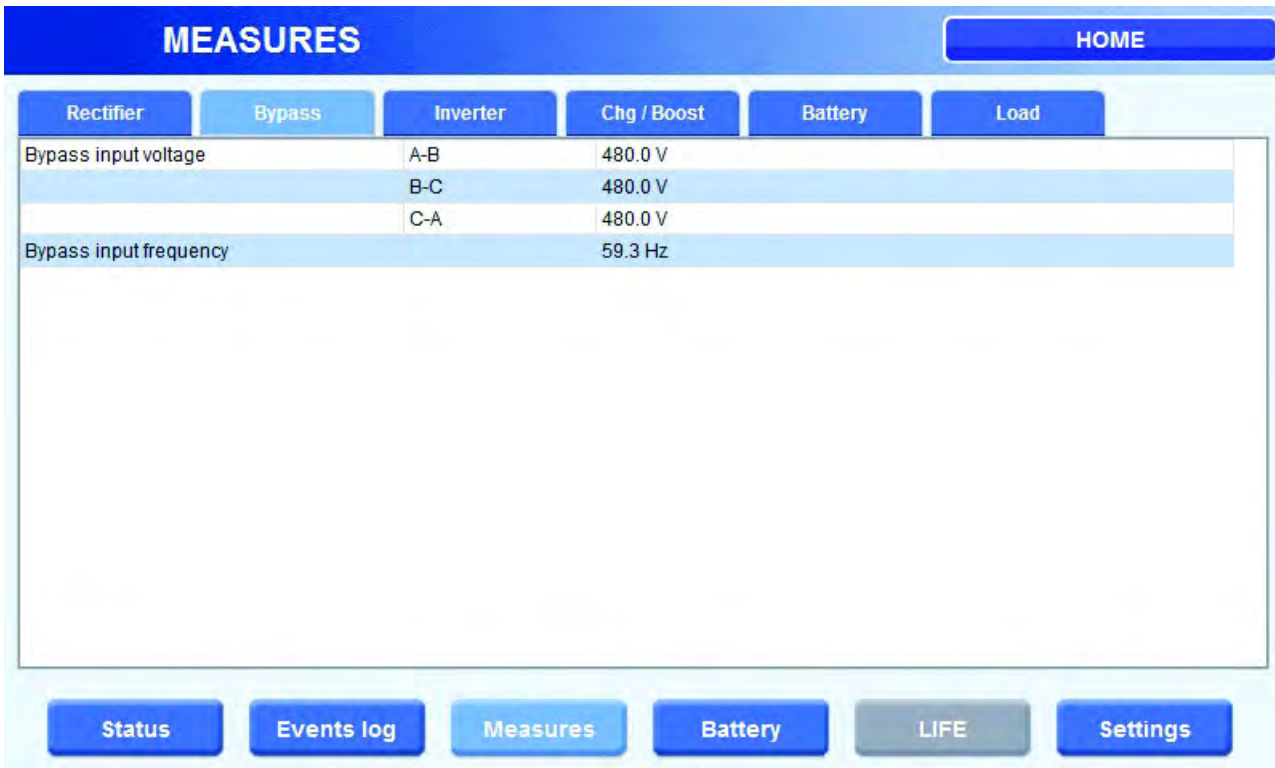




Figure 19 Inverter measures

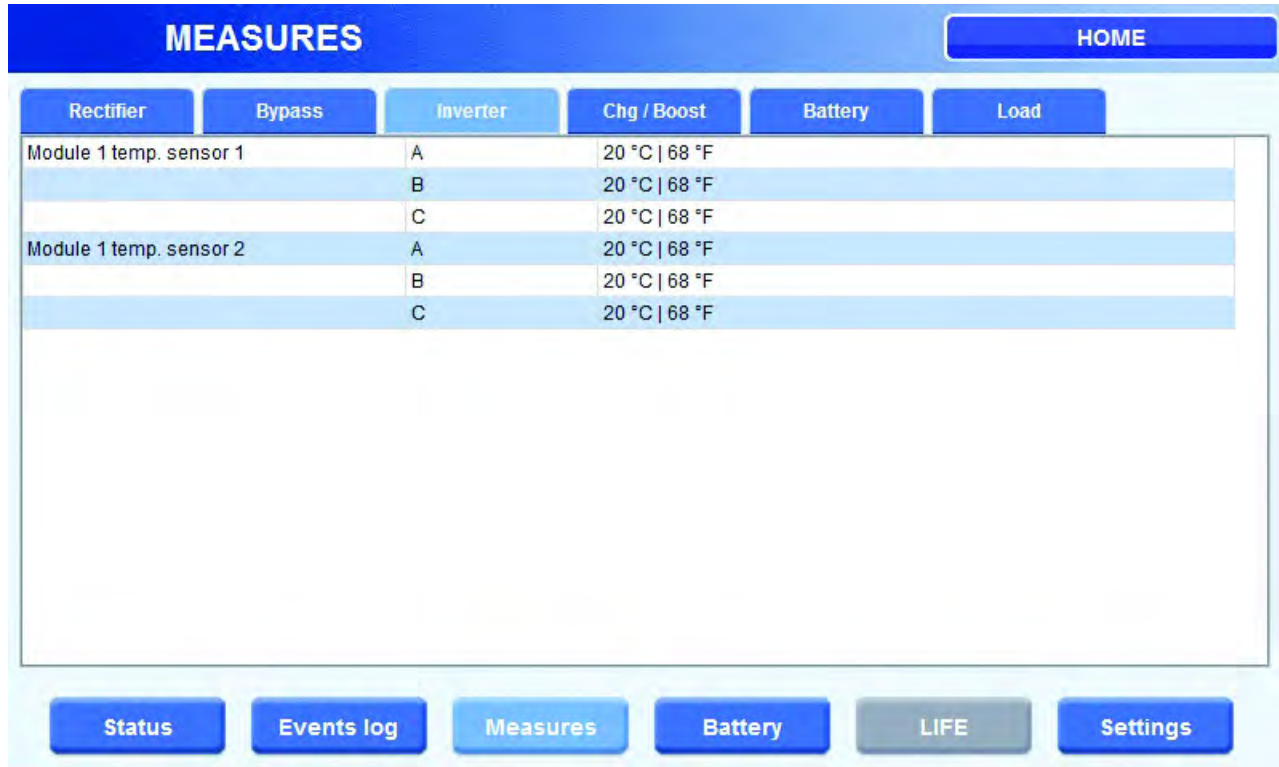


Figure 20 Charger/Booster measures

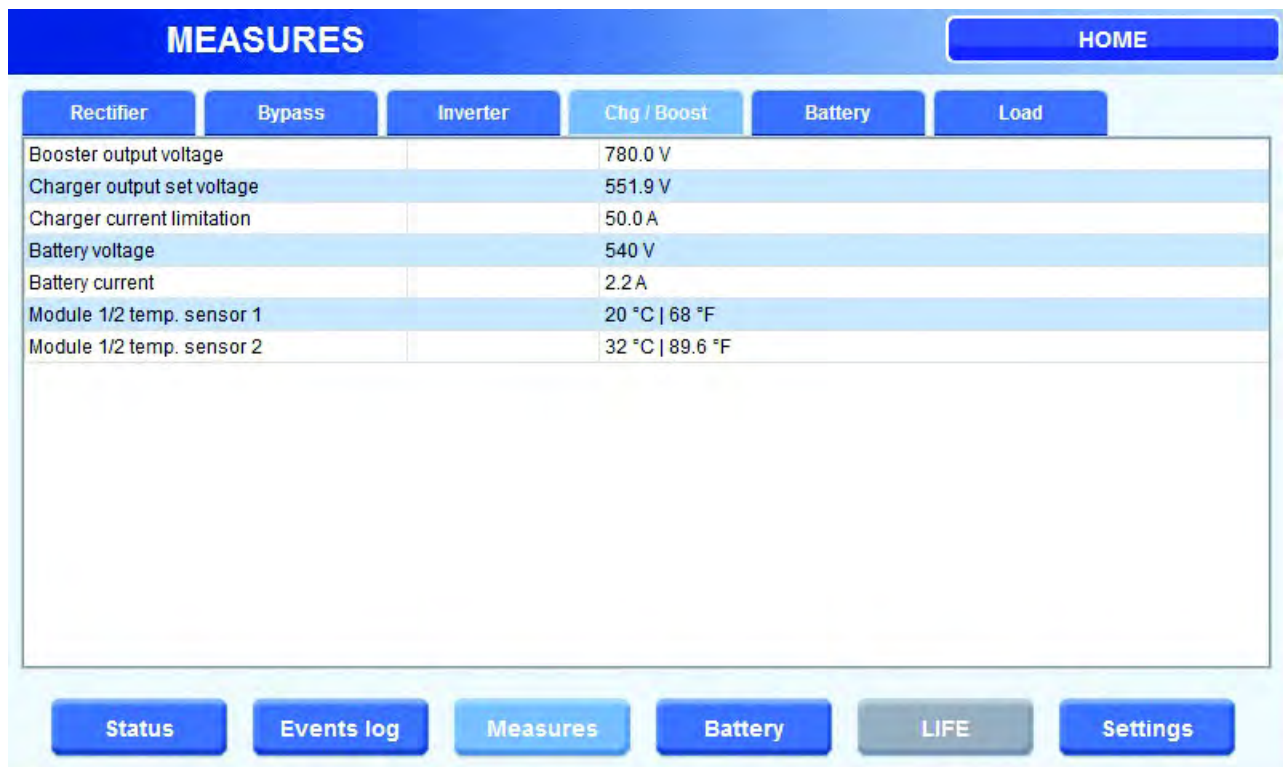


Figure 21 Battery measures

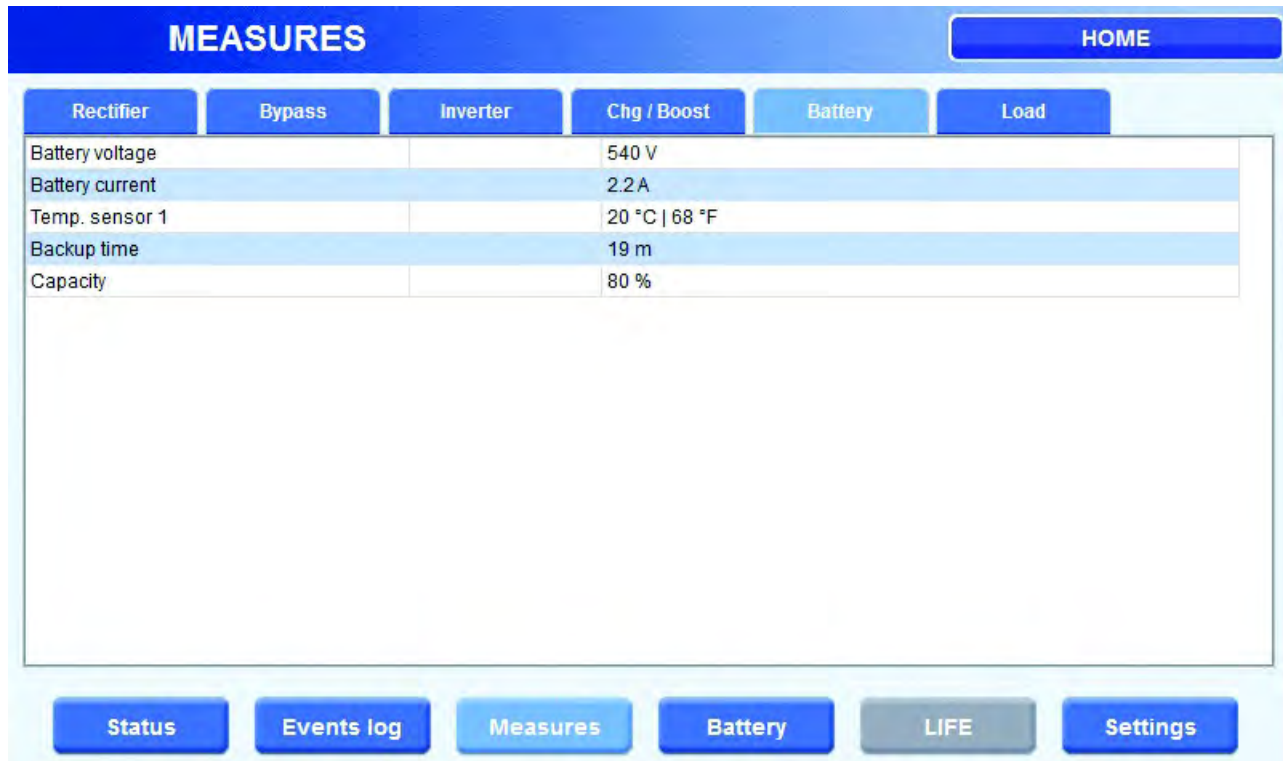
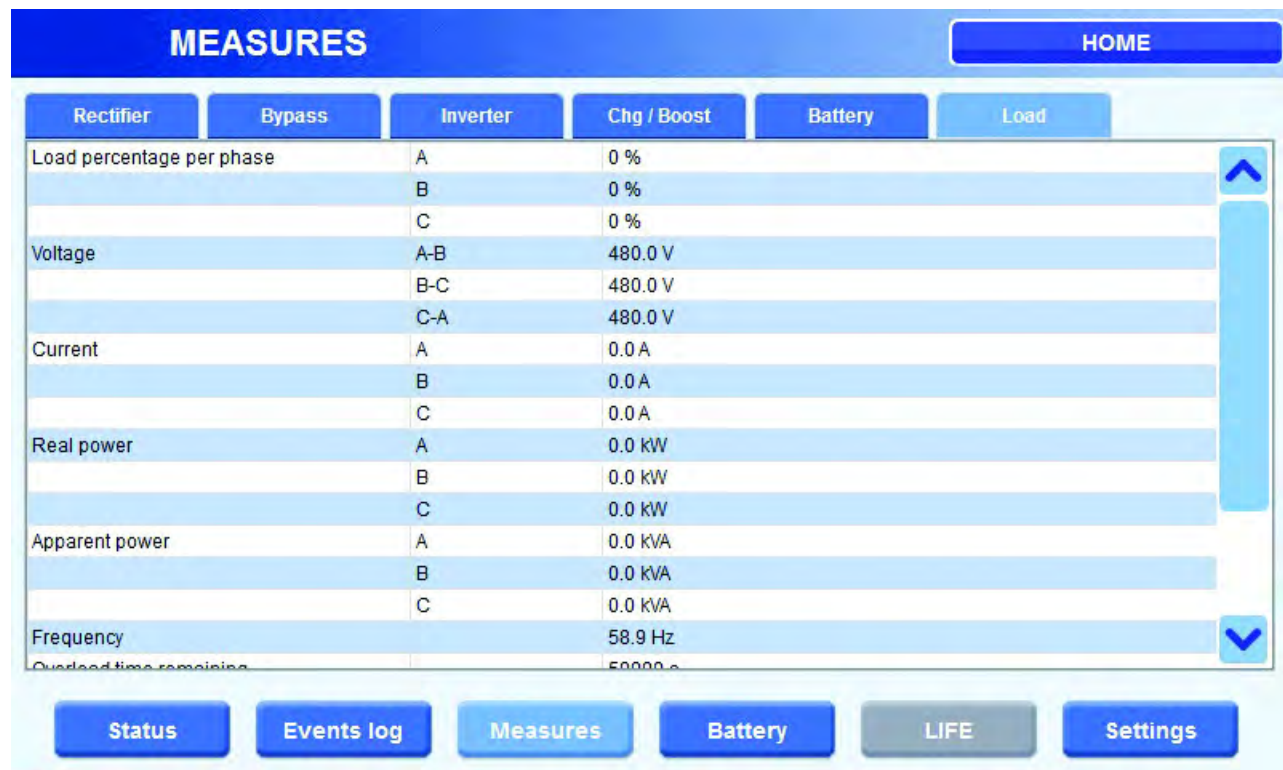


Figure 22 Load measures



### 2.3.5 Battery Menu

This menu displays battery status/parameters, such as temperature, cell voltage, capacity and run time, as well as commands that enable the user to configure and execute a battery test.

#### Battery Status

- Battery Status—Verify whether battery is charging
- Charger Status—Verify Battery Charger status
- Battery Test Status—Verify details of the last battery test executed
- Automatic Battery Test Status—Verify details related to automatic battery test

#### Battery Test

The following commands can be set using this page:

- Enable automatic battery test—Using this command, the Automatic Battery test is enabled using the existing parameter configuration.
- Configure and manage Manual Battery test. Features are:
  - Test duration and Min Voltage can be modified using the + and - buttons
  - Start battery test using dedicated command button (Start Battery Test)
  - Test duration can be monitored on a dedicated progress bar (Battery test progress bar)
  - The battery test can be aborted while it is running with the Stop Battery test button
  - Battery test status provides immediate information about test status

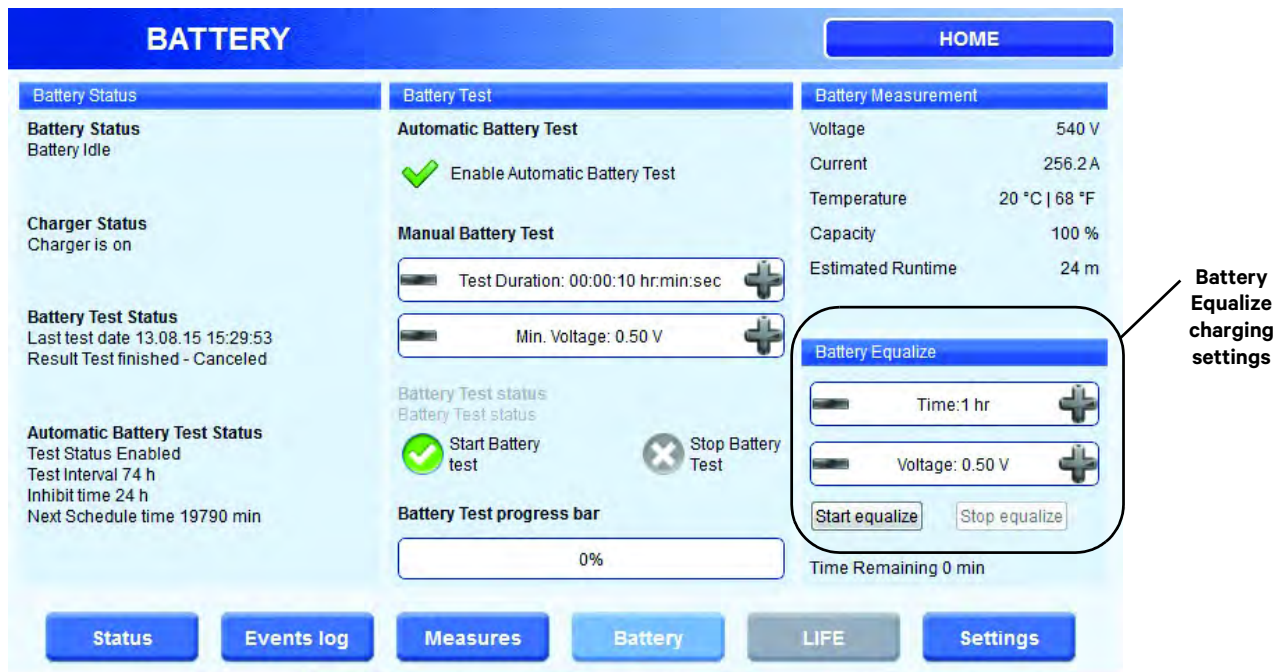
#### Battery Equalize Charging

## WARNING

Risk of electric shock, explosive reaction, hazardous chemicals and fire. Can cause equipment damage, personal injury and death.

Battery equalize charging should be performed only by specially trained personnel or Vertiv Liebert Services personnel. Contact Liebert Services before enabling equalize charging with valve-regulated, lead-acid batteries, such as those used in Liebert battery cabinets. Refer to the battery manufacturer’s manual, available on the manufacturer’s Web site, for specific information about equalize charging

Because individual battery characteristics are not identical and may change over time, the UPS module is equipped with circuitry to equalize battery cell voltages. This circuit temporarily increases charging voltage to maintain flooded type battery cells at full capacity.



The screenshot shows the 'BATTERY' menu interface. It is divided into three main columns: 'Battery Status', 'Battery Test', and 'Battery Measurement'.  
 - **Battery Status:** Shows 'Battery Status: Battery Idle', 'Charger Status: Charger is on', 'Battery Test Status: Last test date 13.08.15 15:29:53, Result Test finished - Canceled', and 'Automatic Battery Test Status: Test Status Enabled, Test Interval 74 h, Inhibit time 24 h, Next Schedule time 19790 min'.  
 - **Battery Test:** Includes 'Automatic Battery Test' with a checked 'Enable Automatic Battery Test' option. Below it is 'Manual Battery Test' with 'Test Duration: 00:00:10 hr:min:sec' and 'Min. Voltage: 0.50 V', both with increment/decrement buttons. It also shows 'Battery Test status' with 'Start Battery test' (checked) and 'Stop Battery Test' (unchecked) buttons, and a 'Battery Test progress bar' at 0%.  
 - **Battery Measurement:** Lists 'Voltage: 540 V', 'Current: 256.2 A', 'Temperature: 20 °C | 68 °F', 'Capacity: 100 %', and 'Estimated Runtime: 24 m'.  
 - **Battery Equalize:** A callout box highlights this section, showing 'Time: 1 hr' and 'Voltage: 0.50 V' with increment/decrement buttons, and 'Start equalize' and 'Stop equalize' buttons. The 'Time Remaining' is 0 min.  
 - **Navigation:** A 'HOME' button is at the top right, and a row of buttons (Status, Events log, Measures, Battery, LIFE, Settings) is at the bottom.

### Battery Measures

This section monitors variables applicable to the battery.

Figure 23 Battery parameters

The screenshot displays the 'BATTERY' control interface with the following sections:

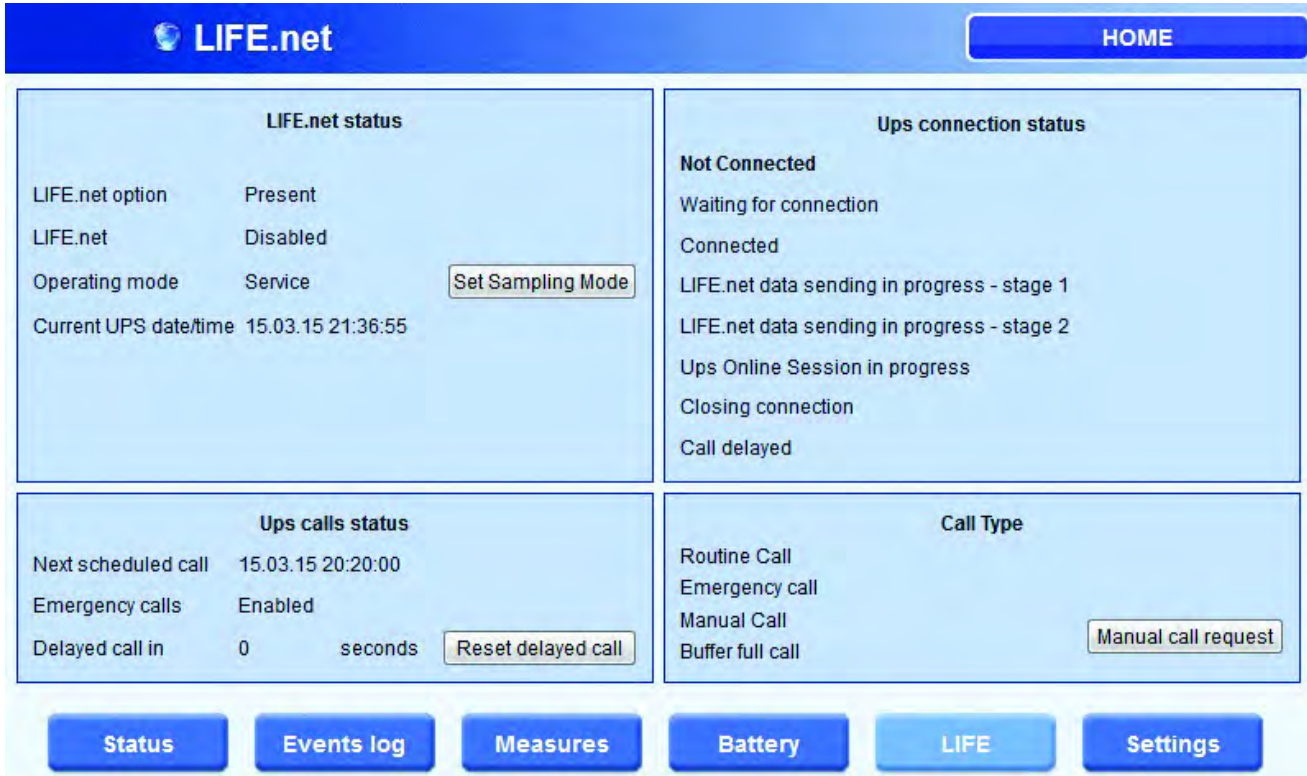
- Battery Status:** Battery Idle; Charger Status: Charger is on; Battery Test Status: Last test date 13.08.15 15:29:53, Result Test finished - Canceled; Automatic Battery Test Status: Test Status Enabled, Test Interval 74 h, Inhibit time 24 h, Next Schedule time 19790 min.
- Battery Test:** Automatic Battery Test (checked), Manual Battery Test (Test Duration: 00:00:10 hr:min:sec, Min. Voltage: 0.50 V), Battery Test status (Start Battery test checked, Stop Battery Test button), Battery Test progress bar (0%).
- Battery Measurement:** Voltage 540 V, Current 256.2A, Temperature 20 °C | 68 °F, Capacity 100 %, Estimated Runtime 24 m.
- Battery Equalize:** Time: 1 hr, Voltage: 0.50 V, Start equalize, Stop equalize, Time Remaining 0 min.
- Navigation:** Status, Events log, Measures, Battery, LIFE, Settings.

Stop Battery test button

### 2.3.6 LIFE™ Menu

This menu displays the information about the Liebert LIFE Services connections, status of calls and types of calls and allows certain specific commands to be executed. This button will not active be if the LIFE Services option is not available on the UPS.

**Figure 24** LIFE menu



1. LIFE.net status		
• LIFE.net option	(Present/Not present)	Shows whether the "LIFE.net option is available on the UPS.
• LIFE.net	(Enabled/Disabled)	Shows whether the "LIFE.net option has been started.
• Current UPS date/time	dd.mm.yy hh:mm:ss	Displays the time used by the UPS to time-stamp the Life data
• 'Set Sampling Mode' button	Set samling/service mode	Toggles LIFE.net operating modes between 'service' and 'sampling'; service is used when UPS maintenance is in progress.

2. UPS calls status		
• Next scheduled call	dd.mm.yy hh:mm:ss	Displays the time of next regular UPS call.
• Emergency calls	(Enabled/Disabled)	Shows whether UPS emergency calls are enabled or have been inhibited by the Life Station for a particular reason.
• Delayed call in	dd.mm.yy hh:mm:ss	Displays the seconds countdown after which the UPS will repeat a previously unsuccessful Life communication.
• 'Reset delayed call' button	Reset delayed call	When this button is pressed, the delayed call countdown is forced to zero, so that the UPS repeats the call immediately.

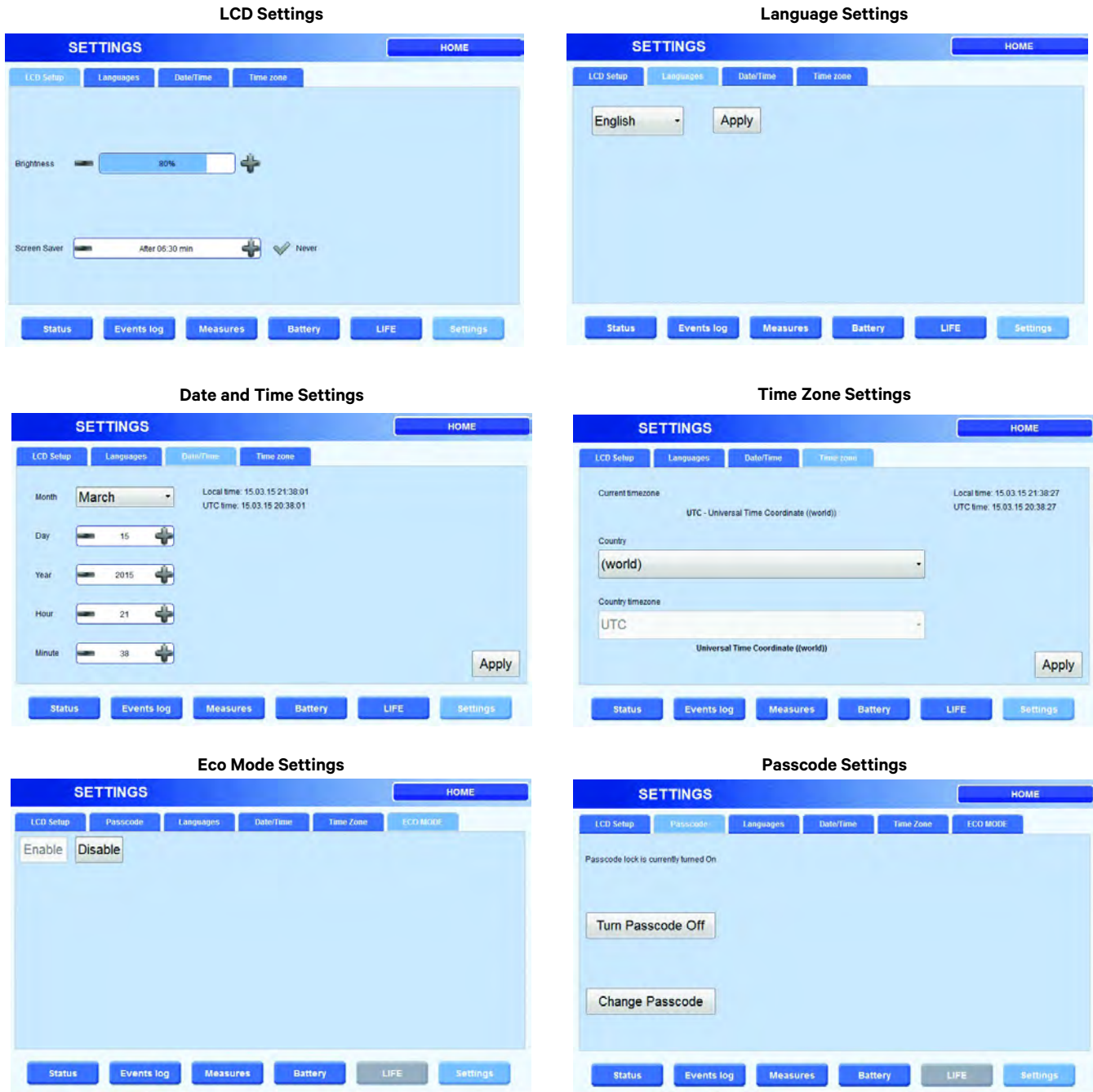
4. Call type	
• Routine call	The UPS is making its regular call.
• Emergency call	The UPS is making an Emergency call.
• Manual call	The UPS is making a Manual Call or an automatic extra call to reset an emergency condition which is no longer active.
• Buffer full call	The UPS is making a call to empty its diagnostics history buffer, which is full and cannot store any more data.
• 'Manual call request' button	When this button is pressed, the UPS is forced manually to make an immediate call to the LIFE station.

3. UPS connection status	
• Not connected	The UPS is not connected to the LIFE Station.
• Waiting for connection	The UPS has requested connection to the Life Station and is waiting for connection to be established.
• Connected	The UPS is connected to the LIFE Station.
• LIFE.net data sending in progress-stage 1	The UPS is transmitting its diagnostics history to the LIFE station.
• LIFE.net data sending in progress-stage 2	The UPS is exchanging other service data with the LIFE station.
• UPS online session in progress	The UPS has entered the online session requested by the LIFE Station Administrator, so it can be monitored in real time.
• Closing connection	The UPS is closing the connection.
• Call delayed	The UPS has scheduled a new call because the previous call failed.

### 2.3.7 Settings Menu

This menu item permits changing the LCD settings, selecting the language on the display, setting the date and time format, choosing the time zone, enabling and disabling Eco Mode and changing passcodes.

Figure 25 Settings Menus



## 2.4 ANIMATED ONE-LINE MIMIC

This displays all the functional blocks in the UPS. Touching an icon displays detailed information about the functional block. The blocks color signifies its status:

- Green: Normal
- Yellow: Warning
- Red: Fault
- Gray: Not active but no active fault

Pressing a block, such as Rectifier or Inverter, displays a page with details about the block.

### 2.4.1 Functional Blocks

This section provides details about the status of each functional block of the UPS. Touching a block displays a page with status messages and measurements as shown in **Table 2**.

**Table 2 Functional block information**

Functional Block	Measurements Displayed
Rectifier	Input Voltage L-L, Input Current phases A-B-C, Input Frequency, Input Apparent Power phases A-B-C, Temperature Sensor(s), Output Voltage, Input Supervision Counter
Bypass	Input Voltage L-L, Input Frequency, Temperature Sensor(s)
Inverter	Temperature Sensor(s) phases A-B-C
Booster/Charger	Booster Output Voltage, Charger Output Set Voltage, Charger Current Limitation, Battery Voltage, Battery Current, Temperature Sensor(s)
Battery	Voltage, Current, Temperature Sensor(s), Backup Time, Capacity (%)
Load	% Load phases A-B-C, Voltage L-L, Current phases A-B-C, Real Power per Phase (kW), Apparent Power per Phase (kVA), Frequency, Overload Time Remaining, Load %, Total Load Real & Apparent, Ambient Temperature

### 2.4.2 About Menu

This button displays the type and size of the unit. Touching this area reveals the serial number, firmware details and the IP and MAC addresses.

**Figure 26 About menu**



## 2.5 MODES OF OPERATION

This section illustrates the flow of power through circuit breakers, switches and UPS components during various modes of operation. The same modes of operation apply to all configurations of the Liebert NX. Highlighted (thick) lines in the diagrams indicate power flow and power availability. These illustrations do not show an alternate power source (generator) and automatic transfer switch (external to the UPS) that might be present. These illustrations do not show optional CB1 installed. If CB1 is installed, it is assumed to be closed.

### 2.5.1 Load on Bypass

In this operating mode, the connected loads are supplied from line power via the Static Bypass Switch. The Static Bypass Switch is used to provide power to the loads if the load has been transferred from inverter or if the power conversion systems in the UPS are in a fault condition. If a severe overload or fault occurs on the UPS output, the bypass will provide additional current for 800 milliseconds to help clear the fault. If the fault is not cleared, the UPS will transfer to bypass. The bypass operating condition is displayed. From this operating mode, the UPS automatically reverts to on-line operation after the fault is corrected. Bypass operation can also be specifically selected from the control panel using the push button.

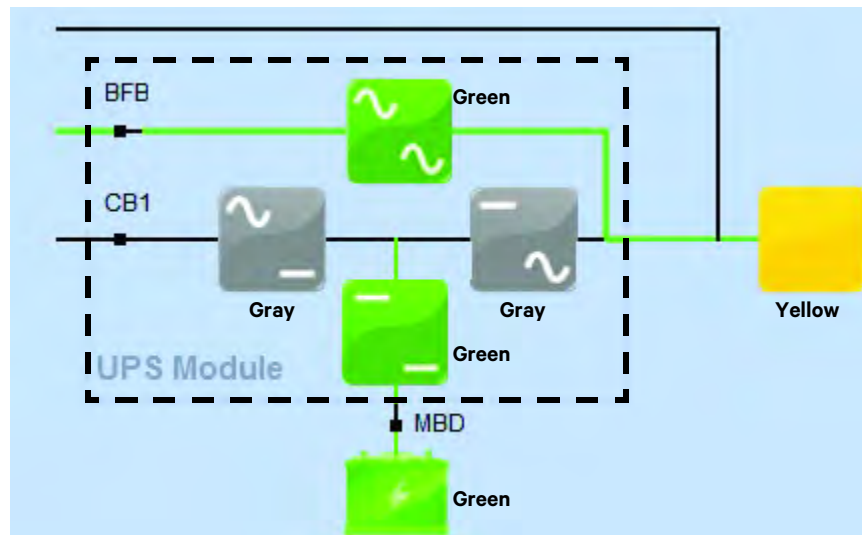
Load on Bypass is shown in **Figure 27**. The UPS system could be in this mode of operation during either initial startup or UPS system shutdown or isolation for maintenance.

#### NOTICE

Risk of unexpected power loss. Can cause equipment damage.

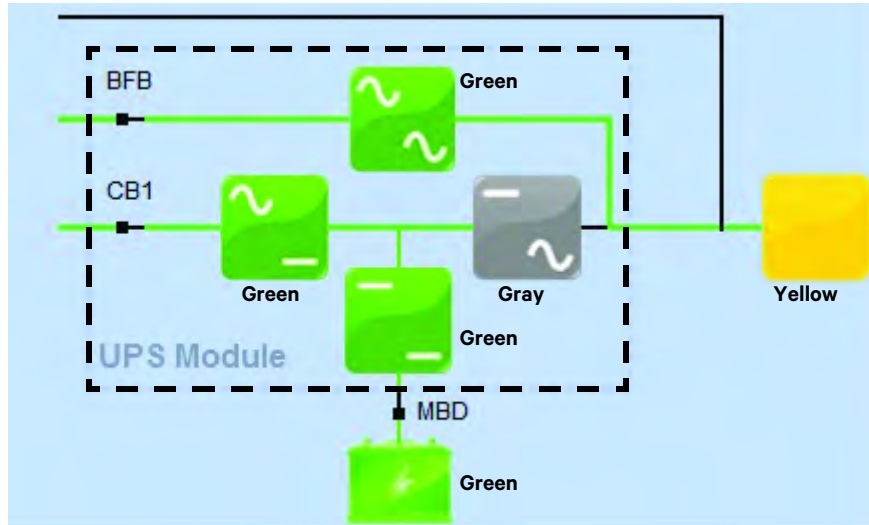
When the critical load is being supplied power from the bypass line and Eco Mode is not active, the load is vulnerable to utility failure and fluctuations.

**Figure 27** Load on bypass, UPS not operating





**Figure 28** Load on bypass, UPS available



Note that **Figure 28** illustrates the UPS in Eco Mode. The one-line mimic display appears as shown in **Figure 29**.

**Figure 29** Eco Mode one-line mimic display

## Inverter

HOME

Measurement		
Module 1 temp. sensor 1	A	20 °C   68 °F
	B	20 °C   68 °F
	C	20 °C   68 °F
Module 1 temp. sensor 2	A	20 °C   68 °F
	B	20 °C   68 °F
	C	20 °C   68 °F

Id	Name	Description
06-006	Source of Synchronization is the Output	
06-086	Operation ECO mode	Unit is operating in ECO mode
06-001	Inverter is Turning on	

Status

Events log

Measures

Battery

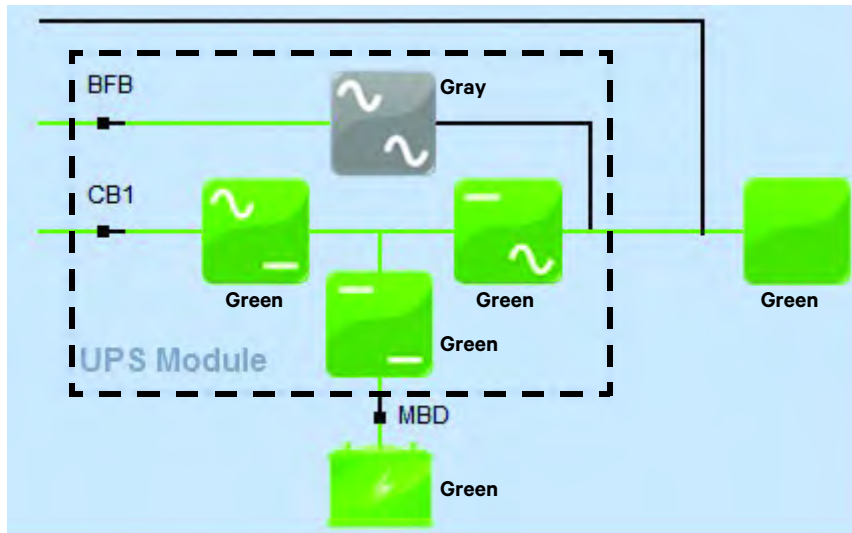
LIFE

Settings

For more information on Eco Mode, see **2.6 - Eco Mode Active**.

### 2.5.2 Normal Mode—Load on UPS

Figure 30 Load on UPS, bypass available



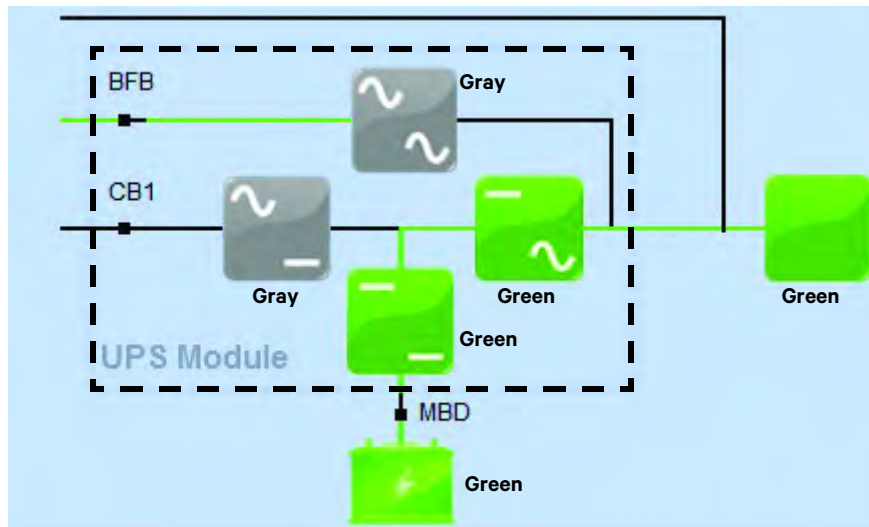
### 2.5.3 Input Power Failure—Load on DC Source

If the utility AC power source fails or is outside the acceptable range, the DC source becomes the power source for the UPS inverters. The UPS continues to supply power to the critical load and also to the UPS controls.

Use the Battery Time screen at the UPS to monitor the DC source voltage compared to the shutdown value. The time the DC source can sustain the load depends on the load's power requirements and the batteries' capacity.

The battery block in the UPS module monitor/mimic display indicates *Charge* or *Discharge* and the current in amperes.

Figure 31 Input power failure, load on DC source



### 2.5.4 Off DC Source

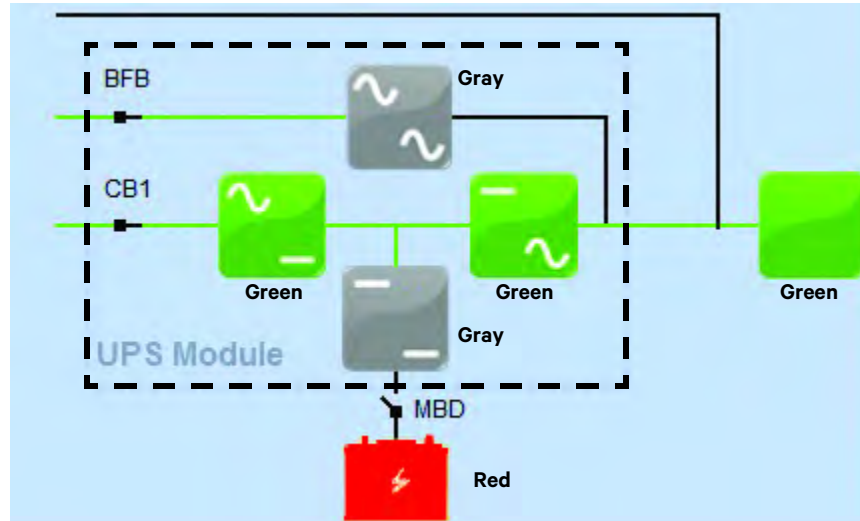
The DC source can be disconnected from the UPS, if required for maintenance, by opening all battery breakers or if single string is used, the module battery disconnect (MBD) circuit breaker. In this situation, the UPS module will continue to supply conditioned power to the critical load, but if input power fails, the UPS system cannot supply power to the load.

**NOTICE**

Risk of unexpected power loss to the connected load. Can cause equipment damage.

When the UPS is operating with all battery breakers or the module battery disconnect (MBD) circuit breaker(s) open, the critical load is not protected from loss of the utility source power.

**Figure 32 Load on UPS, DC source not available**

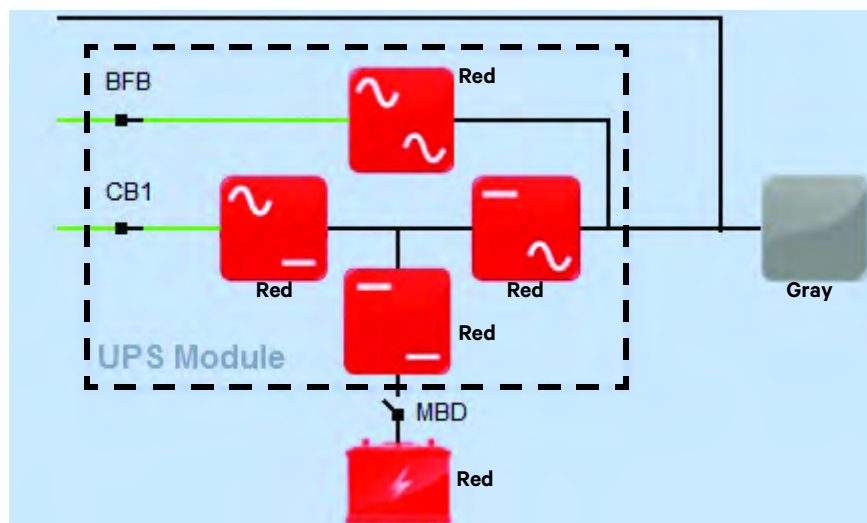


### 2.5.5 Remote Emergency Power Off

The Remote Emergency Power Off (REPO) control is a user-provided switch located remotely from the UPS system. It usually is installed in the same room as the critical load equipment. This mode can also be initiated by an automatic contact closure in the same external circuit as the manually operated switch.

When the REPO switch is operated, the UPS will shut down and open battery circuit breakers. All power through the UPS is removed from the load. In many systems, the REPO circuit also opens the circuit breakers that provide power to the bypass lines and the UPS controls. Refer to **2.7.5 - Shut Down Single Module UPS System**.

**Figure 33 Remote Emergency Power Off**



To restart a UPS module after an EPO event:

1. Verify that the original condition that required the EPO action has been corrected.
2. Verify that the system is isolated and that it is safe to restart (e.g., no personnel that could be at risk if the system is energized, etc.).
3. Follow the normal startup procedures for the system based on its configuration (single module or 1+N distributed bypass multi-module system).

## 2.6 Eco Mode Active

The UPS has determined that the bypass power quality is adequate for Eco Mode operation. The touchscreen LCD will display a message that the UPS is operating on Eco Mode. Eco Mode will be symbolized on the touchscreen LCD with a leaf symbol.



Active Eco Mode is enabled on the Liebert NX 225-600 series. The mode is incorporated in all single module systems and in multi-module (distributed bypass) units with Firmware Version 1.04 or newer. It is referred to as an Active Eco Mode because the rectifier remains On to float charge the battery and the inverter controls remain powered.

Active Eco Mode in the Liebert NX 225-600 provides performance meeting the CBEMA and ITIC curves for electronic loads, providing sufficient current to ride through the transition to and from inverter operation. However, some coordination must be considered if the system includes downstream static transfer switches that base switch decisions on voltage waveforms, because these may be distorted by an event that would cause a transfer.

### 2.6.1 Eco Mode Activation and Control

Eco Mode may be activated through the touchscreen LCD. It will be the default mode of operation until it has been deactivated.

To activate Eco Mode, navigate to the Settings menu on the touchscreen LCD and choose “Enabled.”

Eco Mode may also be inhibited through a signal to one of the programmable input contacts. This is normally set up to occur automatically if the UPS module becomes supplied by a backup or emergency input power supply, such as a generator.

### Eco Mode Adjustments

In most cases, the default tolerance settings for Eco Mode should be appropriate for correct and reliable operation. However, the limits for voltage and frequency can be adjusted by Liebert Services. Contact Liebert for more information.

### 2.6.2 Active Eco Mode

If priority has been set to Active Eco Mode, the control system will allow the Liebert NX to continuously monitor the condition of the input supply, including its failure rate, to ensure maximum reliability for critical users. That analysis determines whether the Liebert NX supplies the load through the bypass source or the conditioned line. This operational mode, which allows significant energy savings by increasing the overall AC/AC efficiency of the UPS up to 98%, is primarily intended for general purpose ICT applications. However, it does not provide the same output power quality as when the UPS operates in double conversion mode. It will therefore be necessary to verify whether this mode is appropriate for special applications.

### 2.6.3 Normal—Active Eco Mode

The operating mode will depend on the quality of the source supply in the recent past. If the line quality has remained within permitted tolerance parameters, the bypass source will provide continuous supply to the critical AC load through the bypass static switch. The IGBT inverter control system will remain in constant operation and synchronization with the bypass source without driving the IGBT's. This ensures that the load can be transferred to the conditioned line within the limits of the CBEMA and ITIC curves and IEC 62040-3: 2010 Curve 1 when there is a deviation from the selected input power tolerance levels. If the direct line failure rate has been outside permitted parameters, the Liebert NX will supply the load from the conditioned line. The battery charger supplies the energy necessary for maintaining float charge to the battery.

### 2.6.4 Inverter Stop—Active Eco Mode

If the inverter is stopped for any reason, there will be no transfer to the conditioned line and the load will continue to be supplied by the bypass source. The source voltage and frequency values must be within the tolerance limits specified.

### 2.6.5 Overload—Active Eco Mode

If an overload lasting longer than the maximum capacity specified for the bypass static switch, the load is maintained on the bypass source and a message will appear on the LCD to warn about the potential risk related to this condition. This default behavior can be changed (via a service-accessible firmware setting) to force a load transfer to the conditioned line (similar to that described below), even if the bypass source is available. In the event of an overload in conjunction with an unsuitable bypass source supply, the Liebert NX will transfer the load from the bypass source to the conditioned line (assuming that the UPS was operating from the bypass source) and the inverter will continue to supply the critical load for a period that depends on the degree of the overload and the UPS rating. Visual and audio alarms alert the user to the problem.

### 2.6.6 Emergency—Due to Source Supply Failure or Variance Beyond Tolerance Limits, Active Eco Mode

If the Liebert NX is supplying the load via the bypass source and the bypass source supply varies beyond tolerance levels (adjustable using the software), the load will be transferred from the bypass source to the conditioned line. The load is powered from the source via the rectifier and inverter, (provided the input source remains within the specified tolerances). Should the input source fall below the lower limit, the batteries will be used to power the load via the inverter. The user is alerted to the battery discharge by visual and audio alarms and the remaining autonomy is displayed on the LCD. During this process, it is possible to extend the remaining autonomy by switching off nonessential loads.

### 2.6.7 Return to Normal Conditions-Active Eco Mode

When the source supply returns to within tolerance limits, the Liebert NX will continue to supply the load via the conditioned line for a period that depends on the bypass source failure rate (the conditioned line draws power from the source, not the battery). When the bypass source has stabilized, the Liebert NX resumes powering the load from the bypass source. At this time the battery charger automatically begins to recharge the battery so that maximum autonomy is available in the shortest possible time.

## 2.7 MANUAL OPERATIONS—ALL SYSTEMS

The Liebert NX UPS is designed to function unattended by an operator. The system control logic automatically handles many important functions, as explained in **2.8 - Automatic Operations**. Other procedures must be performed manually.

Manual procedures available to the operator include startup, load transfers and shutdowns. These are performed with the touchscreen and some manually operated circuit breakers and switches.

This section lists typical step-by-step instructions.

- Startup—Including initial startup, recovering from input power failure, recovering from DC source shutdown and recovering from shutdowns for emergencies or maintenance.
- Load Transfers—Including transfers from UPS to bypass and retransfers from bypass to the UPS system.
- Maintenance Bypass Load Transfers—Including transfers from internal bypass to maintenance bypass and transfers from maintenance bypass to internal bypass.
- Shutdowns-Including module shutdowns for maintenance and emergency shutdowns.

**Figures 34** through **39** illustrate the possible maintenance bypass configurations for Liebert NX systems.

Figure 34 Maintenance bypass configurations—Two breaker

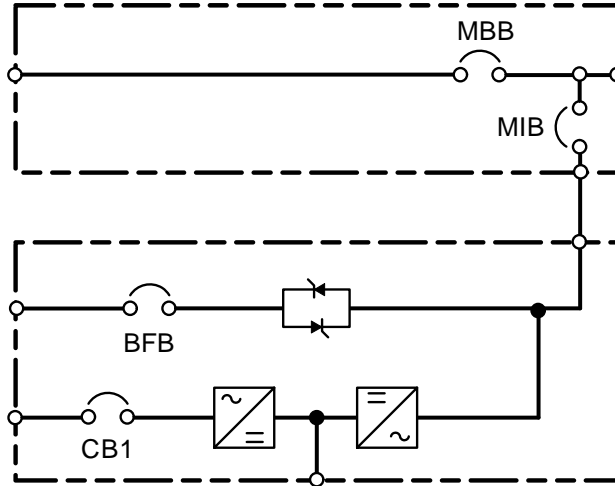


Figure 35 Maintenance bypass configurations—Three breaker for single-input UPS

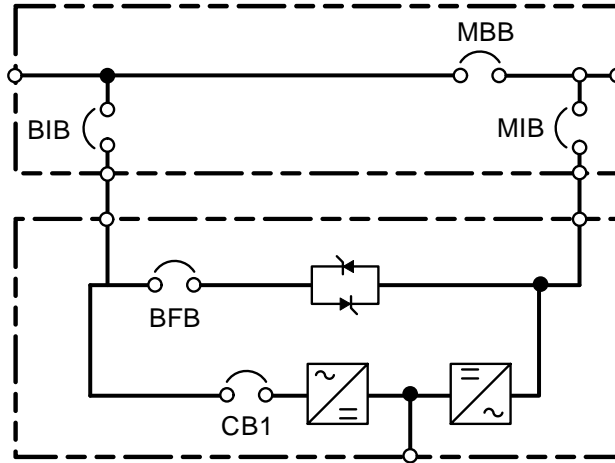
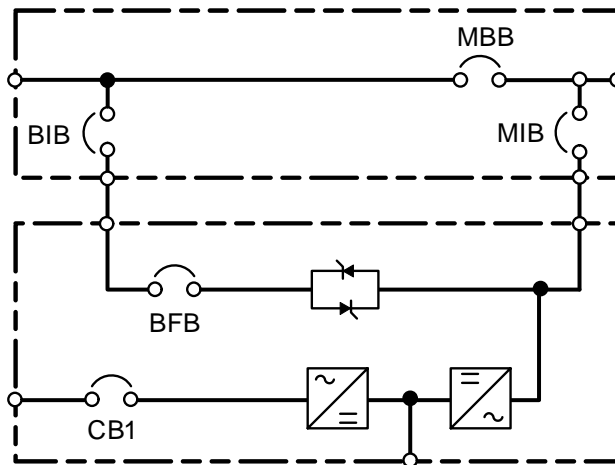
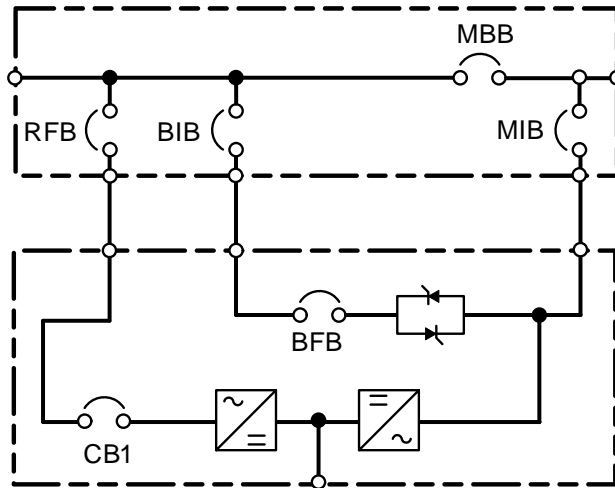


Figure 36 Maintenance bypass configurations—Three breaker for dual-input UPS



**Figure 37** Maintenance bypass configurations—Four breaker for dual-input UPS



**Figure 38** Maintenance bypass configurations—Four breaker for dual-input UPS, No CB1

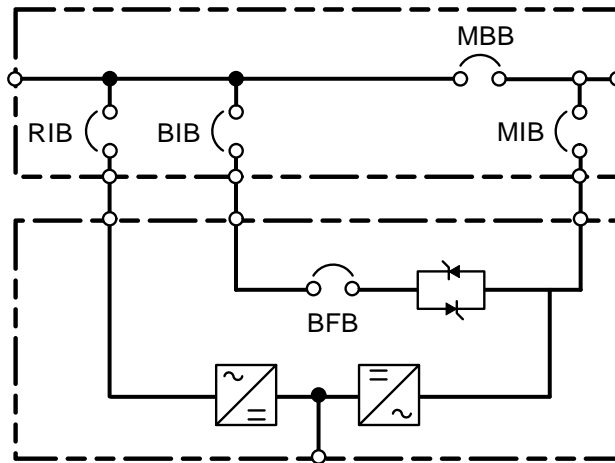
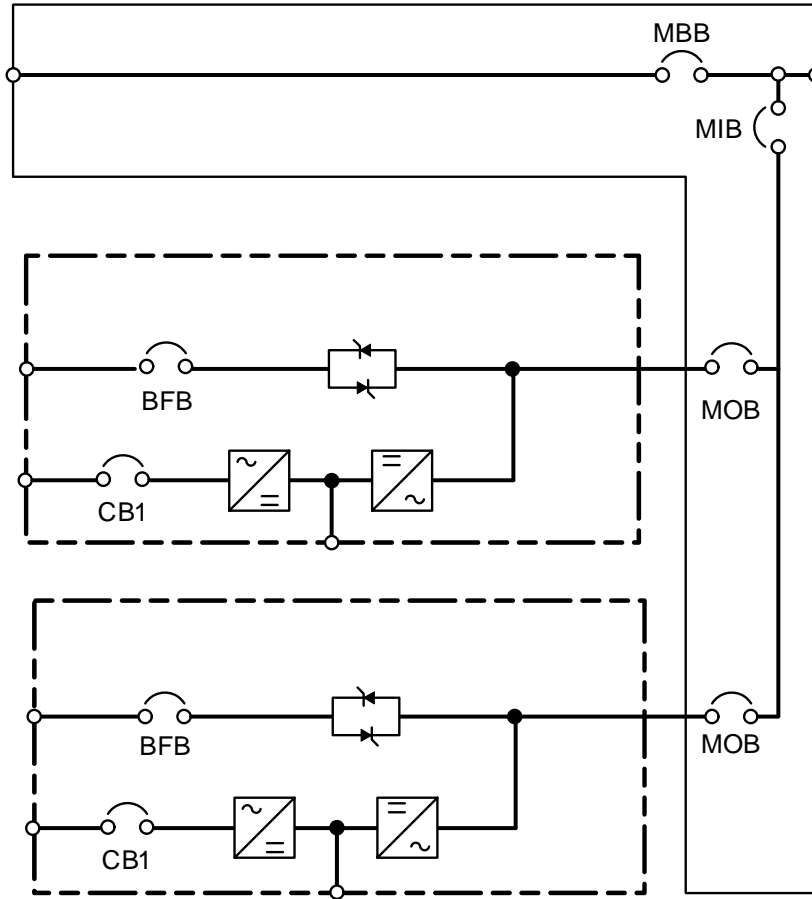


Figure 39 Maintenance bypass configurations—Distributed bypass, 1+N multi-module





## 2.7.1 Startup—Single Module System

This section lists step-by-step instructions for UPSs with maintenance bypass configurations as shown in this manual. If the system has a different maintenance bypass operation, consult the provider of that system for operating procedures. The procedure assumes that the UPS installation inspection and initial startup were previously performed by Vertiv Liebert Services™. An Vertiv-authorized representative must perform the initial system startup to ensure proper system operation.

### **WARNING**

Risk of electric shock. Can cause equipment damage, personal injury and death.

The following procedure provides power to the critical load distribution system. Verify that the critical load distribution is ready to accept power. Make sure that personnel and equipment are ready for the critical load distribution system to be energized.

### **Starting the Unit without Power Supplied to the Connected Load**

If the installation includes a Maintenance Bypass, power may already be supplied to the critical load equipment through the Maintenance Bypass. If there is no power to the critical load, apply power through the UPS bypass line per the following procedure. If the load is being supplied by Maintenance Bypass, see **Startup Single Module System from Maintenance Bypass on page 35**.

During startup, power is supplied to the load through the UPS (internal) bypass line while the UPS system is being energized. Depending on the reason for the UPS shutdown, power may be present in the bypass line. To determine this, check the monitor/mimic display screen after control power is available.



### **NOTE**

*If the system was shut down because of an Emergency Off, there may be alarm messages on the touchscreen that describe system conditions before (or at the time of) the shutdown. Some or all of the alarm conditions may have been resolved. To clear these alarm messages, turn Off control power (see **Figures 3 and 4**).*

*If the system is a multi-module system, verify that the UPS is in Maintenance bypass mode, then open the Module Output Breakers (in the distribution switchboard) because the output bus provides an additional source of control power.*

*Wait at least 10 minutes for the control power circuitry to completely de-energize. After 10 minutes, turn control power back On.*

### **WARNING**

Risk of electric shock and high short circuit current. Can cause equipment damage, injury and death.

If the UPS has been shut down for maintenance, verify that all of the UPS system doors are closed and latched. All test equipment must be removed from the system. All electrical connections must be secure.

1. Before applying power to the UPS module, determine the position of the following circuit breakers and switches:
  - Optional Input Circuit Breaker (CB1)—Verify that this breaker on the front of the UPS cabinet (see **Figures 3** and **4**) is in the open position. If this breaker is not supplied, check that the remote input breaker (RIB) (which will be external to the UPS) is open.
  - Module Battery Disconnect (MBD)—Verify that this external breaker is open or tripped. If DC source cabinets are used, verify that breakers on all the cabinets are open.
  - Bypass Backfeed Breaker (BFB)—This circuit breaker (see **Figures 3** and **4**) should be open.

**NOTICE**

Risk of improper operation. Can cause equipment damage.

If the critical load is NOT already powered through the UPS bypass, make sure that the BFB is open until instructed to close it. Failure to follow this sequence may result in equipment damage.

**NOTE**

*If power to the critical load is already supplied through this breaker, keep this breaker closed.*

2. Start the module:
  - a. Close the Rectifier Input Breaker (RIB if there is no CB1; if the UPS has a CB1, this is referred to as the RFB [Rectifier Feeder Breaker]). This breaker is external to the UPS; it may be in the Maintenance Bypass Cabinet.
  - b. Close CB1 (located in the module) if the optional input breaker is installed.

**NOTE**

*The rectifier will automatically start if there are no active faults.*

- c. Wait until the touchscreen LCD finishes booting up. This may take several minutes.
- d. Clear any faults before proceeding.

**NOTICE**

Risk of improper operation. Can cause equipment damage.

If a fault that has been cleared recurs, contact Vertiv Liebert Services™. Do not continue.

**NOTICE**

Risk of improper operation. Can cause equipment damage.

Do not close the back-feed breaker before the touchscreen LCD is fully booted up and faults are cleared.

- e. Close Bypass Backfeed Breaker (BFB).
  - The equipment mimic screen will be displayed.
  - The Static switch will turn On and the fans will be powered On.
  - The load will now be powered by the bypass.
- f. On the touchscreen LCD, verify that the Rectifier and Booster are Green.
- g. Wait until the DC bus is above 540VDC, then close all DC breakers.
  - Check the touchscreen LCD for messages and respond appropriately.
- h. Press the *Start Inverter* button on the touchscreen. Press *Confirm* on the pop-up window and the load will be energized from the UPS inverter.

**NOTICE**

Risk of improper operation. Can cause equipment damage.

If an abnormal situation occurs during this startup procedure, open the input circuit breaker and investigate the problem. Call Liebert Services if help is required.

## 2.7.2 Startup Single Module System from Maintenance Bypass

These instructions are for standard maintenance bypass cabinets that have an SKRU, MIB and MBB. If the maintenance bypass does not have all of these components, the procedures could be different. In which case, the user should locate/create specific procedures for their system.

This process includes two operations:

- Activating the UPS internal bypass to parallel the Maintenance Bypass
- Transferring the load from the bypass lines to UPS

This assumes that:

- The load is being powered by the Maintenance Bypass
- The MIB is open
- The MBB is closed
- The UPS module is Off
- The RIB is open. (This breaker will be the RIB if the UPS has no CB1; it will be the Rectifier Feeder Breaker [RFB] if the UPS has an internal CB1 input breaker.)
- CB1 (internal rectifier input breaker, if present) is open
- The BFB is open and
- The DC breakers are open.

1. Start the module:

- a. Close the Rectifier Input Breaker (RIB) or the Rectifier Feeder Breaker (RFB). This breaker is external to the UPS; it may be in the Maintenance Bypass Cabinet.
- b. Close CB1 (located in the module) if the optional input breaker is installed.
- c. Wait until the touchscreen LCD finishes booting up. This may take several minutes.
- d. Clear any faults before proceeding.

### NOTICE

Risk of improper operation. Can cause equipment damage.

If a fault that has been cleared recurs, stop immediately and contact Liebert Services. Do not continue.

### NOTICE

Risk of improper operation. Can cause equipment damage.

Do not close the back-feed breaker before the touchscreen LCD is fully booted up and faults are cleared.

- e. Close Bypass Backfeed Breaker (BFB).

The equipment mimic screen will be displayed.

The Static switch will turn On, and the fans will be powered On.

- f. On the touchscreen LCD, verify that the Rectifier and Booster are Green and that the DC bus voltage is above 540VDC.
- g. Close the MIB. (see **Step i** below if using a key interlock system)

The load will now be powered by the UPS bypass in parallel with the Maintenance Bypass.

- h. Close all DC (battery) breakers.

### NOTICE

Risk of improper operation. Can cause equipment damage.

Do not close the battery breakers until the DC bus is above 540VDC.

- i. If using a key interlock system:

1. Depress the key-release unit push button.
2. Turn the key and remove it from the key-release unit.
3. Insert the key into the lock for the Maintenance Isolation Breaker (MIB).
4. Retract the bolt.
5. Close the Maintenance Isolation Breaker (MIB).
6. Verify that the DC bus is above 540VDC.
7. Close all DC (battery) breakers.

### NOTICE

Risk of improper operation sequence. Can cause equipment damage.

Failure to close the Maintenance Isolation Breaker (MIB) will interrupt power to the load.

- j. Open the Maintenance Bypass Breaker (MBB). The load is now on UPS internal bypass.

- k. If using a key interlock system,

1. Remove the key from the lock for the Maintenance Bypass Breaker (MBB) to lock it open.
2. Reinsert the key into the solenoid.

- l. Press *Start Inverter*.

The load will be transferred to the UPS.

### 2.7.3 Load Transfer and Retransfer—Single Module System

Changing the load from the UPS inverter to the UPS bypass is called a *transfer*. Returning the load from the UPS bypass to the UPS system is called a *retransfer*. Note that the UPS system control logic can initiate automatic load transfers and retransfers. Refer to **2.8 - Automatic Operations**.

#### Transfer from UPS to Bypass Procedure

1. Press the *Stop Inverter* menu button on the touchscreen.
2. The load will transfer to Bypass mode and the Inverter will turn Off.

#### Retransfer from Bypass to UPS Procedure

1. Press the *Start Inverter* menu button on the touchscreen.
2. The Inverter will synchronize with the bypass and transfer the load to Normal mode.

### 2.7.4 Maintenance Bypass Load Transfers—Single Module System

Follow these instructions to manually transfer the load between the Maintenance Bypass and the UPS bypass line. Do not transfer the load between the Maintenance Bypass and the UPS module (inverter) output. Use the monitor/mimic display screen to verify that the UPS bypass line is available.

These instructions are for standard maintenance bypass cabinets that have an SKRU, MIB and MBB. If the maintenance bypass does not have all of these components, the procedures could be different. In which case, the user should locate or create specific procedures for the system.

#### NOTICE

Risk of improper operation. Can cause loss of power to connected load, resulting in equipment damage.  
Failing to follow the proper sequence when operating any circuit breaker may damage the connected equipment.  
Operating a Maintenance Bypass circuit breaker out of sequence could cut Off power to the critical load.  
The UPS system must be on internal bypass before the following procedures are performed or the MIB or the MBB is operated. Otherwise, the UPS may be damaged and the critical load may lose power.

#### Transfer with Load on UPS Bypass

1. Transfer the UPS system to bypass. The “OK to transfer” lamp on the key-release unit will light.
2. Press the *Stop Inverter* button on the touchscreen. The load will transfer to Bypass mode and the Inverter will turn Off.



#### NOTE

*If the maintenance bypass cabinet or switchboard has any other type of custom interlock, follow the instructions for that interlock system to remove the key.*

3. If using a key interlock system:
  - a. Depress the key-release unit push button, turn the key and remove from key-release unit.



#### NOTE

*The UPS system is now locked in bypass and cannot be retransferred to the inverter until the key is reinserted.*

- b. Insert the key into the lock for the Maintenance Bypass Breaker (MBB); retract the bolt.
4. Close the Maintenance Bypass Breaker (MBB).

#### NOTICE

Risk of improper operation sequence. Can cause loss of power to connected load, resulting in equipment damage.  
Failure to close the Maintenance Bypass Breaker (MBB) will interrupt power to the load.

5. Open the Maintenance Isolation Breaker (MIB). The UPS system is now isolated from the critical load, and the load is now on Maintenance Bypass.
6. If using a key interlock system:
  - a. Remove the key from the lock for the Maintenance Isolation Breaker (MIB).
  - b. Put the key back in the solenoid.
  - c. Open the battery breakers
7. If UPS bypass shutdown is required, open the Bypass Input Breaker (BIB). This breaker is external to the UPS; it may be in the Maintenance Bypass Cabinet.
8. Open the BFB.
9. Open CB1 (or the Rectifier Input Breaker [RIB] if the UPS is not equipped with CB1).

## Transfer with Load on Maintenance Bypass

1. Verify that the module's rectifier is On and in bypass mode. See **2.7.1 - Startup—Single Module System** for the startup sequence.
2. Close the Bypass Input Breaker (BIB) or verify that it is closed. This breaker is external to the UPS; it may be in the Maintenance Bypass Cabinet.
3. Close the UPS Backfeed Breaker (BFB). Refer to **2.7.1 - Startup—Single Module System**.
4. Close the battery breakers.
5. If using a key interlock system:
  - a. Depress the key-release unit push button.
  - b. Turn the key and remove it from the key-release unit.



### NOTE

*The UPS system is now locked in bypass and cannot be retransferred to the inverter until the key is returned.*

- c. Insert the key into the lock for the Maintenance Isolation Breaker (MIB);
  - d. Retract the bolt.
6. Close the Maintenance Isolation Breaker (MIB).

### NOTICE

Risk of improper operation sequence. Can cause equipment damage.

Failure to close the Maintenance Isolation Breaker (MIB) will interrupt power to the load.

7. Open the Maintenance Bypass Breaker (MBB). Load is now on UPS Internal Bypass.
8. If using a key interlock system,
  - a. Remove the key from the lock for the Maintenance Bypass Breaker (MBB) to lock it open.
  - b. Reinsert the key into the solenoid.
9. The UPS system may now be transferred from bypass to UPS (see **2.7.3 - Load Transfer and Retransfer—Single Module System**).

## 2.7.5 Shut Down Single Module UPS System

Perform a Module Shutdown to remove power from the UPS module.

Read all warnings in **5.0 - Maintenance** before performing any maintenance on your Liebert NX UPS. These warnings and cautions must be observed during any work on the UPS.

Use the module monitor/mimic display to determine the operating condition of the UPS module.

1. Press the *Stop Inverter* button on the touchscreen. This will put the load on bypass.
2. Open all DC breakers.
3. Open the BFB.
4. Open the bypass and rectifier breakers to complete the shutdown.

## 2.7.6 Startup—1+N Multi-Module System with Maintenance Bypass Cabinet

### **WARNING**

Risk of electric shock. Can cause equipment damage, injury or death.

This procedure will energize the critical bus. Notify all affected personnel before performing this procedure.

The UPS module(s) and the load should be de-energized at the beginning of this procedure. All circuit breakers external to the Vertiv-supplied equipment must be operated by customer personnel.

1. For initial startup, commissioning agents or authorized personnel should verify that all parallel cables are properly connected to the UPS units.
2. Close CB1 to the UPS module(s). If CB1 is not installed, skip this step.
3. Close the external rectifier and bypass feeder breakers for all modules to be started. This will start the rectifier(s). Do not proceed until the LCD is operational on all modules.
4. Verify that the rectifier of each module has started. If not, correct the issue before proceeding.
5. Verify that the DC bus is above 540VDC, then close the Module Battery Disconnect(s) (MBD's).
6. (If the back-feed breakers were closed and the load was supported through the bypass before **Step 1**, this will not be necessary; proceed with **Step 7**)—Close the Back Feed Breaker (BFB) on each UPS module.
7. Verify that the Bypass Static Switch (BPSS) becomes active when the BFB is closed.
8. Close the external Module Output Breaker (MOB) for each UPS module.
9. Verify the UPS status on the mimic screen. The load should be on the UPS bypass.
10. Close the Maintenance Isolation Breaker (MIB). If a maintenance bypass interlocking scheme is available, then proceed with the operation of the interlock until the MIB is closed and the MBB is opened.
11. Place the collector bus on inverter:
  - a. Starting with Module 1, select the *Start Inverter* icon on the user mimic screen.
  - b. Verify that the screen says *Inverter on pending command* for the inverter status.
  - c. Repeat **Steps a** and **b** for all modules. Each module will activate its inverter and turn Off the Bypass Static Switch (BPSS) after *Start Inverter* is selected on the last UPS module.

## 2.7.7 Transfer the Load from UPS to Bypass: 1+N System

These instructions are for standard maintenance bypass cabinets that have an SKRU, MIB, and MBB. If the maintenance bypass does not have all of these components, the procedures could be different. In which case, the user should locate/create specific procedures for their system.

1. Press the *Stop Inverter* button on each module's touchscreen. This will transfer the UPS system to bypass.



### NOTE

*The inverters will stay online until the Stop inverter button is pressed on the last module if all modules accepted the STOP INVERTER command.*

2. If transferring to a wrap-around Maintenance Bypass
  - a. If using a key interlock system:
    1. The *OK to transfer* lamp on the key-release unit will light.
    2. Depress the key-release unit push button.
    3. Turn the key and remove it from the key-release unit.
    4. Insert the key into the lock for the Maintenance Bypass Breaker (MBB).
    5. Retract the bolt.
  - b. Close the Maintenance Bypass Breaker (MBB).
  - c. Open the Maintenance Isolation Breaker (MIB). The UPS system is now isolated from the critical load and the load is now on Maintenance Bypass.
  - d. Open the Battery Breakers.
  - e. If using a key interlock system:
    1. Remove the key from the lock for the Maintenance Isolation Breaker (MIB).
    2. Reinsert the key into the solenoid.
    3. Open the MOB to all modules.
    4. Open the BFB for all modules.
    5. Open the RIB (or RFB), CB1 and BIB for all modules.

## 2.7.8 Transfer Load from Bypass to UPS: 1+N Distributed Bypass System

These instructions are for typical switchboard configurations that have an SKRU, MIB and MBB, plus an RIB or RFB and MOB for each UPS module. If the switchboard configuration does not have all of these components, the procedures could be different. In which case, the user should locate/create specific procedures for the system.

1. Verify that each module's rectifier is On and in bypass mode. See **2.7.6 - Startup—1+N Multi-Module System with Maintenance Bypass Cabinet** for the startup sequence.
2. For every module in the system, close the Module Output Breaker (MOB) or verify that it is closed. This breaker is external to the UPS; it may be in the Maintenance Bypass Cabinet.
3. Close the battery breaker for each module in the system.
4. If transferring from a wrap-around Maintenance Bypass
  - a. If using a key interlock system,
    1. Depress the key-release unit push button.
    2. Turn the key and remove it from the key-release unit.
    3. Insert the key into the lock for the Maintenance Isolation Breaker (MIB).
    4. Retract the bolt.
  - b. Close the Maintenance Isolation Breaker (MIB).
  - c. Open the Maintenance Bypass Breaker (MBB). Load is now on UPS Internal Bypass.
  - d. If using a key interlock system,
    1. Remove the key from the lock for the Maintenance Bypass Breaker (MBB) to lock it open.
    2. Reinsert the key into the solenoid.
5. Select the *Start Inverter* icon on the touchscreen LCD of Module 1. Vertiv recommends starting with Module 1 and continuing in order when instructed to do so.
6. Verify that *Inverter pending on command* message is displayed in the Inverter section of the Status screen.
7. Repeat **Steps 5** and **6** for the remaining modules.



### NOTE

*After the Start Inverter icon on the last module has been selected, all inverters will turn On simultaneously.*

## 2.7.9 Load Transfer-1+N System—Remove One UPS Module from System (Collective)

### NOTICE

Risk of loss of power to the critical load. Can cause equipment damage.

If a UPS module is removed from the collector bus, the remaining modules MUST remain on inverter. Otherwise, if the offline module control power is cycled (turned Off and then On) while the bypass line(s) of the remaining UPS module(s) are connected to the collector bus, the output bus will be dropped. This will remove power from the connected load.

1. Verify that enough modules are online to support the load before proceeding.
2. Open the MOB breaker of the module to be removed.
3. Open the module battery disconnects of the module that has been removed from service.
4. Open the Backfeed Breaker (BFB) of the module that has been removed from service.
5. Open the upstream feeder breakers supplying the UPS rectifier and the bypass. (The rectifier will turn Off at this time).

## 2.7.10 Load Transfer-1+N System—Add One UPS Module to the System (Collective)

(Re-energize [Turn On] a partially de-energized 1+N system—Adding a module to the collector bus.) The inverters of the UPSs connected to the collector bus must be active before this procedure is begun.

### NOTICE

Risk of loss of power to the critical load. Can cause equipment damage.

A load drop will occur if the UPS modules supporting the load are in Bypass Mode and control power is applied to the offline module (assuming that paralleling cables are installed in the offline module when control power is turned On).

Paralleling cable connections should be verified by the commissioning agent or other authorized personnel.

1. Verify that all parallel cables are properly connected to the UPS units.
2. Verify that the Bypass Backfeed Breaker (BFB) is open.

### NOTICE

Risk of improper operation sequence. Can cause equipment damage.

Failure to have the BFB open until directed to close it may result in equipment damage.

3. Close CB1 to the UPS module. If CB1 is not installed, skip this step.
4. Close the external rectifier and bypass feeder breakers.



### NOTE

*The rectifier will start at this time. Do not proceed until the user LCD is operational. Clear any faults before proceeding. Do not continue if the UPS is displaying an Output Voltage Out Of Tolerance fault. Contact Vertiv Liebert Services™.*

5. Verify that the rectifier has started. If not, correct the issue before proceeding.
6. Close the Back Feed Breaker (BFB). The Bypass Static Switch (BPSS) should not activate.
7. Verify that the DC bus is above 540VDC, then close the Module Battery Disconnect(s) (MBD's)
8. Use the UPS status on the mimic screen to verify that the rectifier is On and the BPSS is not active. Do not proceed if the BPSS is active. Correct the issue before proceeding.
9. Close the MOB. The inverter should automatically start after a short period of time. If the inverter does not start, then select the Start Inverter icon from the user mimic screen to add the inverter to the collector bus.
11. Verify that all inverters are connected to the collector bus and operating properly.

## 2.7.11 De-Energize 1+N System With Maintenance Bypass Cabinet

This procedure assumes that the inverters are supporting the load.

1. Place the collector bus on bypass:
  - a. Starting with Module 1, select the *Stop Inverter* icon on the user mimic screen.
  - b. Verify that the inverter status is *Inverter off pending command*.
  - c. Repeat **Steps a** and **b** for all modules. Each module will activate its Bypass Static Switch (BPSS) and turn Off its inverter after the *Stop Inverter* is selected on the last UPS module.
2. Verify that the load is on bypass power.
3. Close the Maintenance Bypass Breaker (MBB). If a maintenance bypass interlocking scheme is available, proceed with the operation of the interlock until the MBB is closed and the Maintenance Isolation Breaker (MIB) is opened.
4. Open the external Module Output Breaker (MOB) on each UPS module. The inverters will not turn Off until All modules have accepted the instruction.



## NOTICE

Risk of improper operation. Can cause overheating resulting in equipment damage.

Complete **Steps 5** through **7** as quickly as possible. The steps above will cause the fans to stop. Leaving the UPS in this mode for long may cause the rectifiers to overheat and shut down.

5. Open the Module Battery Disconnect (MBD) on each UPS module.
6. Open the Back Feed Breaker (BFB) on each UPS module.
7. Open the upstream feeds to the UPS rectifier and bypass buses. This will shut Off the rectifier.

## 2.8 AUTOMATIC OPERATIONS

The Liebert NX UPS is designed to function unattended by an operator. The system control logic monitors the performance of the UPS, the availability of power sources and the current required by the critical load.

The system control logic:

- Determines what overload conditions can be sustained without a transfer to bypass.
- Initiates an automatic transfer to bypass to sustain an overload or when selected UPS faults occur.
- Can initiate an automatic retransfer to the UPS after an overload has been cleared.
- Initiates an automatic transfer to bypass and emergency module shutdown when specified UPS faults occur.

The Overload Transfer and Output Undervoltage alarm messages will initiate an automatic transfer to bypass. Other UPS faults will initiate an automatic transfer to bypass followed immediately by the shutdown and isolation of the UPS.

If a manual transfer is required and the UPS is not synchronized to the bypass, there may be a delay ranging from 4 milliseconds to 120 milliseconds (adjustable by Liebert Services) before the transfer is complete.



### NOTE

*A load transfer to the bypass line will be completed whenever an automatic transfer to bypass is initiated and the bypass line is available. If the OK to Transfer condition is present, the load transfer will be uninterrupted. If the status message saying Source of synchronization is the self-clock or Source of synchronization is the bypass is present, the automatic transfer will be interrupted for 4 to 120 milliseconds (default is 16 milliseconds). The reliability of the UPS components makes an interrupted load transfer unlikely.*

### 2.8.1 Overloads (Without Transfer)



### NOTE

*A load transfer to the bypass line will be completed whenever an automatic transfer to bypass is initiated. If the message Source of Synchronization is the Bypass is present, the load transfer will be uninterrupted.*

*If a status message saying Source of synchronization is the self-clock or Source of synchronization is the bypass is present, the automatic transfer will be interrupted for 4 to 120 milliseconds. The reliability of the UPS components makes an interrupted load transfer unlikely.*

The UPS is capable of sustaining full output voltage ( $\pm 2\%$  of the nominal voltage) for overload conditions that remain within (under) the current-versus-time curve of overload capacity (**Table 3**).

Note that the time scale is not linear.

For high current demands of short duration (momentary overloads), the critical load is supplied simultaneously by both the UPS system and the bypass line. Whenever an overload condition occurs, you should determine the cause of the overload. If an overload condition exceeds the overload capacity, the UPS system initiates an automatic load transfer to the bypass line.

For overloads above the Input Current Limit, a DC source, such as a battery system or a generation source, must be available. The Input Current limit has a default setting of 125% rated output current.

**Table 3 Current-versus-time curves of overload capacity**

Load (%)	Overload Time, sec. (min.)				
	104°F (40°C)	95°F (35°C)	86°F (30°C)	77°F (25°C)	60°F (20°C)
101	8249.9 (137.5)	10,999.8 (183.3)	13,749.8 (229.2)	16,499.7 (275)	16,499.7 (275)
105	1650.0 (27.5)	2200.0 (36.7)	2750.0 (45.8)	3299.9 (55)	3299.9 (55)
110	825.0 (13.75)	1100.0 (18.3)	1375.0 (22.9)	1650.0 (27.5)	1650.0 (27.5)
115	550.0 (9.2)	733.3 (12.2)	916.7 (15.3)	1100.0 (18.3)	1100.0 (18.3)
120	412.5 (6.9)	550.0 (9.2)	687.5 (11.5)	825.0 (13.8)	825.0 (13.8)
125	319.4 (5.3)	425.9 (7)	532.4 (8.9)	638.9 (10.6)	638.9 (10.6)
130	222.2 (3.7)	296.3 (4.9)	370.3 (6.2)	444.4 (7.4)	444.4 (7.4)
135	152.7 (2.5)	203.6 (3.4)	254.6 (4.2)	305.5 (5)	305.5 (5)
140	100.6 (1.7)	134.2 (2.2)	167.7 (2.8)	201.3 (3.4)	201.3 (3.4)
145	36.7 (—)	48.9 (—)	61.1 (1.0)	73.3 (1.2)	73.3 (1.2)
150	27.7 (—)	37.0 (—)	46.2 (—)	55.4 (—)	55.4 (—)
155	7.3 (—)	9.7 (—)	12.1 (—)	14.6 (—)	14.6 (—)
160	7.3 (—)	9.7 (—)	12.1 (—)	14.5 (—)	14.5 (—)
165	7.3 (—)	9.7 (—)	12.1 (—)	14.5 (—)	14.5 (—)

The inverter overload is based on 104°F (40°C) ambient. At lower ambient temperatures, the overload timers automatically adjust to longer run times.

**2.8.2 Automatic Transfers to Bypass (Overload Condition)**

The UPS will initiate an automatic load transfer to the bypass line if an overload exceeds the current-versus-time curve of overload. If the UPS module shuts down due to an overload, the module will restart and automatically retransfer once the load is reduced to 100% or less. Vertiv Liebert Services™ can program other thresholds, such as 95%, if desired.

**2.8.3 Automatic Transfers to Bypass, UPS System Faults**

For specified UPS system faults, the control logic will initiate an automatic transfer to bypass followed immediately by a shutdown and isolation of the UPS. The DC source (MBD) and input circuit breakers are open. The bypass static switch will be closed if the bypass line is available.



**NOTE**

*The bypass line is usually not available during Low-Battery Shutdown.*

The following UPS system faults will initiate an automatic transfer to bypass:

- DC Overvoltage Shutdown
- Inverter Fault
- Low-Battery Shutdown
- Output Overvoltage and Undervoltage
- Overload Shutdown
- Equipment Overtemperature
- Rectifier Fuse Blown

Some installations may include a Remote Emergency Power Off mode that can be initiated automatically by a contact closure in the critical load equipment. Refer to **2.5.5 - Remote Emergency Power Off**.

## 2.8.4 Automatic Retransfers to UPS

The following critical bus conditions must be present to initiate an automatic retransfer of the critical load from the bypass source to the UPS inverter:

- Critical load was initially transferred to the bypass source due to a system overload only. A manual retransfer from bypass is required if the transfer to bypass was caused by any condition other than output overload.
- Overload has since dropped below 100% of the rated load.
- Both the input and the DC source (MBD) circuit breakers have remained closed since the overload transfer.
- *OK to Transfer* signal received from the control logic for at least 10 seconds, within 5 minutes of the system overload transfer. A manual retransfer from bypass is required for overloads lasting 5 minutes or more.
- Cyclic-type overloads, which occur up to five (range is zero to five) times in 60 minutes, are automatically returned to the inverter for each event including the Nth overload.



### NOTE

*The UPS can be set during initial commission to prevent automatic retransfers. Liebert Services can alter the UPS later to prevent automatic retransfers.*

## 3.0 UPS MESSAGES: STATUS, WARNING, FAULT

The Liebert NX 225-600 generates three types of messages based on the severity of the condition. The severity of the message will be indicated in the display.

- Status—The system is operating normally and no warning or alarm has occurred.
- Warning—Abnormal conditions exist that could affect the normal operation of the UPS. These conditions do not originate with the UPS, but may be caused either by the surrounding environment or by the electrical installation (line power side and load side).
- Fault—Immediate attention should be given to the severity of the alarm, and service should be called promptly.

Each message has a message ID number, which is displayed in the first column of the display screen. When contacting Vertiv for support regarding a message, refer to this message ID number.

**Table 4** UPS status, warning and fault messages

Message ID #	Message Type/Severity	Name	Description
0	Status	The CPU is Overloaded	
0	Status	The RAM Used is Very High	
0	Status	Parameter Read Failed	A parameter could not be read from the DIC
0	Status	Parameter Set Failed	A parameter could not be written to the DIC
00-000	Status	Warning Pending	A warning condition has been detected.
00-001	Status	Fault pending	A fault condition has been detected.
00-002	Status	General fault	
00-003	Status	Parallel Unit	This unit is part of a parallel installation
00-004	Status	ECO mode enabled	Unit is configured to operate in ECO mode
00-005	Status	External Synchronization Enabled	The possibility to synchronize externally this unit is enabled
00-006	Status	Inverter or Rectifier OFF Command Issued	An inverter or rectifier off command has been issued (via display or via client)
00-007	Status	Shutdown Pending	The UPS is going to shutdown
00-009	Status	Inverter on Rectifier	The inverter is supplied by the rectifier
00-010	Status	Inverter on Battery	The inverter is supplied by the battery
00-011	Status	Parameter Reset Active	A Parameter reset has been done; check and confirm all settings
00-023	Status	System Power UP	The system is currently starting
00-034	Status	CPU Time Slice Exceeded	
00-130	Status	CAN Timeout	DSP Status word not received for more than 2 min
00-131	Status	SKRU: Inverter start Inhibited	Inverter Start inhibited by SKRU Unit key
01-000	Status	Bypass is not Present	
01-001	Status	Bypass is on	
01-002	Status	Bypass is Off	
01-003	Status	Bypass Stopped Due to Fault	
01-004	Status	Bypass not Prepared	
01-005	Status	Bypass Fault	
01-006	Status	Bypass Mains is out of Tolerance	
01-007	Status	Bypass Warning	
01-008	Status	Bypass Available with Delay	
01-029	Status	Parallel Bypass OK	
01-030	Status	Parallel Bypass one Fault	

**Table 4** UPS status, warning and fault messages (continued)

Message ID #	Message Type/Severity	Name	Description
01-031	Status	Parallel bypass at Least one OK	
01-032	Status	Parallel Bypass Fault	
01-033	Status	Parallel Bypass Failure	The parallel bypass has a failure
02-000	Status	Rectifier is off	
02-001	Status	Rectifier is Turning on	
02-002	Status	Rectifier is on	
02-004	Status	Rectifier Fault	
02-005	Status	Rectifier Mains is out of Tolerance	
02-006	Status	No Precharge in Progress	
02-007	—	—	
02-008	—	—	
02-009	Status	Rectifier Warning	
02-011	Status	Precharge in Progress	
02-012	Status	Walk-in in Progress	
02-013	Status	Precharge Finished	
03-000	Status	Charger is on standby - (not charging)	
03-001	Status	Charger is on	
03-002	Status	Charger is off	
03-003	Status	Charger is Forced to Charge	
03-005	Status	Charger Warning	
03-006	Status	Charger Fault	
04-000	Status	Battery Warning	
04-001	Status	Battery Fault	
04-002	Status	Battery Idle	
04-006	Status	One/several Battery Breaker(s) is/are open	
04-007	Status	A Battery Conditioning is in Progress	
04-032	Status	Automatic Battery Test Started	
04-033	Status	Battery Test Requested	A battery test start has been requested
04-035	Status	Battery Test Failed	
04-048	Status	Battery Test Idle	
04-049	Status	MUN Synchronization Done	
05-000	Status	Booster is off	
05-001	Status	Booster is Turning on	
05-002	Status	Booster is on	
05-003	Status	Booster Stopped Due to Fault	
05-004	Status	Booster Fault	
05-005	Status	Booster Warning	
05-018	Status	Booster Runs from Battery	The Booster/Charger is taking energy out of the battery
06-000	Status	Inverter is off	
06-001	Status	Inverter is Turning on	
06-002	Status	Inverter is on	
06-003	Status	Inverter Stopped Due to Fault	

**Table 4 UPS status, warning and fault messages (continued)**

Message ID #	Message Type/Severity	Name	Description
06-004	Status	Inverter Fault	
06-005	Status	Source of Synchronization is the Bypass	
06-006	Status	Source of Synchronization is the Output	
06-007	Status	Source of Synchronization is the Self Clock	
06-008	Status	Source of Synchronization is External	
06-010	Status	Inverter Warning	
06-011	Status	Inverter out of Synchronization	Inverter out of synchronization with internal Bypass
06-012	Status	Battery Test Idle	
06-013	Status	Battery Test Not Possible	
06-014	Status	Battery Test running	
06-015	Status	Battery Test Failed	
06-016	Status	Inverter out of Synchronization	Inverter out of synchronization with external source
06-086	Status	Operation: ECO mode	Unit is operating in ECO mode
07-000	Status	Load Supplied by Inverter	
07-001	Status	Load Supplied by Bypass	
07-002	Status	Load Supplied by Maintenance Bypass	
07-003	Status	Load is currently not supplied	
07-004	Status	Load on Low Priority Line	
07-005	Status	Load on Phase A > 85%	
07-006	Status	Load on Phase B > 85%	
07-007	Status	Load on Phase C > 85%	
07-008	Status	Load warning	
08-000	Status	MUN Warning	
08-001	Status	MUN has a Fault	
08-003	Status	UPS Model Detection in Progress	
08-004	Status	MUN Initialization Finished	
08-005	Status	MUN Reboot Required	MUN initialization finished, but a reboot is required
08-006	Status	Set UPS Date and Time	
08-011	Status	System Started	
08-013	Status	E.P.O.	The emergency power off has been activated
08-025	Status	Acknowledge Button has been Pressed	
08-026	Status	The UPS Clock Time is not Valid	
08-027	Status	The UPS Clock has not been set yet	
08-029	—	—	
08-030	Status	Event Log Deleted Due to Data Corruption	
08-031	Status	Temporary Event Log Deleted due to Data Corruption	
08-032	Status	A File was Removed Due to Data Corruption	
08-033	Status	Life Call in Progress	LIFE is calling the life station

**Table 4 UPS status, warning and fault messages (continued)**

Message ID #	Message Type/Severity	Name	Description
08-034	Status	Life Call Rescheduled	Last LIFE call was unsuccessful and is rescheduled
08-035	Status	Life Modem not Detected	Check internal Modem or external Modem cabling and power supply
14-003	Status	Battery is Charging	
14-008	Status	Battery Test in Progress	A battery test is in progress
14-018	Status	Battery Autonomy Test Running	
14-034	Status	Battery Test Running	
14-036	Status	Battery Test Not Allowed	Test is not possible
14-037	Status	Battery Test Finished OK	
14-038	Status	Battery Test Canceled	
14-050	Status	Battery Test Interrupted	
14-051	Status	Battery Test Stopped by User	
16-029	Status	Inverter Pending on Command	
20-018	Warning	Commissioning / Test Mode	The commissioning or test mode is currently initiated
20-019	Warning	Maintenance Bypass	The unit maintenance bypass switch is currently closed
20-022	Warning	Synchronization System Fault	The external synchronization signal is outside acceptable window
20-024	Warning	System Shutdown	A system shutdown is imminent
20-025	Warning	The ID Card is Missing	Please insert the ID card
20-026	Warning	Calibration is Started	
20-027	Warning	Input Air Temperature High	Check Air Flow and Fans
20-028	Warning	Input Air Temp. out of Range	Check Sensors
20-029	—	—	—
20-031	Warning	SBS Output Switch open	The system output switch is open
20-032	Warning	SBS Bypass Switch closed	The system bypass switch is closed
20-127	—	—	—
20-132	Warning	BIB Communication	Communication with BIB boards failed or BIB configuration mismatch
20-133	Warning	Ground Fault	Ground Fault
21-012	Warning	Bypass Input Switch Open	
21-013	Warning	Bypass Mains Failure	
21-014	Warning	Bypass Overload	
21-016	Warning	Bypass Disabled	Bypass disabled due to DC Bus low voltage
21-017	Warning	Bypass Overtemperature	Bypass reports overtemperature
21-018	Warning	Bypass Mode not Auto	Bypass mode is not set to automatic
21-037	Warning	Bypass Input Fuse Blown	
21-038	Warning	Parallel Bypass Failure	
22-014	Warning	Rectifier Input Switch Open	
22-015	Warning	Rectifier Mains Failure	
22-016	Warning	Rectifier Overload	
22-017	Warning	Wrong Phase Rotation	
22-018	Warning	DC Voltage Low	
22-019	Warning	Rectifier Overtemperature	

**Table 4 UPS status, warning and fault messages (continued)**

Message ID #	Message Type/Severity	Name	Description
22-020	Warning	Rectifier Out of Synchronization	Rectifier is temporarily stopped
22-021	Warning	Peak in Input Voltage	
22-022	Warning	Input Current Reached Limit	
22-044	Warning	Rectifier Input Fuse Broken	
23-007	Warning	Communication to charger is Perturbed	
23-008	Warning	Charger Actual Values Differ from set Values	
23-010	Warning	Charger is on, but Voltage Does Not Raise	Bad battery or defective charger
23-011	Warning	Charger is off, but Voltage does not Raise	Bad battery or defective charger
23-012	Warning	There is no Battery Connected to the Charger	
23-013	Warning	Charger Forced on but Voltage does not Raise	
23-014	Warning	Reversed Polarity	Check the battery connection to the charger
24-004	Warning	Battery is Discharging	
24-010	Warning	Battery Lifetime Exceeded	The battery should be replaced
24-012	Warning	Battery Undervoltage	
24-014	Warning	Battery Test Recommended	It is recommended to verify the battery performance with a battery test
24-015	Warning	High Battery Temperature	
24-016	Warning	Battery Temperature out of Range	The battery temperature is out of limit
24-017	Warning	Battery Temperature Probe	The temperature probe is not connected or broken
24-039	Warning	Battery #1 is Open	The designated battery circuit breaker is open
24-040	Warning	Battery #2 is Open	The designated battery circuit breaker is open
24-041	Warning	Battery #3 is Open	The designated battery circuit breaker is open
24-042	Warning	Battery #4 is Open	The designated battery circuit breaker is open
24-043	Warning	Battery #5 is Open	The designated battery circuit breaker is open
24-044	Warning	Battery #6 is Open	The designated battery circuit breaker is open
24-045	Warning	Battery #7 is Open	The designated battery circuit breaker is open
24-046	Warning	Battery #8 is Open	The designated battery circuit breaker is open
24-047	Warning	Battery #9 is Open	The designated battery circuit breaker is open
25-006	Warning	Booster Min Voltage	The minimal voltage to switch on the booster has not been reached
25-007	Warning	Booster/Charger Overtemperature	The Booster/Charger reports an overtemperature
26-024	Warning	Inverter Overtemperature	
26-025	Warning	Inverter DC Undervoltage	
26-026	Warning	Inverter Overload	
26-027	Warning	Inverter is off	
26-028	Warning	Inverter Pending Off Command	
26-030	Warning	Inverter Overload	Current limitation is active
26-031	Warning	Inverter Overload	KW Protection
26-032	Warning	The Inverter is Off ...	... due to a shutdown command
27-009	Warning	Output Switch is Open	



**Table 4 UPS status, warning and fault messages (continued)**

Message ID #	Message Type/Severity	Name	Description
27-010	Warning	Load is Currently not Supplied	
27-011	Warning	Retransfer is Inhibited	
27-012	Warning	Load is Supplied by the Bypass	
27-013	Warning	Load is Supplied by the Maintenance Bypass	
27-020	Warning	Load Not Supplied (for Countdown Timer)	
27-023	Warning	System Output Switch Open	
27-024	Warning	Load not Supplied for Battery Autonomy End	
27-025	Warning	Load not supplied for Inverter Autonomy End	
28-008	Warning	CAN Communication Disturbed	
28-056	Warning	UPS Model Cannot be Identified	Check CAN communication and the system settings
30-020	Fault	Fan Life Exceeded	The expected fan life is exceeded - The fan should be replaced during the next maintenance visit
30-033	Fault	Battery Switch Close not Allowed	Do not close the battery switch, check DC bus voltage
30-036	Fault	Incorrect Power Class	The power class from this unit needs to be specified
30-038	Fault	Bypass Illegal Software Status	Bypass illegal software status
30-039	Fault	Rectifier Illegal Software Status	Rectifier illegal software status
30-040	Fault	Inverter Illegal Software State	
30-049	Fault	CCB Signal Hardware Failure	The CCB signal board needs to be replaced
30-053	Fault	DSAVE Active	DSAVE Signal Active
30-054	Fault	Checksum Fault	EEPROM checksum fault
30-055	Fault	I2C Initialization	I2C Initialization Failed
30-056	Fault	I2C I/O expander	I2C Multiple Error I/O expander
30-057	Fault	ID-Card Access	ID-card access error
30-059	Fault	Ambient Temperature Probe	The input air temperature probe has a malfunction
30-071	Fault	Parallel Cable Missing	Parallel cable fitted signal missing
30-072	Fault	Main State Machine Error	Incorrect state in main state machine
30-073	Fault	State Machine Error	Incorrect state in State machine
30-074	Fault	Generic Error	Generic Software Error
30-075	Fault	ID-Card Error	Generic Error in ID-Card
30-076	Fault	RAM Error	Insufficient RAM in ID-card
30-077	Fault	Parameter Init	Bootstrap initialization of parameters called at runtime
30-078	Fault	Parallel Timeout	Parallel node identification timeout
30-079	Fault	Parallel Identification	Parallel node identification error
30-080	Fault	Parallel Impossible	Parallel node identification not possible
30-134	Fault	Battery Overvoltage EPO	Battery overvoltage emergency power off
31-015	Fault	Wrong Phase Rotation	
31-020	Fault	E.P.O.	
31-021	Fault	Bypass Hardware Failure	The bypass board needs to be replaced
31-022	Fault	Bypass Hardware Failure	
31-023	Fault	Backfeed Protection	Investigate the cause of the backfeed and reset the fault

**Table 4 UPS status, warning and fault messages (continued)**

Message ID #	Message Type/Severity	Name	Description
31-024	Fault	Overtemperature	Verify if fans are working properly and reset the fault
31-026	Fault	Overload	Investigate the cause of the overload condition and reset the fault
31-027	Fault	Bypass Mains Failure During Dynamic Support	
31-028	Fault	Parallel Bypass Mains Failure During Dynamic Support	
31-035	Fault	Overtemperature	
31-036	Fault	Overtemperature	
31-039	Fault	Battery Overvoltage EPO	Battery Overvoltage emergency power off
32-003	Fault	Rectifier Stopped Due to Fault	
32-024	Fault	E.P.O.	
32-025	Fault	Rectifier Precharge Failure	
32-026	Fault	Rectifier Precharge Failure	
32-027	Fault	Rectifier Precharge Failure	
32-028	Fault	Rectifier Temperature fault	Check air flow and fans
32-029	Fault	Rectifier Temperature Fault	
32-030	Fault	Rectifier Temperature Fault	
32-031	Fault	Rectifier DC Overvoltage	
32-032	Fault	Rectifier Desaturation Failure	
32-033	Fault	Rectifier Desaturation Failure	
32-034	Fault	Rectifier desaturation Failure	
32-035	Fault	Rectifier Synchronization Failure	Rectifier cannot synchronize with mains
32-036	Fault	Rectifier Overcurrent Failure	Continuous Overcurrent
32-045	Fault	Battery Overvoltage EPO	Battery overvoltage emergency power off
32-046	Fault	Rectifier Desaturation XINT	
32-047	Fault	Rectifier Desaturation Generic	
33-009	Fault	Charger on Command, but Input Voltage is too Low	Defective charger input fuses or defective charger
33-016	Fault	Charger Hardware Failure	No connection to the charger or defective charger
33-017	Fault	Charger Overcurrent	Current limitation control lasts >10ms, charger tripped
33-018	Fault	Charger Temperature High	Temperature above threshold or not reliable
33-019	Fault	Charger Temperature High	
33-020	Fault	Charger Temperature High	
33-021	Fault	Charger De-Saturation	Charger IGBT de-saturation
33-022	Fault	Charger Redundant Voltage Error	Primary and secondary voltage acquisition difference
33-023	Fault	Charger DC Bus	DC Bus Overvoltage
33-025	Fault	Charger Voltage out of Limit	Charger switched off due to an overvoltage of the battery
33-035	Fault	E.P.O.	
33-037	Fault	Battery Overvoltage EPO	Battery overvoltage emergency power off
34-005	Fault	There is no Battery Connected	Connect the Battery
34-009	Fault	Battery Switch Open	Connect the battery
34-011	Fault	Rest time exceeded	The calculated battery rest time is now under the low battery signal time

**Table 4** UPS status, warning and fault messages (continued)

Message ID #	Message Type/Severity	Name	Description
34-013	Fault	Depleted battery	The Battery remaining time is estimated to be close to 0
34-019	Fault	External Battery Breaker Open	Close the battery breaker
34-021	Fault	Reverse Polarity	Check battery connection polarity
34-022	Fault	Battery Overvoltage	
34-023	Fault	Battery Test Failure	A battery test stopped due to a fault
34-024	Fault	Battery Fuse is Blown	A Battery fuse has opened
34-061	Fault	DC Ground Fault	
35-009	Fault	E.P.O.	
35-010	Fault	DC Bus Overcurrent	
35-011	Fault	Booster/Charger Overtemperature	
35-012	Fault	Booster/Charger Overtemperature	
35-013	Fault	Booster/Charger Overtemperature	
35-014	Fault	Booster/Charger Desaturation	
35-015	Fault	Battery Voltage Measurement Malfunction	The battery voltage measurement reports a malfunction
35-016	Fault	Charger DC Bus	DC bus overvoltage
35-019	Fault	Battery Overvoltage EPO	Battery overvoltage emergency power off
36-034	Fault	E.P.O.	
36-035	Fault	Overtemperature	Verify if fans are working properly, and reset the fault
36-036	Fault	Overtemperature	
36-038	Fault	Overtemperature	
36-039	Fault	Overtemperature	
36-040	Fault	Overtemperature	
36-041	Fault	Overtemperature	
36-042	Fault	Overtemperature	
36-043	Fault	Overtemperature	
36-044	Fault	Overload	Investigate the cause of the overload condition and reset the fault
36-045	Fault	Overload	
36-046	Fault	Overload	
36-047	Fault	DC Overvoltage	Inverter is off due to an overvoltage condition in the DC bus
36-048	Fault	Output out of Tolerance	
36-049	Fault	Output out of Tolerance	
36-050	Fault	Output out of Tolerance	
36-051	Fault	Output out of Tolerance	
36-052	Fault	Output out of Tolerance	
36-053	Fault	Output out of Tolerance	
36-054	Fault	Output out of Tolerance	
36-055	Fault	Inverter DC/AC Desaturation	Replace the PSDR boards
36-056	Fault	Inverter DC/AC Desaturation	
36-057	Fault	Inverter DC/AC desaturation	
36-058	Fault	Battery Contactor is Defective	Replace the PSDR boards
36-059	Fault	DC Bus Undervoltage	

**Table 4 UPS status, warning and fault messages (continued)**

Message ID #	Message Type/Severity	Name	Description
36-083	Fault	Battery Overvoltage EPO	Battery Overvoltage Emergency Power Off
36-084	Fault	Inverter Desaturation XINT	
36-085	Fault	Inverter Desaturation Generic	
38-014	Fault	CAN Communication Lost	Check communication cable and DSP
38-016	Fault	Internal Communication Failure	
39-030	Fault	EPO Active	
39-033	Fault	Backfeed Protection Active	
39-034	Fault	Overtemperature	
39-040	Fault	SCR Gate Corrupt	
39-041	Fault	Output Overvoltage	
39-042	Fault	Output Undervoltage	
39-043	Fault	Output Frequency out of Limits	

## 4.0 CONNECTIVITY

### 4.1 NETWORK AND BMS CONNECTIVITY AND MONITORING

Communications cards for SNMP, Modbus, or both (Dual Protocol) are available, supporting Modbus over IP or RS-485. These cards also support browser access to the UPS's Web page, which displays critical operational values and conditions. Any of these cards can be installed in the XS3 slot. However, the unit must be configured to support the card (ManageUPS, Liebert IS-UNITY or Liebert IS-485EXI).

#### 4.1.1 Determining the type of Card in Your System

The Liebert IS-UNITY-DP, the Liebert IS-485EXI and the ManageUPS cards are labeled accordingly. Contact Vertiv Liebert Services™ for information about installing a card if one was not factory-installed.

### 4.2 CONNECTION POINTS

**Table 5** gives details of the various combinations of connectivity solutions that can be used with the Liebert NX. Only one of the combinations may be used at a time. Other combinations may be possible. The interfaces in **Table 5** can be found on the Liebert NX.

**Table 5** Connectivity combinations

Interface	Description	Input/Output/Serial/CAN
XS3	Slot available for use with a connectivity option, typically a Liebert IS-UNITY-DP™ Card or ManageUPS NET III Adapter for SNMP, Modbus or both or a Liebert IS-485EXI may be installed for Liebert SiteScan®.	Serial
XS6	Slot for the LIFE.net slot modem	Serial
X3	Standard serial interface RS232 COM - female – Available, if XS3 slot is empty or a Liebert IS-UNITY-DP Card or ManageUPS NET III Card is installed	Serial
X6	LIFE™ Services card only	Serial
X19	2x15-pole screw connector for parallel UPS connection	—
X20	RJ45 interface for synchronization with external signal	—
TB1	16-pole screw connector for input contacts (see <b>4.2.1 - Available Selectable Input Contacts</b> )	Input
TB2	16-pole screw connector for output contacts (see <b>4.2.2 - Available Selectable Output Contacts</b> )	Output
XT 3/8	4-pole screw for EPO input and output	Input and Output
XT1/2	Not Used	—
TB3	Battery Interface and SKRU Key Status	Input and Output
TB4	SKRU Enable Status	Input and Output

## 4.2.1 Available Selectable Input Contacts



### NOTE

*These contacts must be programmed by an Vertiv customer engineer.*

Standby Generator Set (SGS)	Bypass and Inverter both Off (See Note 3)
Bypass Operation (See Note 1)	Stop Battery Test (See Note 2)
Fast Power Off	External Output Breaker (See Note 4)
External Maintenance Bypass	Mirrored Standby Generator Set (SGS)
Start Battery Test (See Note 2)	Force Rectifier Off then On
Fault Acknowledge	DC Ground Fault Detection

### Notes on Selectable Input Contacts

1. Activating this input contact will force the UPS to transfer from Inverter to Bypass Mode of operation. When deactivated, the UPS will automatically transfer back to Inverter Mode of operation. Selecting this function disables the *Start Inverter* and *Stop Inverter* buttons on the touchscreen LCD.
2. The contact must remain active at least 15 seconds to ensure that the command is accepted.
3. Activating this input contact switches Off both the inverter and the bypass static switch. The load will no longer be supplied. When this input contact is deactivated, the UPS switches the bypass static switch On for a short period and then the inverter. The *Start Inverter* and *Stop Inverter* buttons on the touchscreen LCD are disabled when this function is selected.
4. Activating this input contact allows the inverter to turn On. When deactivated, the UPS forces the inverter to turn Off.
5. The logic for each input contact can be inverted.
6. Each input contact can have a turn On delay of 0-60 seconds.
7. Each input contact can have a turn Off delay of 0-60 seconds.

## 4.2.2 Available Selectable Output Contacts

When output contacts configuration is “Custom,” then it is possible to define the associated switch-on condition for each output contact.

The possible conditions are indicated by values description. Cyclic treatment for the output contacts is executed each 32ms.

Summary alarm (fault / warning)	Bypass Mains Failure
Inverter not On	Battery Overtemperature
Residual Battery Autonomy is Expiring	SGS On (Standby Generator Set)
Rectifier or Bypass Mains Failure	Battery Prewarning level
Inverter On	Battery Capacity LEVEL25
Load Supplied by Battery	Battery Capacity LEVEL50
Bypass Active (AS400-like)	Battery Capacity LEVEL75
Maintenance Bypass Switch Closed	Battery Capacity LEVEL100
Inverter Operation, Self-Clocked	Load LEVEL25
Shutdown Command Pending	Load LEVEL50
Summary Fault	Load LEVEL75
Inverter Stopped Due to Fault	Load LEVEL100
Bypass Stopped Due to Fault	Load LEVEL105
Rectifier Fault	Line Fault
Summary Warning	Summary Alarm OR Line Fault
Inverter Overtemperature Warning	Power loss Prewarning
Imminent Shutdown	Power Loss Alarm
Battery Undervoltage	Backfeed Fault
Inverter Overload	AC Output Ground Fault
Rectifier or Bypass Mains Failure	SGS Input Function Active
Rectifier Mains Failure	Mirrored SGS Input Function Active
	Eco Mode Active

### Notes on Selectable Output Contacts

1. The logic for each output contact can be inverted.
2. Each output contact can have a turn On delay of 0 to 60 seconds.
3. Each output contact can have a turn Off delay of 0 to 60 seconds.

## 5.0 MAINTENANCE

### 5.1 SAFETY PRECAUTIONS

Observe the safety precautions in **Battery Cabinet Precautions on page 2**.

Observe all of the warnings below before performing any maintenance on the UPS and associated equipment. Also observe the manufacturer's safety precautions pertaining to the DC source, along with the DC source safety precautions in this section.



#### NOTE

*Service and maintenance work must be performed only by properly trained and qualified personnel and in accordance with applicable regulations as well as with manufacturers' specifications.*



#### WARNING

Risk of electric shock and high short circuit current. Can cause equipment damage, injury and death.

- Extreme caution is required when performing maintenance.
- Be constantly aware that the UPS system contains high DC as well as AC voltages. With input power Off and the DC source disconnected, high voltage at filter capacitors and power circuits should be discharged within 5 minutes. However, if a power circuit failure has occurred, you should assume that high voltage may still exist after shutdown. Check with a voltmeter before making contact.
- AC voltage will remain on the bypass and output circuit breakers and the static bypass switch, unless associated external circuit breakers are opened.
- Check for voltage with both AC and DC voltmeters before making contact.
- When the UPS system is under power, both the operator and any test equipment must be isolated from direct contact with earth ground and the UPS chassis frame by using rubber mats.
- Some components within the cabinets are not connected to the chassis ground.
- Any contact between floating circuits and the chassis is a lethal shock hazard. Use differential oscilloscopes when measuring a floating circuit.
- Exercise caution that the test instrument exterior does not make contact, either physically or electrically, with earth ground.
- In case of fire involving electrical equipment, use only carbon dioxide fire extinguishers or others approved for use in fighting electrical fires.



#### WARNING

Risk of electric shock and high short circuit current. Can cause equipment damage, injury and death.

- Always identify connecting wiring before disconnecting any wiring.
- Do not substitute parts except as authorized by Vertiv.
- Keep the UPS cabinets free of foreign material, such as solder, wire cuttings, etc.
- Contact Liebert Services if you are not sure of the procedures to follow or if you are unfamiliar with the circuitry.

### 5.2 VERTIV LIEBERT SERVICES

Startup, UPS maintenance, DC source maintenance and training programs are available for the Liebert NX through your Vertiv sales representative.

#### Warranties

Contact Liebert Services if you have any questions regarding the warranty on your Liebert NX UPS or the batteries.



## 5.3 ROUTINE MAINTENANCE

Become thoroughly familiar with the equipment, but at no time go beyond the specific procedures in this manual while performing maintenance or correcting a malfunction.

If you have any doubt about what must be done, call Liebert Services at 1-800-LIEBERT for further instructions.

The UPS is designed for unattended operation, but does require some common-sense maintenance.

- Keep good records—Troubleshooting is easier if you have historical background.
- Keep it clean—Keep the UPS free of dust and moisture.
- Keep it cool—Battery systems must be kept in the range of 72-77°F (22-26°C) to meet design specifications for capacity and longevity.

The UPS will reliably meet all performance specifications and design life at temperatures up to 104°F (40°C). However, performance and longevity will be optimized when the UPS is operated at the same temperature as the batteries. Contact your local Vertiv sales representative or call 1-800-LIEBERT for further details.

- Keep connections tight—Tighten all connections at installation and at least annually thereafter (see **Table 8**.)
- Keep it inspected—Periodically inspect external upstream and downstream circuit breakers to ensure that the trip current settings are correct.

Become familiar with typical ambient conditions surrounding equipment so that abnormal conditions may be more quickly recognized. Know what typical meter readings are and where adjustable settings should be.

### 5.3.1 Record Log

Set up a maintenance log to record scheduled checks and any abnormal conditions.

The log should have space for all metered parameter indications including phase readings, alarm messages, UPS mode of operation, air filter replacement date and observation notes. A second log should be maintained for the DC source as directed by the DC source manufacturer.

A periodic walk-through inspection of the UPS and DC source rooms is advised to check for visible and audible indications of problems. Log the inspection, metered parameter indications and any discrepancies.

### 5.3.2 Air Filters

The air filters must be inspected and serviced on a regular schedule. The period between inspections will depend upon environmental conditions. Under normal conditions, the air filters will require cleaning or replacement approximately every two months. Abnormal or dusty conditions will require more-frequent cleaning and replacement of air filters. Inspect installations in new buildings more often, then extend the inspection period as experience dictates.

All Liebert NX models have a replaceable air filter inside the front doors. These filters can be changed while the UPS is in operation.



#### NOTE

*Service and maintenance work must be performed only by properly trained and qualified personnel and in accordance with applicable regulations as well as with manufacturers' specifications.*

### 5.3.3 Limited Life Components

The Liebert NX has a design life well in excess of 10 years. Well-maintained units can continue to provide economic benefits for 20 years or more. Long-life components are used in the UPS wherever practical and cost-effective. However, due to the currently available component material, manufacturing technology limitations and the general function and use of the component, a few components in the Liebert UPS will have a shorter life cycle and require replacement in less than 10 years.

The following components utilized in the UPS have a limited life cycle and are specifically exempt from warranty. To prevent a wear-out failure of one of these components affecting the critical load operations, Vertiv recommends these components be periodically inspected and replaced before the expected expiration of their life cycle. The expected life of each component listed below is simply an estimate and is not a guarantee. Individual users may have site-specific requirements, maintenance and other environmental conditions that affect the length of the component's useful life cycle.

In most cases, replacement components must exactly match the original component specifications.

These replacement components are not readily available from third-party component distributors.

For assistance with specific component specifications, replacement component selection and sourcing, call 1-800-LIEBERT. For customers using Liebert Services' preventive maintenance services, periodic inspection of these components is part of this service, as well as recommending component replacement intervals to customers to avoid unanticipated interruptions in critical load operations.

**Table 6 UPS component service life**

Component	Expected Life	Replace in:
Power AC Filter Capacitors	15 years	12 to 15 years
Power DC Filter Capacitors	15 years	12 to 15 years
Low-Profile Fans	> 7 years	5 to 6 years
Air Filters	1 to 3 years	Check four times per year
Battery, Lithium Logic Memory Backup	10 years	8 to 9 years
<b>Battery, Storage</b>		
Lead-acid Wet-cell (User Selection)	15 to 20 years	12 to 15 years
Valve-Regulated, Lead-Acid (VRLA)	5 years	2 to 3 years
	10 years	3 to 4 years
	20 years	8 to 12 years

"Expected Life" is sometimes referred to as "Design Life."

## 5.4 BATTERY MAINTENANCE

### **WARNING**

Risk of electric shock and high short circuit current. Can cause equipment damage, injury and death.

- These maintenance procedures will expose hazardous live parts. Refer servicing to properly trained and qualified personnel working in accordance with applicable regulations as well as with the manufacturers' specifications.
- DC fuses operate at the rated battery voltage at all times. A blown DC bus fuse indicates a serious problem. Serious injury or equipment damage can result if the fuse is replaced without knowing why it failed and without the cause corrected. Contact Liebert Services for assistance.

### 5.4.1 Battery Safety Precautions

Servicing of batteries should be performed or supervised by personnel knowledgeable of batteries and the required precautions. Keep unauthorized personnel away from batteries.

When replacing batteries, use the same number and type of batteries.

### **WARNING**

Risk of electric shock, explosive reaction, hazardous chemicals and fire. Can cause equipment damage, injury and death.

Lead-acid batteries contain hazardous materials. Batteries must be handled, transported and recycled or discarded in accordance with federal, state and local regulations. Because lead is a toxic substance, lead-acid batteries must be recycled rather than discarded.

Do not dispose of battery or batteries in a fire. The battery may explode.

Do not open or mutilate the battery or batteries. Released electrolyte is harmful to the skin and eyes. It is toxic.

### **WARNING**

Risk of electric shock and high short circuit current. Can cause equipment damage, injury and death.

The following precautions must be observed when working on batteries:

- Remove watches, rings and other metal objects.
- Use tools with insulated handles.
- Wear rubber gloves and boots.
- Do not lay tools or metal parts on top of batteries.
- Disconnect charging source prior to connecting or disconnecting battery terminals.
- Determine whether the battery is grounded. If it is grounded, remove source of ground.
- Contact with any part of a grounded battery can result in electrical shock. The likelihood of such shock will be reduced if such grounds are removed during installation and maintenance.

### **WARNING**

Risk of explosion and fire. Can cause equipment damage, injury and death.

- Lead-acid batteries present a risk of fire because they generate hydrogen gas, which is explosive. In addition, the electrical connections must be protected against short circuits and other sources of sparks. The following procedures should be followed:
  - Do not smoke near batteries.
  - Do not cause flame or spark in battery area.
  - Discharge static electricity from your body before touching batteries by first touching a grounded metal surface.
  - After replacing battery jars in a battery cabinet, replace the retaining straps that hold the jars in place on the shelves. This will limit accidental movement of the jars and connectors should the cabinet need to be repositioned or relocated.

Regular maintenance of the battery module is an absolute necessity. Periodic inspections of battery and terminal voltages, specific gravity and connection resistance should be made. Strictly follow the procedures outlined in the battery manufacturer’s manual, available on the manufacturer’s Web site.

Valve-regulated lead-acid (sealed-cell) batteries do require periodic maintenance. Although maintenance of electrolyte levels is not required, visual inspections and checks of battery voltage and connection resistance should be made.

**NOTICE**

Risk of improper cleaning. Can cause equipment damage.

Batteries should be cleaned with a dry cloth or a cloth lightly moistened with water. Do not use cleaners on the batteries. Solvents can make the battery cases brittle.

Because individual battery characteristics are not identical and may change over time, the UPS module is equipped with circuitry to equalize battery cell voltages. This circuit increases charging voltage to maintain flooded type battery cells at full capacity.

 **WARNING**

Risk of electric shock, explosive reaction, hazardous chemicals and fire. Can cause equipment damage, injury and death.

Do not use equalize charging with valve-regulated, lead-acid batteries. Refer to the battery manufacturer’s manual, available on the manufacturer’s Web site, for specific information about equalize charging.

**Matching Battery Cabinets—Optional**

Although individual battery cells are sealed (valve-regulated) and require only minimal maintenance, the Battery Cabinets should be given a periodic inspection and electrical check. Checks should be performed at least annually to ensure years of trouble-free service.

**Voltage Records:** With the Battery Cabinet DC circuit breaker closed and the connected UPS operating, measure and record battery float voltage. With the DC circuit breaker open, measure and record the nominal (open circuit) voltage. Both these measurements should be made across the final positive and negative terminal lugs. Compare these values with those shown below. The recorded nominal voltage should be no less than the value shown; while the recorded float voltage should be within the range shown. If a discrepancy is found, contact Liebert Services.

**Table 7 Battery voltage, nominal and float**

Number of Cells	Battery Voltage, VDC	
	Nominal	Float
240	480	527 - 552

Contact the factory for information about charging lithium ion batteries.

**Power Connections:** Check for corrosion and connection integrity. Inspect wiring for discolored or cracked insulation. Clean and/or retighten as required. Refer to torque specifications in **Table 8**.

**Battery Cell Terminals:** Check for discoloration, corrosion and connection integrity. Clean and tighten if necessary. NOTE that when installing a new battery, the initial torque value is 5 lb.-in. more than the retorquer value. **Table 8** shows battery retorquer values.

**Table 8 Battery retorquer values**

Battery Mfr.	Battery Model #	Retorquer Value in-lb (N-m)
C&D	UPS12-300MR	110 (12.4)
	UPS12-350MR	
	UPS12-400MR	
	UPS12-490MR	
	UPS12-540MR	
	UPS12-545PLP	
	UPS12-600MR	
	UPS12-605PLP	
Energys	HX205-FR	65 (7.3)
	HX300-FR	
	HX330-FR	
	HX400-FR	
	HX500-FR	
	HX540-FR	
	16HX800F	100 (11.3)
	16HX925F	
East Penn	HR3000	65 (7.3)
	HR3500	
	HR4000	
	HR5000	
	HRH5500	

If the system uses a different model battery, contact Liebert Services for the required torque value.

To access battery cell terminals, disconnect the inter-tier cable and two shelf retaining screws. Once disconnected, insulate the cables with protective boot or electrical tape to prevent accidental shorts.

The battery shelves can be pulled out. Tighten each terminal connection to the retorquer value.

When replacing a battery, the terminal connections must be cleaned and tightened. Disconnect and insulate the cables connected to the battery. Secure each battery shelf with retaining screws when maintenance is complete.

**Other DC Sources**

If the UPS system uses a DC source other than a factory-supplied Matching Battery Cabinet, perform maintenance on the DC source as recommended in the DC source manufacturer’s maintenance manual, available on the manufacturer’s Web site.

## 5.5 DETECTING TROUBLE

The operator must check the instrument readings if abnormal equipment performance is suspected. Any metered value that differs appreciably from normal could mean an impending malfunction and should be investigated.

### 5.5.1 Items to check include:

- If the UPS has not operated on battery power during the last 10 hours, the batteries should require little charging current. Battery mimic should indicate normal DC voltage with the battery charge current no more than 1% of maximum discharge current.
- Input current on each phase should be within 10% of the average input current.
- Alarm messages indicate malfunction or impending malfunction. A daily check of the Display Screen will help to provide an early detection of problems.
- Tracing a problem to a particular section is facilitated by alarm messages and the metered parameter indications.

### NOTICE

Risk of recurring problem. Can cause degraded performance and equipment damage.

If the UPS system has an open fuse, the cause should be determined before replacing the fuse. If the cause is not corrected, it could recur. Contact Liebert Services for assistance.

## 5.6 REPORTING A PROBLEM

If a problem occurs within the UPS, review all alarm messages along with other pertinent data. Contact Liebert Services at 1-800-LIEBERT to report a problem or to request assistance.

## 5.7 UPSTREAM FEEDER CIRCUIT BREAKER SETTING INSPECTIONS

During normal UPS operations, short-term overload current demand from the bypass source may reach 10 times the UPS output current rating. This overload current demand may be caused by the magnetizing inrush current of one or more downstream transformers (e.g., power distribution units) or faults on downstream branch circuits. The instantaneous trip point(s) of the upstream bypass feeder breaker(s) must be set to support these temporary overloads. The magnitude of short-term overload bypass current demand is typically six to eight times the UPS current rating, but must be determined by analysis on a per-site basis. This analysis, generally known as an End-to-End Fault Coordination Study, must be done by a registered professional engineer experienced in this activity and familiar with local codes and related requirements.

Vertiv strongly recommends periodic inspections of the bypass feeder breaker instantaneous trip settings, as well as the module input (rectifier) feeder breaker trip settings, to ensure that they are correct. For a variety of reasons, although typically during circuit breaker maintenance procedures by others, trip settings have been known to be inadvertently left improperly set. Correct trip setting of these circuit breakers is most important to achieving high-availability from your Liebert UPS system.

For further information regarding proper trip settings for your feeder breakers, call 1-800-LIEBERT.



### NOTE

*The instantaneous trip setting of the breaker feeding the UPS bypass input should be high enough to accommodate short-duration overloads. The bypass static switch power path inside the UPS can draw up to 10 times the system's rated current for up to three cycles.*



### NOTE

*While Vertiv can provide typical guidelines, the responsibility for the proper breaker trip settings outside the Vertiv-manufactured UPS equipment resides with the owner. Contact Liebert Services at 1-800-LIEBERT for further information.*

## 5.8 AC OUTPUT GROUND FAULT DETECTION

A phase-to-ground fault that occurs while the UPS is supporting the load from a DC source will cause the UPS's inverter and battery to float. The return path for fault current will be interrupted and the return path for AC ground faults on the output of the UPS will be interrupted.

The Liebert NX 225-600 is equipped with special circuitry to detect such faults and display a warning on the touchscreen LCD. The warning may also be communicated through a programmable output contact to third-party devices.

When such an event occurs, the load should be removed from the UPS output as quickly as possible to avoid damage that could occur if power returns suddenly. Remove power to the UPS input terminals by opening the input breakers. Power should stay disconnected until the fault has been corrected.



### NOTE

*An AC phase-to-ground fault will clear under normal conditions with utility power present and the rectifier powering the inverter.*

## 6.0 SPECIFICATIONS

---

### 6.1 DC SOURCES

#### 6.1.1 Battery Operation

The separate battery manufacturer's manual, available on the manufacturer's Web site, provides the necessary information for the installation, operation and maintenance of the battery. Use the battery manual in conjunction with this manual.

The float charge voltage for a battery is equal to the number of cells in series making up the battery multiplied by the charge voltage for each cell.

Because the charging voltage level is critical to proper battery operation, refer to your battery manual, available on the manufacturer's Web site, for information about your system.

For models with nominal 240-cell battery, the DC bus nominal float voltage range for VRLA batteries is 2.15 to 2.30VPC.

Battery voltage at end of discharge is 1.65VPC at the UPS terminals. The number of battery cells required ranges from 228 to 246, depending on the application.

### 6.2 OTHER DC SOURCES

The separate DC source manufacturer's manual, available on the manufacturer's Web site, provides the necessary information for the installation, operation and maintenance of the DC source. Use the DC source manual in conjunction with this manual. Liebert NX UPS's with firmware version 1.09 and later, minimum walk-in time is 2.5 seconds.

### 6.3 BATTERY DC GROUND FAULT DETECTION

Vertiv offers battery DC ground fault detection solutions as an option for the Liebert NX 225-600kVA UPS. Some jurisdictions and customers require that there be a system to detect battery DC ground faults in ungrounded DC systems. Generally, this applies to DC systems that are field-wired to the UPS. This includes both battery and flywheel systems. The National Electrical Code does not require DC systems (such as Liebert Matching Battery Cabinets), which are attached directly to the UPS and do not require field-wiring, to have this capability.

However, local codes may have different interpretations, and customers may also have internal requirements for this capability. Because of this, Vertiv recommends that customers understand all of the applicable requirements to determine whether a DC ground fault detection system is needed.

For more information on Liebert battery ground fault solutions, contact your Liebert representative.



## 6.4 ENVIRONMENTAL CONDITIONS

**Table 9 Environmental specifications**

Parameter	Specification
Enclosure	The UPS is housed in a NEMA-1 enclosure. The enclosure is designed for indoor use only and is not to be subjected to falling objects or precipitation.
Recommended Operating Temperature, °F (°C)	77 (25) ambient
Maximum Operating Temperature, °F (°C)	104 (40) ambient (design temperature) without derating; (see Notes 2 and 3).
Minimum Operating Temperature, °F (°C)	32 (0)
Storage Temperature, °F (°C)	-13 to 158 (-25 to 70)
Typical Battery Temperature Requirements	Average annual temperature must not exceed 80°F (27°C). Peak temperature must not exceed 109°F (43°C). See battery manufacturer's recommendations.
Relative Humidity	0 to 95% without condensation
Operating Elevation, ft. (m)	Sea level to 3300 (1000) without derating
Storage Elevation, ft. (m)	Sea level to 50,000 (15,240)
Audible Noise, 5ft (1.5m) from Unit	68 dBA, typical

### Notes on Environmental Specifications

1. This category of electronic equipment is agency rated for use in an atmosphere free of conductive particles. Some industrial facilities may require a room air filtration system to keep the UPS free of excess moisture and contaminants.
2. The UPS system is designed to operate continuously at 104°F (40°C). However, design equipment life expectancy will be extended with lower temperatures (77°F [25°C] is recommended).
3. Ambient temperature is the maximum ambient temperature during any 24-hour period. For operation at higher temperatures, consult your Vertiv sales representative or call Liebert Services at 1-800-LIEBERT.
4. Exercise care during installation to ensure unimpeded airflow through the UPS.
5. For operation at higher elevations, consult your Vertiv sales representative or call Liebert Services at 1-800-LIEBERT.

## 6.5 THERMAL RUNAWAY PROTECTION

The Liebert NX 225-600kVA UPS is equipped with the capability to meet the requirements of the International Fire Code 2012 Section 608.3. This is included in systems with firmware release 1.09 or later, shipped in 2015 or later. Contact your Liebert Services representative for information about firmware upgrades.

To determine the firmware version in your Liebert NX 225-600 UPS, go to display screen and press the Help button, then press About. The revision number will be displayed.

The thermal runaway protection system works as follows:

1. The UPS still features a temperature-compensated charging system, which reduces charge current as battery temperature rises above a base level, which is 20°C. The UPS monitors the temperature sensors in all battery cabinets, and reports and displays the highest value reported on its user display and BMS interface.
2. When the temperature of any battery cabinet exceeds a threshold, (configurable, 30°C is the default) a High Battery Temperature warning will be generated and displayed on the user display, BMS interface and LIFE Services™ messaging. The UPS stops compensating at this point.
3. When a second threshold is exceeded by any of the battery cabinets, the charger is turned Off. (This should be set to 40-43°C by Liebert Services to comply with warranty requirements). The UPS will display:
  - The High Battery Temperature message;
  - A message that Battery Temperature is Over Limit;
  - Messages will also indicate that the charger is switched Off, and the charger icon on the touchscreen LCD will be gray;
  - Messages will also be generated and displayed on the BMS interface and LIFE Services™ messaging.
4. The customer has a choice of responses, based on requirements and battery configuration:
  - Stop the charger (charger will restart when the temperature drops to 2°C below the threshold (38-41°C, depending on where the threshold is set);

OR

  - Stop the charger and open the breaker on the overtemperature cabinet only; the UPS will then resume charging the remaining battery cabinets normally.

The selection must be programmed by Liebert Services.
5. If the UPS does not detect a functioning temperature sensor, it will display the message: *Probe not connected or Broken*.
6. Configurable options with this system include:
  - Activating contacts to interface with external customer devices;
  - Adding a hydrogen sensor to the UPS by configuring an input contact to stop charging upon reaching a given hydrogen level;
  - Connecting a fan sensor to the UPS to stop charging if a ventilation fan in the battery space fails.

**Table 10 Electrical specifications**

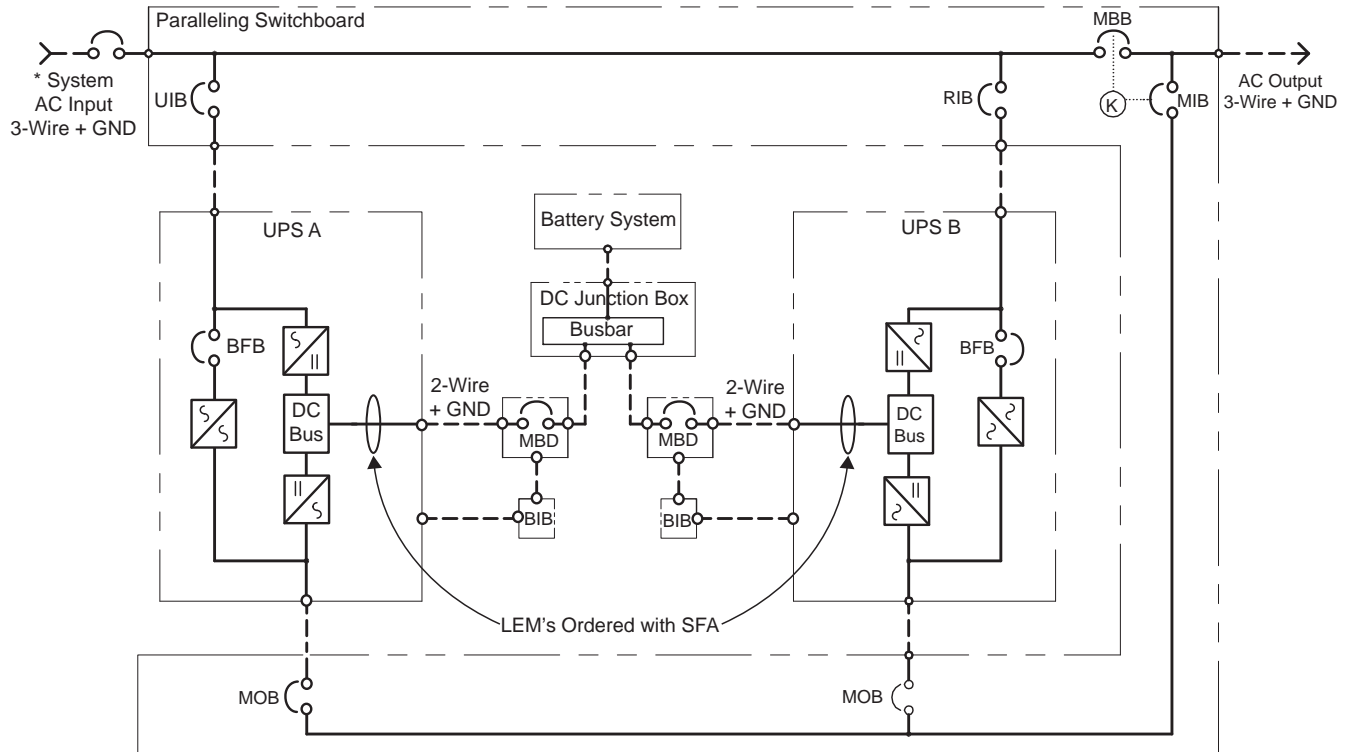
Input Parameters	
Input Voltage to Rectifier, VAC, 3-phase, 3-wire	480V
Input Voltage to Bypass, VAC, 3-phase, 3-wire	480V
Input Voltage Range, VAC	+10% to -30%
Input Frequency, Hz	60
Permissible Input Frequency Range, Hz	55-65
Rectifier Power Walk-In, sec	2.5 to 90 seconds adjustable
DC Parameters	
Battery Type	VRLA (Valve Regulated Lead Acid) or FLA (Flooded Lead Acid)
DC Bus Range, VDC	396-600
DC Float Voltage, VPC	2.27
End-Cell Voltage, VPC	1.65 (for VRLA / FLA)
DC Ripple Voltage in Float and Const V Ch. mode, %	<1 (RMS Value) < 3.4% Vpp
Output Parameters	
Output Voltage, 3-phase, 3-wire	480V
Output Voltage Regulation, %	< 1% (3-Phase RMS Average)
Output Frequency, Hz	60
Output Frequency Regulation, %	± 0.1
Capacity to Handle Step Load, %	0-100 or 100-0
Voltage Displacement, ° el	120° ±1° el (With Unbalanced Load)
Compliance to FCC Class-A	Standard

**Table 11 Physical specifications**

Liebert NX Model Size	225	250	300	400	500	600
Physical Parameters and Standards, in (mm)						
Width	53.4			90.7		
Depth	33.7					
Height	78.6					
Weight, Unpackaged, approximate, lb. (kg)	2450 (1110)			4450 lb. (2019kg)		
Maximum Heat Dissipation, Full Load, BTU/hr	41,000	45,000	54,000	72,000	90,000	108,000
<b>Color</b>	Black (ZP-7021)					
<b>Front Door Opening (for serviceability)</b>	More than 90°					
<b>Degree of Protection for UPS Enclosure</b>	IP 20 (with and without front door open)					
<b>Minimum Clearance, Top, In. (mm)</b>	24 (610)					
<b>Minimum Clearance, Back, In. (mm)</b>	0					
<b>Minimum Clearance, Sides, In. (mm)</b>	0					
<b>Cable Entrance Location</b>	Top or Bottom					
<b>Standards &amp; Conformities</b>	UL, 1778, 4th Ed.					
	CSA 22.2 107.3					
	FCC Part 15, Class A					
	IEC62040-2, Level 4, Criteria A					
	EN61000-4-3, Level 3, Criteria A					
	EN61000-4-6, Level 4, Criteria A					
	EN61000-2-2, Criteria A					
	EN61000-4-4, Level 4, Criteria A					
	ANSI C62.41, Category A3 & B3					
	ISTA Procedure 1H					
WEEE						

# APPENDIX A - SYSTEM CONFIGURATION

Figure 40 Two-module 1+N UPS system, single input, common battery and paralleling switchboard



**LEGEND**

- RIB - Rectifier Input Breaker
- MOB - Module Output Breaker
- MIB - Maintenance Isolation Breaker
- MBB - Maintenance Bypass Breaker
- BFB - UPS Backfeed Breaker
- BIB - Battery Interface Board
- MBD - Module Battery Disconnect
- K - Key Interlock System (optional)

----- Field-Supplied Wiring

\* External overcurrent protection by others

**NOTES**

1. AC input and output cables must be run in separate conduits.
2. All power cables from DC supply should be sized for a total maximum 2V drop at maximum discharge current.
3. Control wiring and power wiring must be run in separate conduits.
4. Grounding conductors are recommended.

U38-CA-1020  
Rev. 1

## **TECHNICAL SUPPORT / SERVICE**

### **Web Site**

[www.vertivco.com](http://www.vertivco.com)

### **Monitoring**

[liebert.monitoring@vertivco.com](mailto:liebert.monitoring@vertivco.com)

800-222-5877

Outside North America: +00800 1155 4499

### **Three-Phase UPS & Power Systems**

800-543-2378

Outside North America: 614-841-6598

## **LOCATIONS**

### **United States**

1050 Dearborn Drive

P.O. Box 29186

Columbus, OH 43229

### **Europe**

Via Leonardo Da Vinci 8

Zona Industriale Tognana

35028 Piove Di Sacco (PD) Italy

+39 049 9719 111

Fax: +39 049 5841 257

### **Asia**

29/F, The Orient Square Building

F. Ortigas Jr. Road, Ortigas Center

Pasig City 1605

Philippines

+63 2 687 6615

Fax: +63 2 730 9572

---



**VertivCo.com | Vertiv Headquarters, 1050 Dearborn Drive, Columbus, OH, 43085, USA**

© 2016 Vertiv Co. All rights reserved. Vertiv and the Vertiv logo are trademarks or registered trademarks of Vertiv Co. All other names and logos referred to are trade names, trademarks or registered trademarks of their respective owners. While every precaution has been taken to ensure accuracy and completeness herein, Vertiv Co. assumes no responsibility, and disclaims all liability, for damages resulting from use of this information or for any errors or omissions. Specifications are subject to change without notice.

SL-25354\_REV4\_12-16