



**UNI JET**

**ИБП Liebert NX (225-600 кВА) - руководство по установке. Юниджет**

Постоянная ссылка на страницу: <https://www.uni-jet.com/catalog/ibp/online-ibp/liebert-nx/>





# Liebert® NX™ UPS

Installation Manual — 225-600kVA, 1.0PF, 60Hz, Three-Phase, Single-Module & Multi-Module

# CONTACTING VERTIV FOR SUPPORT

To contact Vertiv Liebert Services for information or repair service in the United States, call 800-543-2378. Liebert Services offers a complete range of startup services, repair services, preventive maintenance plans and service contracts.

For repair or maintenance service outside the 48 contiguous United States, contact Liebert Services, if available in your area. For areas not covered by Liebert Services, the authorized distributor is responsible for providing qualified, factory-authorized service.

For Liebert Services to assist you promptly, please have the following information available:

**Part numbers:** \_\_\_\_\_  
**Serial numbers:** \_\_\_\_\_  
**Rating:** \_\_\_\_\_  
**Date purchased:** \_\_\_\_\_  
**Date installed:** \_\_\_\_\_  
**Location:** \_\_\_\_\_  
**Input voltage/frequency:** \_\_\_\_\_  
**Output voltage/frequency:** \_\_\_\_\_  
**Battery reserve time:** \_\_\_\_\_

## Product Warranty Registration

To register for warranty protection, visit the **Service and Support** section of our Web site at:

[www.liebert.com](http://www.liebert.com)

Click on **Product Registration** and fill out the form.

# TABLE OF CONTENTS

CONTACTING VERTIV FOR SUPPORT .....	INSIDE FRONT COVER
<b>IMPORTANT SAFETY INSTRUCTIONS .....</b>	<b>1</b>
<b>SAVE THESE INSTRUCTIONS .....</b>	<b>1</b>
<b>1.0 MECHANICAL INSTALLATION .....</b>	<b>3</b>
1.1 Introduction .....	3
1.2 Preliminary Checks .....	3
1.3 Environmental Considerations.....	4
1.3.1 UPS Room.....	4
1.3.2 Storing the UPS and Batteries for Delayed Installation.....	4
1.3.3 Installation Altitude.....	5
1.4 Positioning .....	5
1.4.1 Moving the Cabinets.....	5
1.4.2 Clearances .....	5
1.4.3 Raised-Floor Installations .....	5
1.4.4 Kick Plates and Floor Anchors for Special Seismic Certification—Optional .....	6
1.4.5 Kick Plate Installation—Standard.....	6
1.4.6 Special Considerations for 1+N Parallel Systems .....	6
1.4.7 Unpacking and Unloading the Cabinet from the Pallet.....	7
1.5 System Composition .....	7
1.6 Cable Entry.....	8
<b>2.0 UPS ELECTRICAL INSTALLATION .....</b>	<b>9</b>
2.1 External Protective Devices .....	9
2.2 Power Cables .....	9
2.3 Sizing the Input Breaker Feeding a Liebert NX UPS.....	10
2.3.1 Single or Dual Input Feeds .....	10
2.3.2 Automatic Transfer Switches.....	10
2.3.3 Power Cable Connection Procedure .....	11
2.4 Control Cable and Communication.....	12
2.4.1 Slot for Liebert IntelliSlot™ or ManageUPS™ Communication Cards—XS3 .....	12
2.4.2 Slot for LIFE Services Products—XS6.....	13
2.4.3 Serial Interface for Liebert LIFE Services Cards (Serial Input/Output)—X6 .....	13
2.4.4 Connector for REPO (Input and Status)—XT3/8.....	13
2.4.5 Customizable Output—TB2 .....	14
2.4.6 Customizable Input Contact—TB1 .....	14
2.4.7 Contact Control for Eco Mode.....	15
2.4.8 Connector for Parallel UPS Connection—X19A, X19B .....	15
2.4.9 RJ-45 Interface for Synchronization with External Signal—X20 .....	15
2.4.10 UPS Control Contacts with Battery Cabinet or Module Battery Disconnect.....	15
2.4.11 UPS Control Contacts with Global Maintenance Bypass .....	16
2.5 Configuring Ground Connections.....	16
2.5.1 Three-Wire Input Connections .....	17
2.5.2 Preferred Grounding Configuration, Battery Systems.....	18
2.5.3 High-Resistance Ground Systems .....	19

2.6	Distributed Static Switch (1+N) System Cabling Layouts .....	19
<b>3.0</b>	<b>OPTIONAL EQUIPMENT .....</b>	<b>23</b>
3.1	Single-Module System Options .....	23
3.1.1	Input Circuit Breaker .....	23
3.1.2	External Battery Temperature Sensor—Optional .....	23
3.1.3	Matching Liebert NX Battery Cabinet.....	23
3.1.4	Battery Interface Box .....	23
3.1.5	Local EPO Button.....	23
3.2	Communication and Monitoring .....	23
3.2.1	Remote Status Panel.....	23
3.2.2	Alber Monitoring System.....	23
3.2.3	Capacity on Demand (Softscale) Upgrades .....	23
3.3	Multi-Module System Options and Accessories .....	24
3.3.1	Paralleling Cable Kit .....	24
3.3.2	Load Bus Sync Controller .....	24
3.3.3	Multi-Bus Synch Module (MBSM).....	24
<b>4.0</b>	<b>INSTALLATION DRAWINGS .....</b>	<b>25</b>
<b>5.0</b>	<b>SPECIFICATIONS.....</b>	<b>37</b>

## FIGURES

Figure 1	Unpacking .....	7
Figure 2	Cabinet arrangement—Liebert NX matching battery cabinets .....	8
Figure 3	Grounding diagram—Three-wire single-module systems.....	17
Figure 4	Grounding diagram—Three-wire multi-module systems.....	18
Figure 5	System layout, 1+N.....	20
Figure 6	SKRU connections .....	21
Figure 7	Control wiring.....	21
Figure 8	REPO connections 1+N system .....	22
Figure 9	Main components, 225-300kVA Liebert NX UPS, SMS and 1+N multi-module unit with static bypass.....	25
Figure 10	Outline drawing, 225-300kVA Liebert NX, SMS and 1+N multi-module unit with static bypass.....	26
Figure 11	225-300kVA low-voltage cable routing.....	27
Figure 12	Base Drawing, 225-300kVA Liebert NX, SMS and 1+N multi-module unit with static bypass.....	28
Figure 13	Terminal details, 225-300kVA Liebert NX, SMS and 1+N multi-module unit with static bypass.....	29
Figure 14	Terminal details Liebert NX 225kVA - 300kVA UPS 1+N multi-module or SMS .....	29
Figure 15	Main components, 400-600kVA Liebert NX UPS, SMS and 1+N multi-module unit with static bypass.....	30
Figure 16	Outline drawing, 400-600kVA Liebert NX, SMS and 1+N multi-module unit with static bypass.....	31
Figure 17	Base Drawing, 400-600kVA Liebert NX, SMS and 1+N multi-module unit with static bypass ...	32
Figure 18	Terminal details, 400-600kVA Liebert NX, SMS and 1+N multi-module unit with static bypass.....	33

Figure 19 Terminal details Liebert NX 400kVA - 600kVA UPS 1+N multi-module or SMS. .... 34

Figure 20 Recommended control wiring for Liebert NX 225-600kVA single module, Eco Mode ..... 35

Figure 21 Recommended control wiring for Liebert NX 225-600kVA multi-module, Eco Mode. .... 36

## TABLES

Table 1 REPO connection .....13

Table 2 Customizable output contacts .....14

Table 3 Customizable input contacts .....14

Table 4 Battery interface .....15

Table 5 Maintenance bypass key status .....16

Table 6 Maintenance Bypass SKRU Enable .....16

Table 7 Liebert NX UPS specifications ..... 37

Table 8 UPS rating at altitude ..... 38

Table 9 Current ratings—rectifier input ..... 38

Table 10 Current ratings—battery ..... 39

Table 11 Recommended DC circuit breaker rating ..... 39

Table 12 Current ratings—bypass ..... 39

Table 13 Current ratings—output ..... 39

Table 14 Current-versus-time curves of overload capacity ..... 40

Table 15 Recommended conduit and cable sizes .....41

Table 16 Recommended torque values ..... 42

Table 17 Recommended lug sizes ..... 42

Table 18 Components required for seismic configuration meeting OSHPD regulations ..... 43



# IMPORTANT SAFETY INSTRUCTIONS

## SAVE THESE INSTRUCTIONS

This manual contains important instructions that should be followed during installation of your Liebert NX UPS. Read this manual thoroughly, paying special attention to the sections that apply to your installation, before working with the UPS. Retain this manual for use by installing personnel.

### **WARNING**

Risk of electrical shock. Can cause personal injury or death.

This UPS has several circuits that are energized with high DC as well as AC voltages. Check for voltage with both AC and DC voltmeters before working within the UPS. Check for voltage with both AC and DC voltmeters before making contact.

Only properly trained and qualified personnel wearing appropriate safety headgear, gloves, shoes and glasses should be involved in installing the UPS or preparing the UPS for installation. When performing maintenance with any part of the equipment under power, service personnel and test equipment should be standing on rubber mats.

In case of fire involving electrical equipment, use only carbon dioxide fire extinguishers or those approved for use in fighting electrical fires.

Extreme caution is required when performing installation and maintenance.

Special safety precautions are required for procedures involving handling, installation and maintenance of the UPS system. Observe all safety precautions in this manual before handling or installing the UPS system. Observe all precautions in the Operation and Maintenance Manual, SL-25434, before as well as during performance of all maintenance procedures. Observe all DC safety precautions before working on or near the DC system.

### **WARNING**

Risk of heavy unit falling over. Improper handling can cause equipment damage, injury or death.

Exercise extreme care when handling UPS cabinets to avoid equipment damage or injury to personnel. The UPS module weight is up to 4450 lb. (2019kg).

Locate center of gravity symbols and determine unit weight before handling each cabinet. Test lift and balance the cabinets before transporting. Maintain minimum tilt from vertical at all times.

Slots at the base of the module cabinets are intended for forklift use. Base slots will support the unit only if the forks are completely beneath the unit.

Read all of the following instructions before attempting to move, lift, or remove packaging from unit, or prepare unit for installation.



## **WARNING**

Risk of electrical shock and fire. Can cause equipment damage, personal injury or death.  
Under typical operation and with all UPS doors closed, only normal safety precautions are necessary. The area around the UPS system should be kept free of puddles of water, excess moisture and debris. Only test equipment designed for troubleshooting should be used. This is particularly true for oscilloscopes.

Always check with an AC and DC voltmeter to ensure safety before making contact or using tools. Even when the power is turned Off, dangerously high potential electric charges may exist at the capacitor banks and at the DC connections.

All wiring must be installed by a properly trained and qualified electrician.

All power and control wiring must comply with all applicable national, state and local codes.

One person should never work alone, even if all power is disconnected from the equipment. A second person should be standing by to assist and to summon help in case of an accident.

## **WARNING**

Risk of electrical shock and fire. Can cause equipment damage, injury and death.

Internal battery strapping must not be removed. Failure to heed this warning could result in smoke, fire or electric hazard. If strapping is removed, consult your local representative before attempting to transport the battery cabinet.

## **NOTICE**

This unit complies with the limits for a Class A digital device, pursuant to Part 15 Subpart J of FCC rules. These limits provide reasonable protection against harmful interference in a commercial environment. This unit generates uses and radiates radio frequency energy and, if not installed and used in accordance with this instruction manual, may cause harmful interference to radio communications. Operation of this unit in a residential area may cause harmful interference that the user must correct at his own expense.



## **NOTE**

*Materials sold hereunder cannot be used in the patient vicinity (e.g., use where UL, cUL or IEC 60601-1 is required). Medical applications such as invasive procedures and electrical life support equipment are subject to additional terms and conditions.*

# 1.0 MECHANICAL INSTALLATION

## 1.1 INTRODUCTION

This section describes the requirements that must be taken into account when planning the positioning and cabling of the Liebert NX uninterruptible power supply and related equipment.

This chapter is a guide to general procedures and practices that should be observed by the installing personnel. The particular conditions of each site will determine the applicability of such procedures.



### WARNING

Risk of electrical shock. Can cause injury or death.  
Special care must be taken when working with the batteries associated with this equipment. When they are connected together, the battery terminal voltage will exceed 400VDC and is potentially lethal.



### NOTE

*All equipment not referred to in this manual is shipped with details of its own mechanical and electrical installation.*

### NOTICE

Risk of incorrect input power connection. Can cause equipment damage.  
The standard Liebert NX UPS is suitable for connection to three-phase, three-wire plus ground input power.



### NOTE

*Do not apply electrical power to the UPS equipment before the arrival of the commissioning engineer. Connecting power before the commissioning engineer determines the system is properly installed may void the warranty.*

## 1.2 PRELIMINARY CHECKS

Before installing the UPS, please carry out the following preliminary checks:

- Visually examine the UPS equipment for transit damage, both internally and externally. Report any damage to the shipper immediately.
- Verify that the correct equipment is being installed. The equipment supplied has an identification tag on the interior doors reporting the type, size and main calibration parameters of the UPS.
- Verify that the UPS room satisfies the environmental conditions stipulated in the equipment specification, paying particular attention to the ambient temperature and air exchange system.

## 1.3 ENVIRONMENTAL CONSIDERATIONS

### 1.3.1 UPS Room

The UPS module is intended for indoor installation and should be located in a cool, dry, clean-air environment with adequate ventilation to keep the ambient temperature within the specified operating range (see **Environmental Parameters** in **Table 7**).

The Liebert NX UPS is cooled with the aid of internal fans. To permit air to enter and exit and prevent overheating or malfunctioning, do not cover the ventilation openings.

The Liebert NX UPS is equipped with air filters located behind the front doors. A schedule for inspection of the air filters is required. The period between inspections will depend upon environmental conditions.

When bottom entry is used, the conduit plate must be installed.



#### NOTE

*The UPS is suitable for mounting on concrete or other non-combustible surface only.*

#### NOTICE

There is a potential risk to the operational integrity of an installed UPS system by the presence of foreign material inside or in the vicinity of the UPS module.

This risk is especially high if conductive materials find their way inside the UPS module.

The risk potentially involves damage to the installed UPS equipment and subsequent degradation or loss of power to the connected critical site load.

Vertiv applies the highest safety standards in equipment design to ensure that no live parts are exposed to external contact, and also to ensure that the equipment is protected against the introduction of foreign bodies during operation. However, it is not possible for Vertiv to ensure that foreign bodies will not be introduced during on-site installation, or when the UPS doors and covers are “open” and the electrical terminals are exposed to allow power line connections to be made by the electrical contractor/installer.

To prevent major disruption to site operations and risk to property and personnel, including the possibility of a fatality, each site’s facility manager or construction manager must prevent foreign bodies from being introduced into the UPS module.

All UPS modules are thoroughly inspected by Vertiv engineers prior to placement into service and testing on-site.

However, the person responsible for the site must ensure that the UPS module, and the immediate surroundings, are kept clean and free from any possible conductive material such as metal foil, food wrappers, cable shields, washers and other hardware, scrap metal and dust.

If the UPS system is shut down after placement into service and testing are completed, the UPS room must be kept clean to avoid the possibility (during restart) of the considerable volume of air-flow produced by UPS operation to dislodge and/or drag any foreign bodies into the equipment, which would result in system failure and possible supply interruption to the critical site load, and several hours of downtime resulting from the damage typically associated with such events.

If the UPS is left running/operational at the completion of placement into service and testing, the room similarly needs to be kept clean to prevent foreign bodies from entering the UPS module via its forced air-flow.

### 1.3.2 Storing the UPS and Batteries for Delayed Installation

If the Liebert NX system will not be installed immediately, it must be stored indoors in a clean, dry and cool location (see **Environmental Parameters** in **Table 7**). If the UPS includes batteries, either internally or in a battery cabinet, the batteries’ requirements will dictate the storage conditions. Batteries should be unpacked, installed and charged as soon as possible after delivery.

#### NOTICE

Risk of failure to properly charge batteries. Can cause permanent damage to batteries and void the warranty.

Batteries will self-discharge during storage. Batteries must be recharged as recommended by the battery manufacturer. A notice of “Charge Before Date” is affixed to each unit that has batteries inside. The “Charge Before Date” is calculated based on the batteries being stored at 77°F (25°C). Storage at a higher temperature will increase the rate of self-discharge, requiring earlier recharge. Consult the battery manufacturer on how to determine when the batteries need to be recharged.

### 1.3.3 Installation Altitude

The maximum operating altitude of the UPS, without derating, is 3300ft. (1000m). At higher altitudes the load must be reduced according to **Table 8**.

## 1.4 POSITIONING

The cabinet is structurally designed to handle lifting from the base.

Access to the power terminals, auxiliary terminal blocks and power switches is from the front.

The door can be opened to give access to the power connection bars, auxiliary terminal blocks and power isolators. The front door can be opened 90 degrees for more flexibility in installations.

### 1.4.1 Moving the Cabinets

The route to be traveled between the point of arrival and the unit's position must be planned to make sure that all passages are wide enough for the unit and that floors are capable of supporting its weight (for instance, check that doorways, lifts, ramps, etc. are adequate and that there are no impassable corners or changes in the level of corridors).

Ensure that the UPS weight is within the designated surface weight loading (kg/cm<sup>2</sup>) of any handling equipment. For weight details, see **Table 7**.

Move the UPS with a forklift or similar equipment to ease the relocation and to reduce vibration. The optional battery cabinets should be moved with a forklift or similar equipment.

When handling the UPS with a forklift or similar equipment, ensure any lifting equipment used in moving the UPS cabinet has sufficient lifting capacity. When moving the unit by forklift, care must be taken to protect the panels. Do not exceed a 15-degree tilt with the forklift. Bottom structure will support the unit only if the forks are completely beneath the unit.

Handling with straps is not authorized.

## **WARNING**

Risk of heavy unit falling over. Improper handling can cause equipment damage, injury or death.

Because the weight distribution in the cabinet is uneven, use extreme care while handling and transporting. Take extreme care when handling UPS cabinets to avoid equipment damage or injury to personnel.

The UPS module weight is up to 4450 lb. (2019kg).

Locate center of gravity symbols and determine unit weight before handling each cabinet. Test lift and balance the cabinets before transporting. Maintain minimum tilt from vertical at all times.

### 1.4.2 Clearances

The Liebert NX has no ventilation grilles at either side or at the rear of the UPS. Clearance around the front of the equipment should be sufficient to enable free passage of personnel with the doors fully opened. It is important to leave a distance of 24in (610mm) between the top of the UPS and any overhead obstacles to allow the module to be serviced and to permit adequate circulation of air coming out of the unit.

### 1.4.3 Raised-Floor Installations

If the equipment is to be located on a raised floor, it should be mounted on a pedestal suitably designed to accept the equipment point loading. Refer to the base view to design this pedestal.

#### 1.4.4 Kick Plates and Floor Anchors for Special Seismic Certification—Optional

For seismic resistant installations and OSHPD compliance, special floor anchors and kickplates must be used for the UPS and matching battery cabinets; see **Table 18**.

The California Office of Statewide Health Planning and Development (OSHPD) enforces International Building Code requirements for Special Seismic Certification except that the office reduces the required scope of certifications.

#### 1.4.5 Kick Plate Installation—Standard

Kick plates must be installed. If the unit is to be installed in a position that does not permit access to rear kick plates, then the kick plates must be installed before the unit is placed in its final position.

#### 1.4.6 Special Considerations for 1+N Parallel Systems

Consider the grounding configuration of your system before finalizing module placement. See **2.5 - Configuring Ground Connections**.

Vertiv recommends matching the impedance in the bypass path of paralleled systems as closely as possible to ensure good bypass current sharing.

The impedance mismatch can be minimized by controlling the wiring length of each unit. The design and the layout of the UPS system and associated panels and cabling should be examined closely to ensure that cable lengths and impedances are closely matched.

For Liebert NX Systems, the total combined cable length of the bypass feeder cables and the module output cables for each module must be within 5% from maximum to minimum. The combined cable length is the sum of the length from the common source feeding all the modules to the common output switchboard.

If the cabling impedances need to be greater than 5%, contact your Vertiv representative to calculate whether the system will result in an overload condition when operating on bypass.

When bringing the 1+N system on-line for the first time or after removing one unit, Vertiv recommends checking the bypass current mismatch. To check the bypass current mismatch:

1. Place a load on the bypass of each UPS module.
2. View the output current of each unit.

The accuracy of the currents displayed on the UPS module is sufficient for this check. If the mismatch is greater than 5%, the bypass impedances must be balanced or the load must be limited to less than the maximum rating.

The output switchboard for any 1+N system must be configured with one Module Output Circuit Breaker (MOB) for each UPS module that is to be connected to that switchboard. The breaker must be equipped with auxiliary contacts that will be monitored by the UPS in order for interlocks to function properly and for the HMI to indicate the bypassed status of the module.

Vertiv recommends using magnetic or thermomagnetic breakers. If molded case switches will be used, Vertiv recommends installing breakers without electronic trip units or to set the trip units high enough to accommodate high instantaneous currents that may be present when switching a module into an active bus.

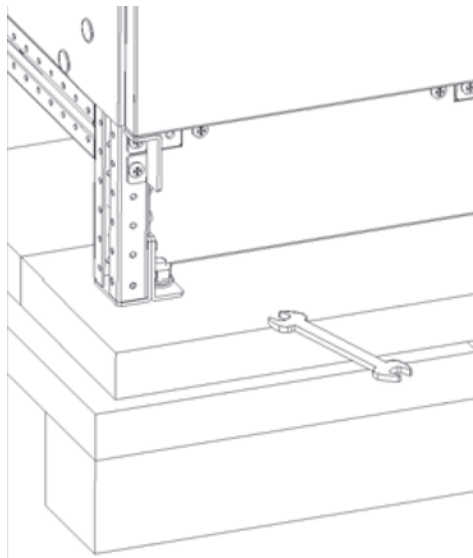
**For 225-250kVA Modules**—Set instantaneous trip settings to allow for 2000A for 2 milliseconds.

**For 400-600kVA Modules**—Set instantaneous trip settings to accommodate 3000A for 2 milliseconds.

### 1.4.7 Unpacking and Unloading the Cabinet from the Pallet

The utmost care must be taken when removing the packaging to prevent damage to the equipment. Check all packaging materials to ensure that no important items are discarded. Once the packaging has been removed, the UPS must be taken off the pallet by removing the retaining screws, as illustrated in **Figure 1**, and lifting the unit off using a fork lift. Do not remove the retaining brackets securing the UPS to the pallet because they are used to fasten the UPS to the floor, except where OSHPD compliance is required and the optional OSHPD seismic anchoring kits are used.

**Figure 1** Unpacking



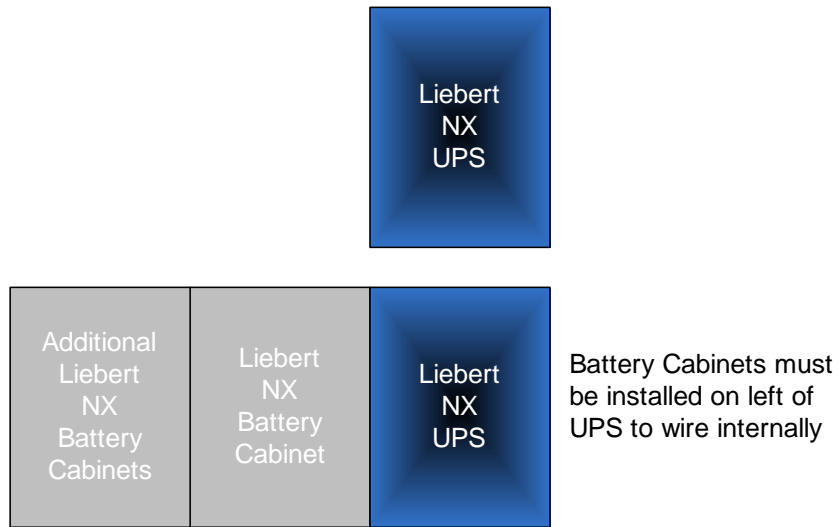
## 1.5 SYSTEM COMPOSITION

A UPS system can comprise a number of equipment cabinets, depending on the individual system design requirements: e.g., UPS cabinet, battery cabinet, maintenance bypass cabinet. In general, all the cabinets used in a particular installation are of the same height. Refer to the drawings provided in **4.0 - Installation Drawings** for the positioning of the cabinets as shown in **Figure 2**.

## 1.6 CABLE ENTRY

Cables can enter the UPS cabinet from bottom or top into the input/output (I/O) section of the unit; see the figures in **4.0 - Installation Drawings**.

**Figure 2 Cabinet arrangement—Liebert NX matching battery cabinets**



If the cabinets are to be bolted together, the side panels must be removed before beginning.

## 2.0 UPS ELECTRICAL INSTALLATION

This chapter provides guidelines for qualified installers who must have knowledge of local wiring practices pertaining to the equipment to be installed.

### **WARNING**

Risk of electrical shock. Can cause injury or death.

The UPS contains high DC as well as AC voltages. Check for voltage with both AC and DC voltmeters before working within the UPS.

Only properly trained and qualified personnel wearing appropriate safety headgear, gloves, shoes and glasses should be involved in installing the UPS or preparing the UPS for installation.

### 2.1 EXTERNAL PROTECTIVE DEVICES

For safety, it is necessary to install circuit breakers in the input AC supply and external battery system. Given that every installation has its own characteristics, this section provides guidelines for qualified installation personnel with knowledge of operating practices, regulatory standards and the equipment to be installed.

External overcurrent protection must be provided. See **Figure 14** for overload capacity.

### 2.2 POWER CABLES

The UPS requires both power and control cabling. All control cables, whether shielded or not, should be run separately from the power cables in metal conduits or metal ducts that are electrically bonded to the metalwork of the cabinets to which they are connected.

The cable design must comply with the voltages and currents in **Tables 9** through **12**, follow local wiring practices and take into consideration the environmental conditions (temperature and physical support media), room temperature and conditions of installation of the cable and system's overload capacity (see **5.0 - Specifications**).

### **WARNING**

Risk of electrical shock. Can cause injury or death.

Before cabling the UPS, ensure that you are aware of the location and operation of the external isolators that connect the UPS input/bypass supply to the power distribution panel.

Check that these supplies are electrically isolated, and post any necessary warning signs to prevent their inadvertent operation.

When sizing battery cables, a maximum volt drop of 2VDC is permissible at the current ratings given in **Table 12**.

The following are guidelines only and are superseded by local regulations and codes of practice where applicable:

- The grounding conductor should be sized according to the fault rating, cable lengths, type of protection, etc. The grounding cable connecting the UPS to the main ground system must follow the most direct route possible.
- Consideration should be given to the use of paralleled smaller cables for heavy currents, as this can ease installation considerably.
- AC and DC cables must be run in conduits according to local codes, national codes and standard best practices. This will prevent creation of excess EMI fields.



## 2.3 SIZING THE INPUT BREAKER FEEDING A LIEBERT NX UPS



### NOTE

See **3.2.3 - Capacity on Demand (Softscale) Upgrades**.

Nominal input current (considered continuous) is based on full-rated output load. Maximum current includes nominal input current and maximum battery recharge current (considered noncontinuous).

Continuous and noncontinuous current are defined in the NEC.

Maximum input current is controlled by the current limit setting, which is adjustable. Values shown are for maximum current limit. If a smaller input feed breaker is used, the input current limit can be adjusted; see your Vertiv representative for more information. The input current limit should not be set less than 105% of the current needed to support the inverter at full load for normal operation.

This results in sufficient power to recharge the battery in a reasonable time and to operate over the published input voltage range.

### 2.3.1 Single or Dual Input Feeds

The Liebert NX 225-600 kVA may be fed from single reference sources or dual asynchronous sources. If a single-input configuration will be used, the utility source must be cabled to the rectifier input busbars. See **Figures 13** and **18**.

### 2.3.2 Automatic Transfer Switches

If the UPS is to be fed from an automatic transfer switch, the transfer switch must have a programmed delay of 100 milliseconds for transfers between two sources.

### 2.3.3 Power Cable Connection Procedure

The rectifier input, bypass, output and battery power cables (all require lug-type terminations) are connected to busbars in the I/O sections (refer to **4.0 - Installation Drawings**).

#### Equipment Ground

The equipment ground busbar is in the I/O sections as shown in (refer to **4.0 - Installation Drawings**). The grounding conductor must be connected to the ground busbar and bonded to each cabinet in the system.

All cabinets and cabling should be grounded in accordance with local regulations.



#### NOTE

*Proper grounding reduces problems in systems caused by electromagnetic interference.*



## WARNING

Failure to follow adequate grounding procedures can result in electric shock hazard to personnel, or the risk of fire, should a ground fault occur.

All operations described in this section must be performed by properly trained and qualified electricians or technical personnel. If any difficulties are encountered, contact Vertiv. See the back page of this manual for contact information.

Once the equipment has been positioned and secured, connect the power cables as described below (refer to the appropriate cable connection drawing in **4.0 - Installation Drawings**):

1. Verify that the UPS equipment is isolated from its external power source and all the UPS power isolators are open.
2. Check that these supplies are electrically isolated and post any necessary warning signs to prevent their inadvertent operation.
3. Open exterior and interior panels on the front of the I/O sections.
4. Connect the ground to the equipment ground busbar located in the I/O sections.
5. Make power connections and tighten the connections to the proper torque.

Ensure correct phase rotation.



## WARNING

Risk of electrical shock. Can cause injury or death.

If the load equipment will not be ready to accept power on the arrival of the commissioning engineer, ensure that the system output cables are safely isolated at their termination.



## WARNING

Risk of electrical shock. Can cause injury or death.

When connecting the cables between the battery extremities to the circuit breaker, always connect the circuit breaker end of the cable first.

6. For control connection details, see **2.4 - Control Cable and Communication**.
7. Close and secure the interior and exterior doors.
8. Attach the kick plates to the bottom of the unit.



#### NOTE

*If the unit is to be installed in a position that does not permit access to rear kick plates, then the kick plates must be installed before the unit is placed in its final position.*

## 2.4 CONTROL CABLE AND COMMUNICATION

Based on your site's specific needs, the UPS may require auxiliary connections to manage the battery system (external battery circuit breaker), communicate with a personal computer or provide alarm signaling to external devices, or for Remote Emergency Power Off (REPO). Refer to **Figures 9** and **15**.

The Liebert NX is equipped with the following interfaces:

- XS3 - Slot for Liebert IntelliSlot™ or ManageUPS™ communication card
- XS6 - Slot for LIFE™ Services modem
- X3 - Reserved
- X6 - Serial interface for external LIFE Services
- XT1/2 - Not Used
- X9 - Reserved
- XT3/8 - 4-pole screw connector for REPO Input and REPO Status
- XT4 - Reserved
- TB1 - 16-pole screw connector for input contacts
- TB2 - 16-pole screw connector for output contacts
- X19A/B - 2x15-pole connectors for parallel UPS connection
- X20 - RJ-45 interface for synchronization with external signal
- XT1 - Not Used
- TB3 - Battery Interface and Key Status
- TB4 - SKRU Enable

### 2.4.1 Slot for Liebert IntelliSlot™ or ManageUPS™ Communication Cards—XS3

This slot is the interface for the Liebert network communication cards. This adapter provides an independent external network interface for communication with network monitoring and building management systems.

Units built since June 2016 are equipped with either the Liebert IntelliSlot system or the ManageUPS system. Previous units included a factory-installed ManageUPS system, which provided connectivity to SNMP and Modbus.

The Liebert IntelliSlot platform includes the Liebert IS-UNITY-DP™ and Liebert IS-485 EXI™ cards. The platform communicates with Vertiv software tools and services, including Trellis®, Liebert SiteScan® Web and Liebert Nform®.

The Liebert IS-UNITY-DP supports up to two third-party protocols along with HTTP/S (Web), Vertiv Protocol, SMTP and SMS.

Third-party protocols available on the Liebert IS-UNITY-DP card are:

- BACnet IP—BACnet over Internet Protocol
- BACnet MSTP—BACnet Master-Slave/Token-Passing (MSTP) communications protocol over an RS-485 serial network (also known as BACnet MSTP RS-485)
- Modbus RTU
- Modbus TCP
- SNMP versions 1, 2c and 3



#### NOTE

*No more than two protocols may be enabled on one card.*

*Only one version of BACnet may be selected, either BACnet IP or BACnet MSTP.*

*Only one version of Modbus may be selected, either Modbus TCP or Modbus RTU.*

*Only one of the protocols can use the 485 port; choosing two 485 protocols will cause conflicts.*

The Liebert IS-485 EXI Card connects to a Liebert SiteLink-E™, allowing Liebert SiteScan Web 4.0 monitoring and control.

Protocols available on the ManageUPS card, depending on the card model, are:

- Modbus RTU—Modbus Remote Terminal Unit (RTU) communication protocol over RS-232, RS-422 and RS-485
- Modbus TCP—Modbus Transmission Control Protocol over Internet Protocol (also known as Modbus TCP/IP)
- SNMP version 1
- Ethernet
- HTTP/Web

#### 2.4.2 Slot for LIFE Services Products—XS6

This slot is the reserved interface for LIFE Services modem card. This card provides an independent external modem interface for communication with LIFE Services service station. Ask your local Vertiv representative for more details on LIFE Services and its benefits for your UPS system.

#### 2.4.3 Serial Interface for Liebert LIFE Services Cards (Serial Input/Output)—X6

The service interface is a SUB-D nine-pin male connector for RS-232 serial communication. It is used for communications with external LIFE Services or other special Liebert applications.

#### 2.4.4 Connector for REPO (Input and Status)—XT3/8

This four-pole screw connector allows:

- Switching off the UPS from a remote source (e.g., push button)
- Providing status to an external system regarding whether the REPO is active

To perform a remote emergency power off, it is necessary to connect an emergency stop button to the UPS via a shielded cable not exceeding 66ft. (20m) in length. The switch must be “Closed” under normal operating conditions and be equipped with a mechanism that maintains it in the “Open” position after it has been pressed. If this button is not installed, a jumper lead must be connected between Pins 1 and 2. For an indication of REPO status, connect Pin 3 and Pin 4 to an external system.

**Table 1 REPO connection**

Pin	Signal	Explanation
1 & 2	REPO Input Contact	REPO active when open
3 & 4	REPO Status Contact	Open when REPO is active

Use 16-22AWG cable.

### **WARNING**

The external push button must be voltage free and isolated from all sources and GND. The external REPO system must not exceed 24V and 20mA.



### **NOTE**

*The external EPO switch must latch open when activated.*

### 2.4.5 Customizable Output—TB2

This 16-pole screw connector allows the connection of six individual configurable output contacts. Each contact is rated for 24VDC 1A. The maximum potential difference between the pins must not exceed 24VDC.

**Table 2 Customizable output contacts**

Pin	Signal	Explanation
1	Normally Closed	Alarm Summary
2	Normally Open	
3	Normally Closed	Bypass Active
4	Normally Open	
5	Normally Closed	Low Battery
6	Normally Open	
7	Normally Closed	AC Fail
8	Normally Open	
9	Common Pins 1-8	
10	Not Available	
11	Normally Closed	Selectable
12	Normally Open	
13	Common Pins 11-12	
14	Normally Closed	Selectable
15	Normally Open	
16	Common Pins 14-15	

Use 16-22AWG cable. The selectable contacts can be customized (by qualified technicians only) to perform various functions.

### 2.4.6 Customizable Input Contact—TB1

This 16-pole screw connector allows the connection of four individual configurable input contacts. Each contact is rated for 24VDC 1A. The maximum potential difference between the pins must not exceed 24VDC.

**Table 3 Customizable input contacts**

Pin	Signal	Explanation
1	Input #1 (24VDC out)	Selectable <sup>1</sup>
2	Input #1 (24VDC signal)	
3	Input #2 (24VDC out)	Selectable <sup>2</sup>
4	Input #2 (24VDC signal)	
5	Input #3 (24VDC out)	Selectable
6	Input #3 (24VDC signal)	
7	Input #4 (24VDC out)	Selectable
8	Input #4 (24VDC signal)	
9-16	Common Pins 1-8	Not Available

1. This contact is used for the MBB auxiliary contacts. See **Figure 5**.
2. For 1+N systems, the auxiliary contacts for the MOB breaker must be connected to these inputs. See **Figure 5**. A shorting switch may be connected here for Load Bank Breaker/Testing.

Use 16-22AWG cable. All input contacts can be programmed using service software.



To drive the inputs, use no-voltage contacts. Do not use voltages supplied by external power supply.

### 2.4.7 Contact Control for Eco Mode

An active economizer Eco Mode is enabled on the Liebert NX 225-600kVA UPS. The mode is incorporated in all single-module systems and in multi-module (distributed bypass) units with Firmware Version 1.04 or newer.

For details on Eco Mode operation, refer to the Liebert NX operation manual, SL-25354, available at the Liebert Web site: [www.liebert.com](http://www.liebert.com). See **Figures 20** and **21** for recommended wiring layout.

Eco Mode must be set up by an Vertiv Liebert Services customer engineer. Once set up, Eco Mode becomes the default operating mode: It shifts the load to bypass if utility power is within specified limits and to double-conversion (on-line) mode if utility power falls outside the limits.

The UPS can be set up so that Eco Mode can be activated and deactivated by the operator. A Liebert Services engineer must program an input contact to suppress Eco Mode. A key switch or other device, supplied and installed by others, can be used to provide the signal that deactivates Eco Mode to the input contact. Operating the key switch (or other device) allows the UPS to return to Eco Mode as its default mode of operation. Contact Liebert Services for details.

Additionally, a standby generator mode is available that may be activated by a contact closure (typically from the generator). This mode shuts Off battery charging and brings the UPS out of Eco Mode while the generator is providing the power.

### 2.4.8 Connector for Parallel UPS Connection—X19A, X19B

This interface is used for paralleling two or more UPS's with each other.

### 2.4.9 RJ-45 Interface for Synchronization with External Signal—X20

This interface is used to communicate with an external synchronization device, such as Load Bus Sync Module (for two modules only) or the Multibus Sync Module (for up to 11 modules). See the manuals related to these options for more details.

The interface can be used to synchronize the outputs of multiple UPS devices, even when they do not have a common output. This enables an external static switching device to commutate between UPS outputs in the event of a malfunction, without creating synchronization problems.

### 2.4.10 UPS Control Contacts with Battery Cabinet or Module Battery Disconnect

These contacts are used to communicate between the UPS module and Battery cabinets or Module Battery Disconnects.

**Table 4 Battery interface**

Terminal Block	Pin	Connects to (Description of External Item)
TB3	1	Battery Interface Board TB1154-1
	2	Battery Interface Board TB1154-2
	3	Battery Interface Board TB1154-3
	4	Battery Interface Board TB1154-4

Use Belden 9156 equivalent wire. Total length of cable from UPS to all battery interface connections must be less than 1000ft (300m).

### 2.4.11 UPS Control Contacts with Global Maintenance Bypass

These contacts are used to communicate between the UPS module and Maintenance Bypass.

**Table 5 Maintenance bypass key status**

Terminal Block	Pin	Description
TB3	5	Key status switch, closed = key inserted
	6	Key status switch, common
	7	Key status switch, closed = key removed

1. See 2.6 - Distributed Static Switch (1+N) System Cabling Layouts for 1+N systems with a Maintenance Bypass.
2. Key Status Input must be Form-C contact.

Use 14AWG cable wire up to 500ft. (150m).

**Table 6 Maintenance Bypass SKRU Enable**

Terminal Block	Pin	Description
TB4	1	Maintenance Bypass Cabinet, closed = load not on inverter
	2	Maintenance Bypass Cabinet, common
	3	Maintenance Bypass Cabinet, closed = load on inverter

1. For 1+N systems with a maintenance Bypass, these contacts must be run to each module from an isolated source.
2. These contacts must be run separately from all other control cables.

Use 14AWG cable wire up to 500ft. (150m)

## 2.5 CONFIGURING GROUND CONNECTIONS

Liebert NX 225-600kVA is compatible with solidly grounded wye sources or a high resistance ground system, if compatible. Refer to **2.5.3 - High-Resistance Ground Systems**.



### NOTE

*Early production models may not be compatible with high-resistance ground systems.*

Improper grounding is the largest single cause of UPS installation and startup problems. Grounding techniques vary significantly from site to site, depending on several factors.

Proper grounding should be based on the appropriate NEC sections, but safe and proper equipment operation requires further enhancements. The following pages detail recommendations for grounding various system configurations to ensure optimal UPS system performance.



## CAUTION

The UPS ground lug must be solidly connected to the service entrance ground by an appropriately sized wire conductor per the NEC.

Each conduit or raceway containing phase conductors must also contain a ground wire, both for UPS input and output, which are solidly connected to the ground terminal at each termination point.

Conduit-based grounding systems tend to degrade over time. Therefore, using conduit as a grounding conductor for UPS applications may degrade UPS performance and cause improper UPS operation.

### 2.5.1 Three-Wire Input Connections

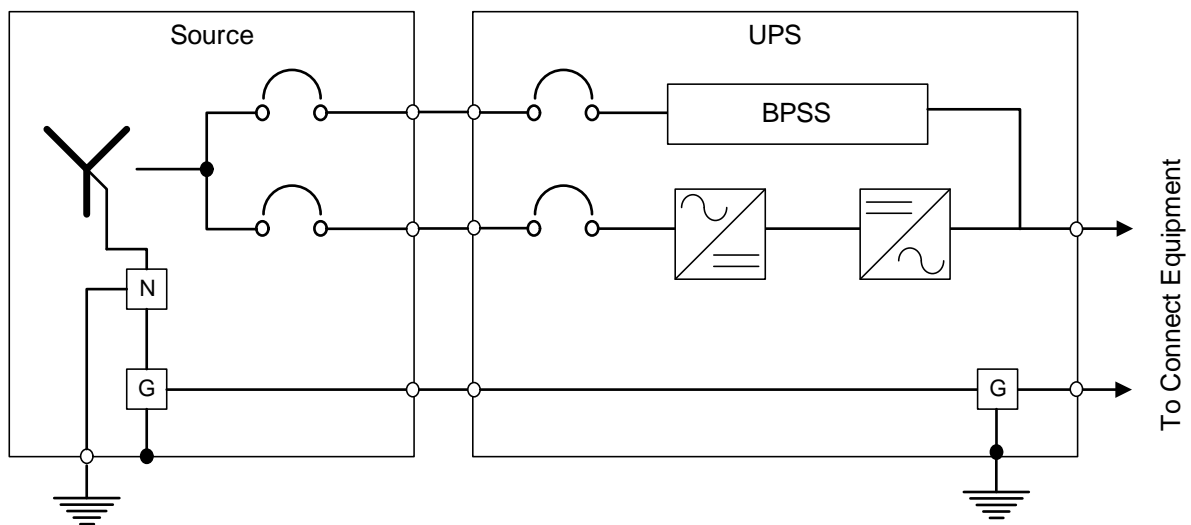
This configuration must NOT be used when single-phase loads are directly connected to the UPS. Please note that whenever the UPS module transfers to or from bypass, two AC sources (UPS output and bypass) are briefly connected together and circulating current must flow. In this configuration, the current flows through the ground path, possibly tripping ground fault interrupters (GFI's) and distorting the output voltage waveform. Proper adjustment of ground fault interrupters is necessary to avoid unwanted tripping. The time delay should be set to at least 0.2 seconds to prevent tripping when the UPS performs a transfer or retransfer operation.

#### NOTICE

Risk of improper installation. Can cause equipment damage.

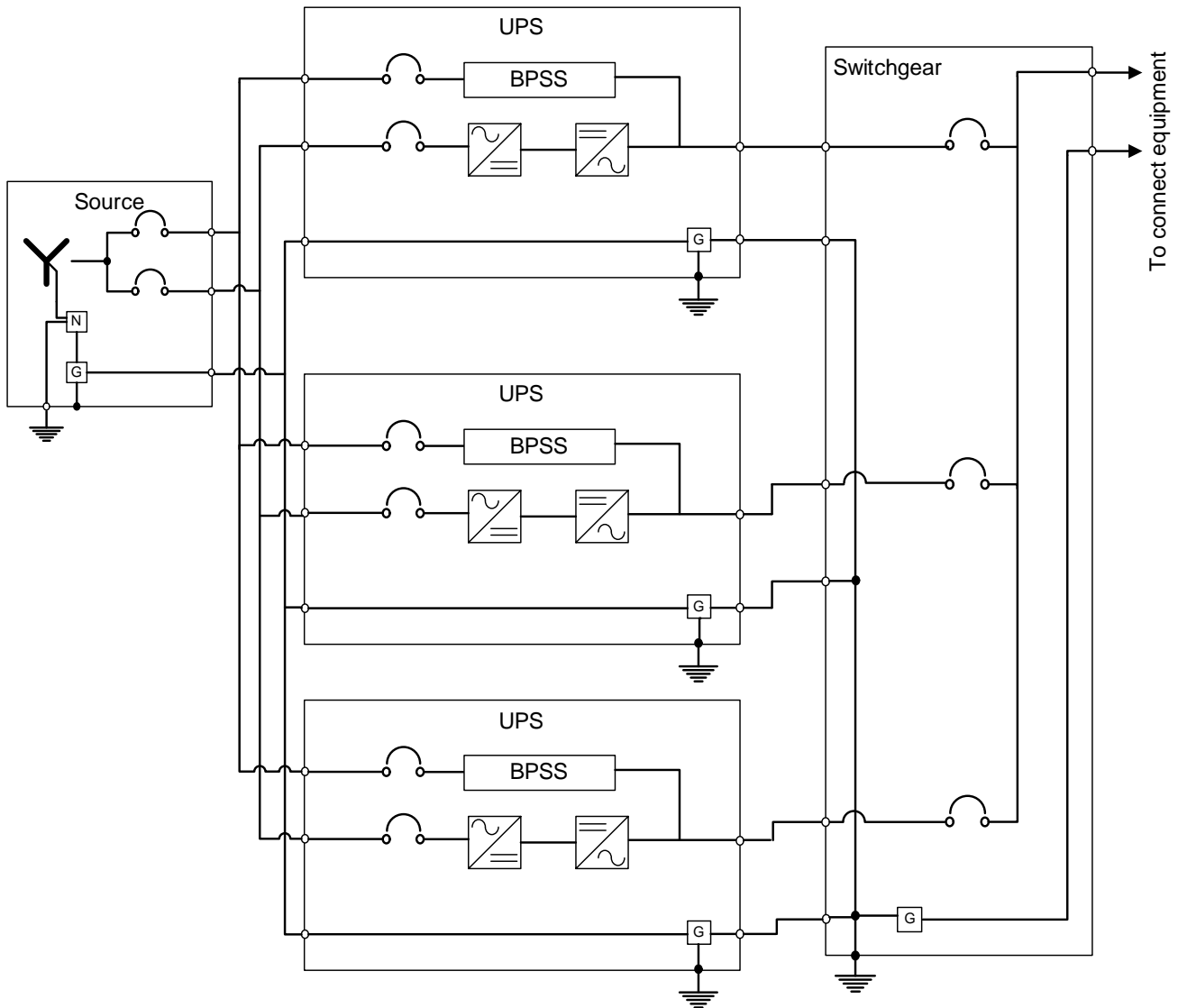
Failure to set the ground fault interrupters properly could cause loss of power to the critical load.

**Figure 3** Grounding diagram—Three-wire single-module systems





**Figure 4** Grounding diagram—Three-wire multi-module systems



### 2.5.2 Preferred Grounding Configuration, Battery Systems

Battery cabinet systems must be connected as floating (ungrounded) systems.

Center-tapped or grounded battery systems are not possible with battery cabinet systems.

Whether the battery system is open-rack or cabinet, the metal rack parts or cabinet must be grounded to the UPS module ground bus.

### 2.5.3 High-Resistance Ground Systems

Liebert NX 400-600kVA units produced on or after August 1, 2013, with serial numbers as indicated below, are compatible with High Resistance Ground (HRG) applications. Earlier production units may NOT be compatible with HRG application and may either bear no label or be specifically labeled as not compatible. If the Liebert NX UPS is NOT labeled as either compatible or not compatible, contact the factory before installing the unit in an HRG application.

#### Liebert NX Serial Numbers/Compatibility with High Resistance Ground

NX 225-600 kVA serial numbers are structured as follows:

**21**    **XXXXXXXX**    **138**    **X XX XXXX**

(Digits 12, 13 and 14 are underlined above)

**Digits 12 and 13** of the serial number represent the year of production

Example—*13* = calendar year 2013; *14* would represent calendar year 2014.

**Digits 1 and 3** represent the month

Example—*1-9* = January-September, A = October, B = November, C = December  
(e.g. *138* = August 2013, *13C* = December 2013)

HRG compatibility was instituted for Liebert NX 400-600kVA units effective August 1, 2013, so serial numbers with Digits 12,13 and 14 of *138* or higher designate Liebert NX 400-600kVA units that have HRG compatibility. Contact the factory for HRG compatibility for Liebert NX 225-300kVA units.

## 2.6 DISTRIBUTED STATIC SWITCH (1+N) SYSTEM CABLING LAYOUTS

The output switchboard for a 1+N system must be configured with one Module Output Circuit Breaker (MOB) for each UPS module to be connected to that switchboard. The breaker must be equipped with auxiliary contacts that will be monitored by the UPS so that interlocks will function properly and for the HMI to indicate the bypassed status of the module. Vertiv recommends using magnetic or thermomagnetic breakers. If molded case switches will be used, Vertiv recommends installing breakers without electronic trip units or to set the trip units as follows:

- **For 225-300kVA Modules:** 2000A for 2 milliseconds
- **For 400-600kVA Modules:** 3000A for 2 milliseconds.

Figure 5 System layout, 1+N

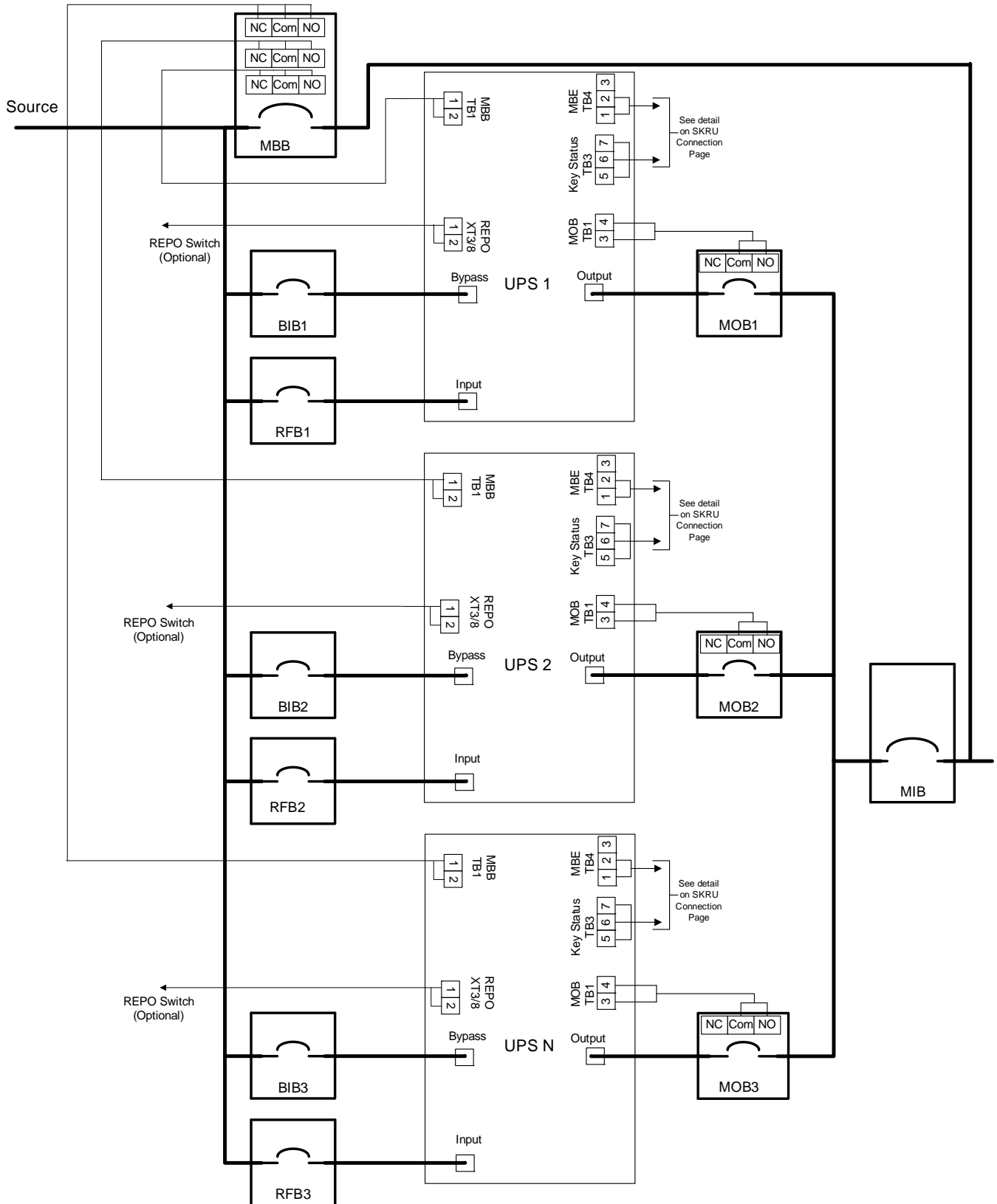


Figure 6 SKRU connections

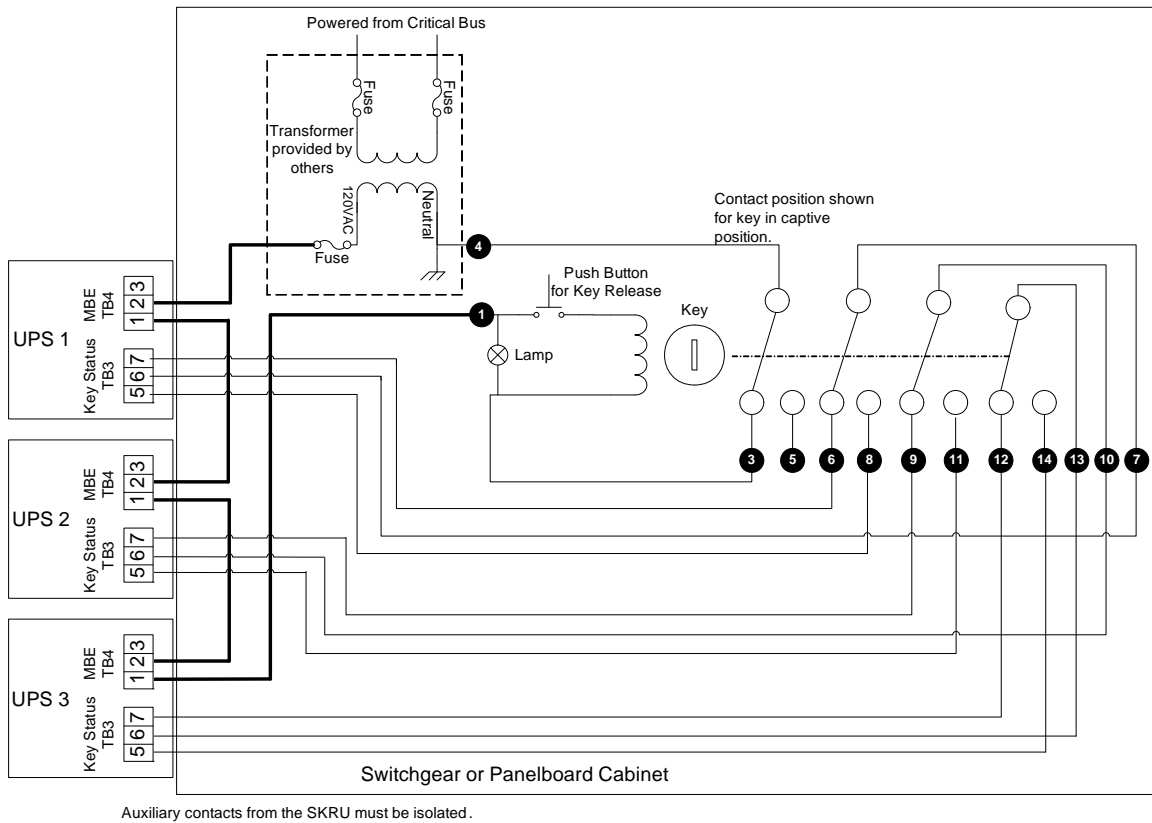
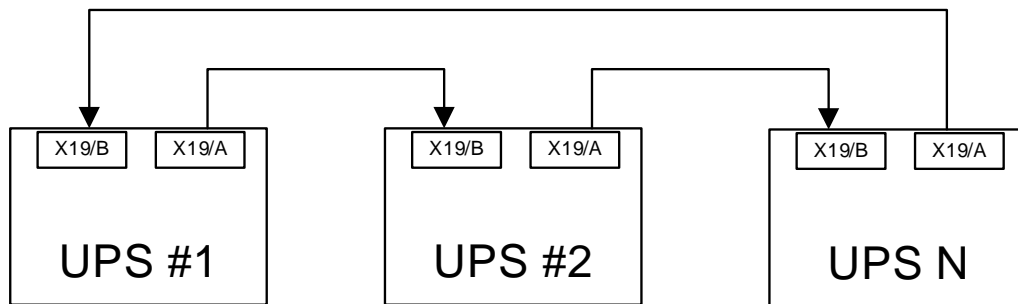
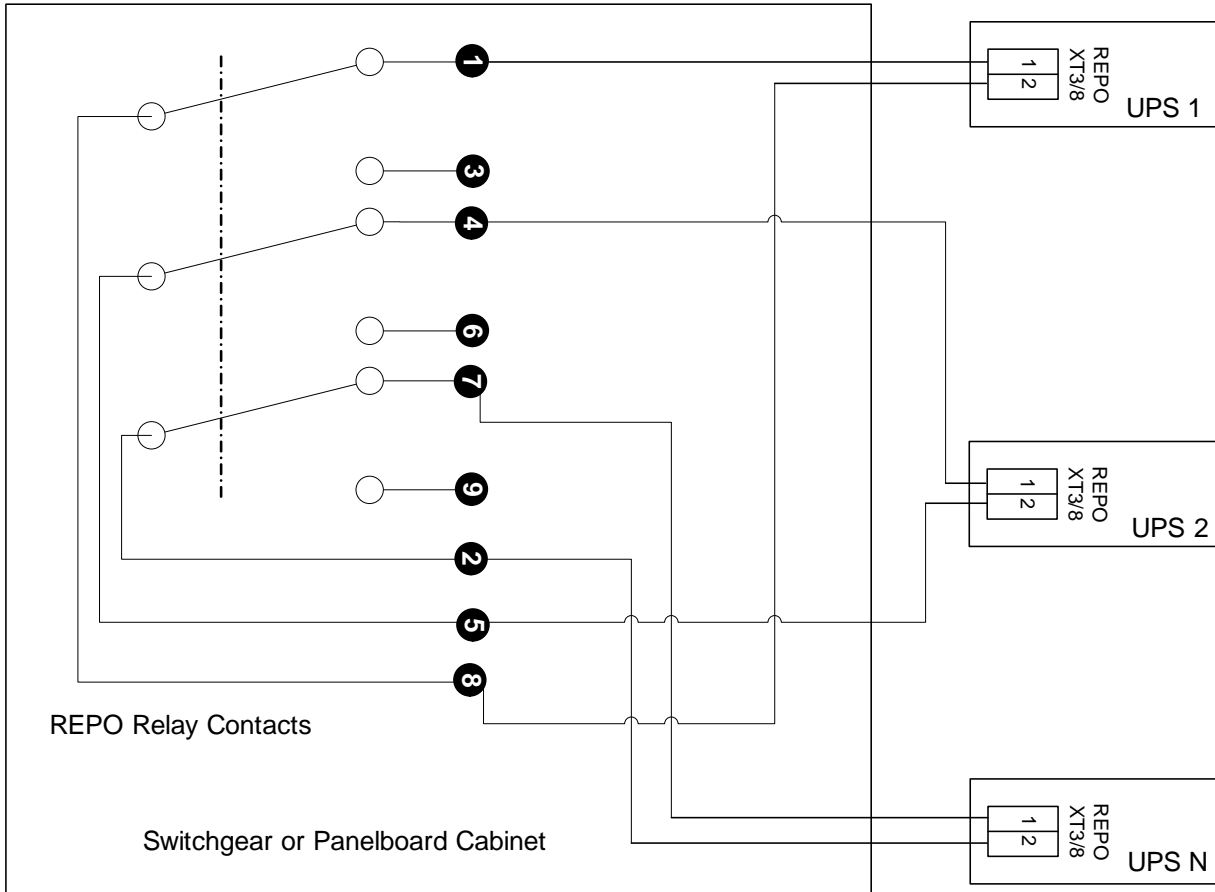


Figure 7 Control wiring



**Figure 8 REPO connections 1+N system**



All auxilliary contacts from the REPO must be isolated.

## 3.0 OPTIONAL EQUIPMENT

### 3.1 SINGLE-MODULE SYSTEM OPTIONS

#### 3.1.1 Input Circuit Breaker

The input circuit breaker, which feeds the rectifier, is a option because some configurations may not require this if a maintenance bypass with a rectifier input breaker is located close to the UPS module

#### 3.1.2 External Battery Temperature Sensor—Optional

For systems that do not use Liebert NX Battery Cabinets, an optional temperature sensor can be installed to monitor the battery cabinet or ambient room temperature. This sensor is connected to the BIB board. This sensor will allow the Liebert NX UPS to perform temperature compensation charging.

#### 3.1.3 Matching Liebert NX Battery Cabinet

The optional matching Liebert NX Battery Cabinet can be used to obtain the desired autonomy time. The battery cabinets are designed to be either attached to the UPS or separate from the UPS (for details, see the Liebert NX Battery Cabinet installation manual, SL-25430, available at Liebert's Web site: [www.liebert.com](http://www.liebert.com))

#### 3.1.4 Battery Interface Box

The battery interface box contains a battery interface board. The battery interface box is required when an NX 225-600kVA UPS is installed with any non-Liebert battery cabinet, non-matching MBD or Battery Isolation Switch (BIS).

One battery interface box is required for each non-Liebert battery cabinet, MBD or BIS.

#### 3.1.5 Local EPO Button

A local EPO button with protective cover is available. This option is typically installed at the factory but may be field-installed by Liebert Services.

### 3.2 COMMUNICATION AND MONITORING

- Liebert IS-UNITY-DP™ card, supports any two of the following: BACnet IP; BACnet MSTP; Modbus RTU; Modbus TCP; and SNMP versions 1, 2c and 3
- Liebert IS-485 EXI™ card connects to Liebert SiteLink-E for Liebert SiteScan® Web monitoring
- ManageUPS™ card: SNMP v1, Ethernet, HTTP/Web; Modbus RTU and Modbus TCP.

#### 3.2.1 Remote Status Panel

Available as surface mount. The power supply for the remote status panel is factory-installed in the UPS module and must be ordered with the unit.

#### 3.2.2 Alber Monitoring System

The matching Liebert NX Battery Cabinet allows installing an optional Alber® battery monitoring system in the cabinet. The Alber battery monitoring by Liebert continuously checks all critical battery parameters, such as cell voltage, overall string voltage, current and temperature. Automatic periodic tests of internal resistance of each battery will verify the battery's operating integrity.

Additional capabilities include automatic internal DC resistance tests and trend analysis, providing the ability to analyze performance and aid in troubleshooting.

#### 3.2.3 Capacity on Demand (Softscale) Upgrades

Modules that were ordered and installed as Capacity on Demand soft-scalable modules can be upgraded to either full 300kVA/KW (from 225 or 250kVA/kW) or 600kVA KW(400 and 500kVA/kW). If this upgrade is planned, breakers and conductors should be sized for the final capacity.

### **3.3 MULTI-MODULE SYSTEM OPTIONS AND ACCESSORIES**

The accessories and options listed in sections **3.1** through **3.2.1** may be applied to the individual modules in a multi-module (1+N) system or a synchronized dual bus (2N) system.

#### **3.3.1 Paralleling Cable Kit**

A DB-15 module-to-module communication cable is required for 1+N parallel systems. A kit with two cables, each 82ft. (25m) long, is available. At least one kit is required for each add-on UPS module; the number of kits required is one fewer than the number of UPS modules in the 1+N system (e.g., six UPS modules would require five kits).

#### **3.3.2 Load Bus Sync Controller**

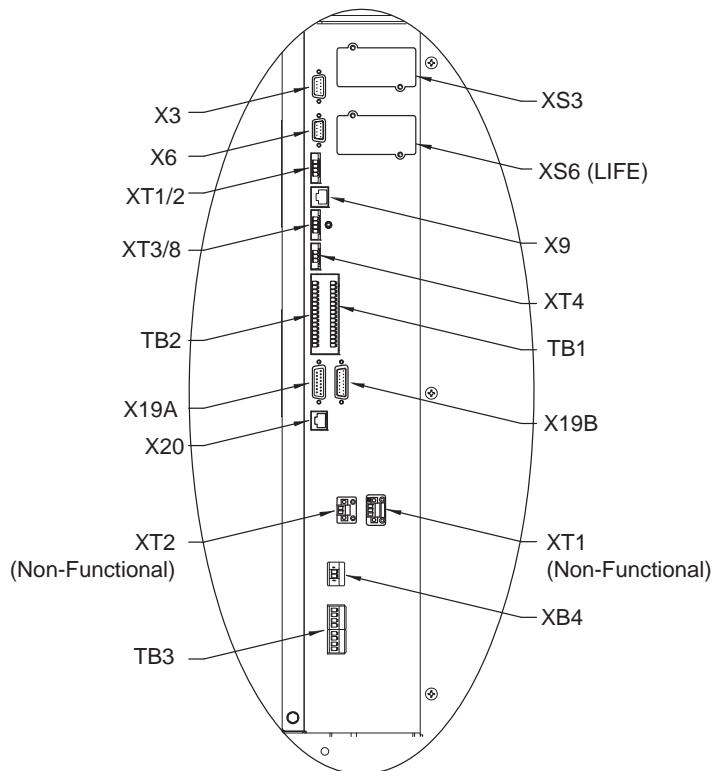
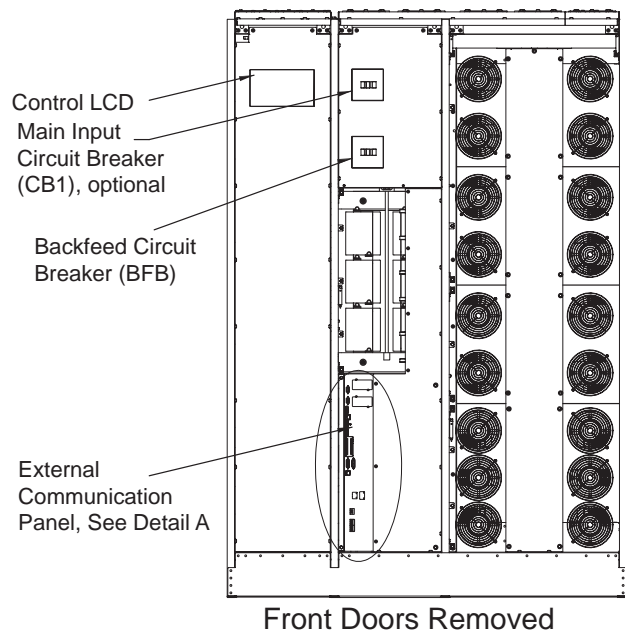
Distributes common reference synchronization signal for up to two Liebert NX 225-600 UPS modules. A typical installation would have two modules synchronized to a common bypass line.

#### **3.3.3 Multi-Bus Synch Module (MBSM)**

This module is available to support up six or up to 11 UPS modules, and is generally configured to synchronize all modules to a reference bus (e.g., bypass line). See the manual for this module for more details.

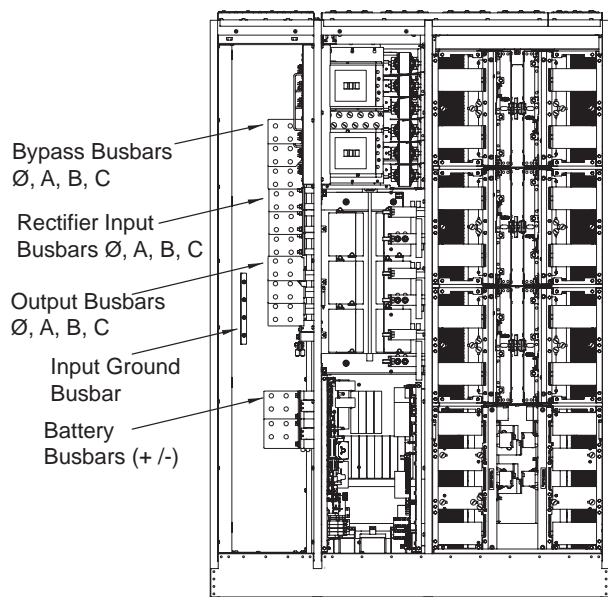
# 4.0 INSTALLATION DRAWINGS

Figure 9 Main components, 225-300kVA Liebert NX UPS, SMS and 1+N multi-module unit with static bypass



Detail A

External Communication Panel  
(See specific control wiring drawings)

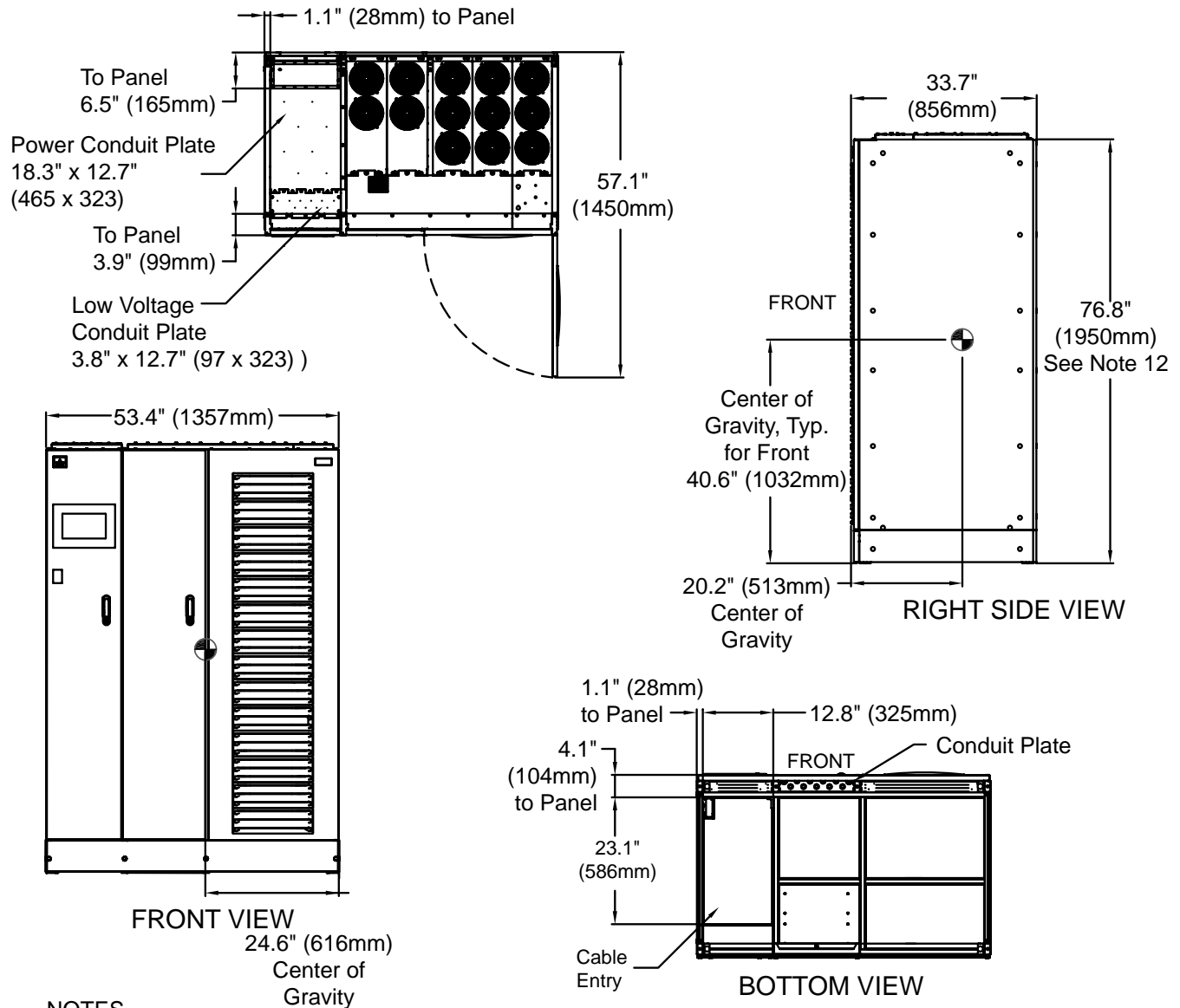


Doors and Inner Skins Removed

U38-3C-2000  
Rev. 2



**Figure 10 Outline drawing, 225-300kVA Liebert NX, SMS and 1+N multi-module unit with static bypass**

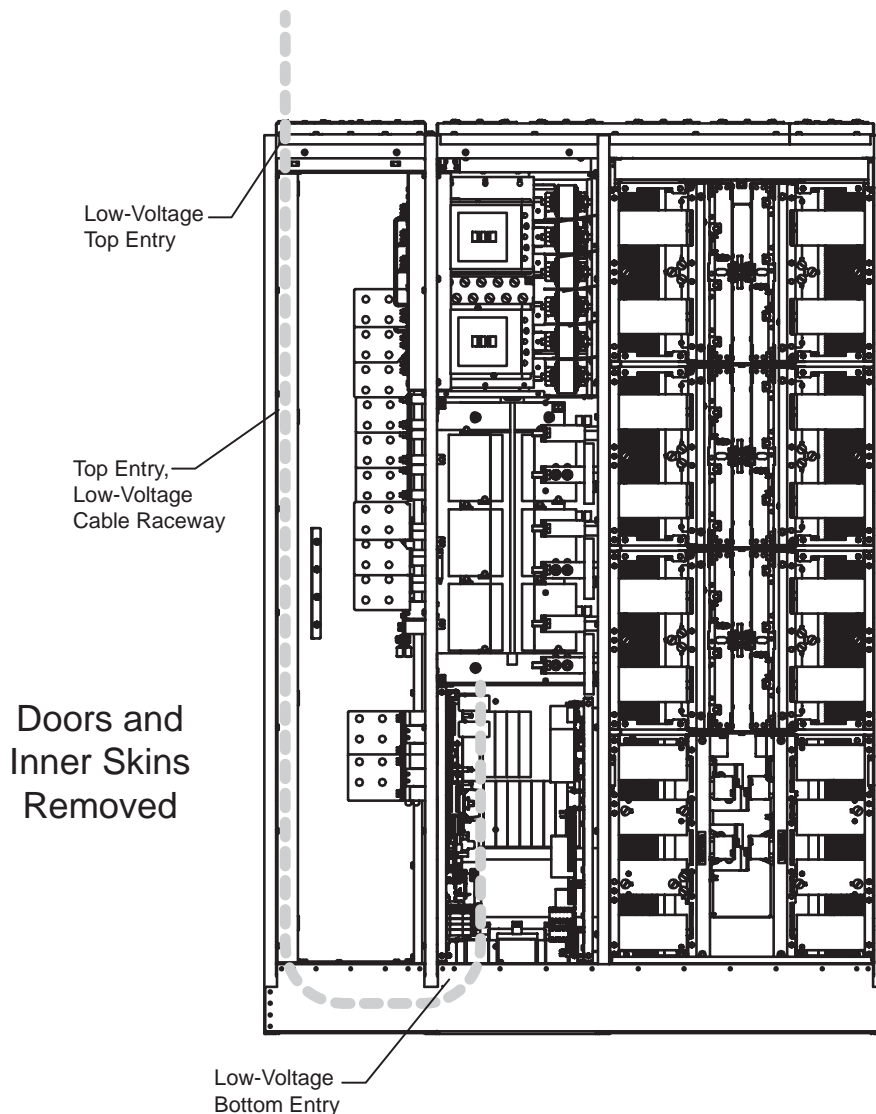


**NOTES**

1. All dimensions are in inches (mm).
2. 24" (610) minimum clearance above unit required for air exhaust and 36" (914) front access required for service.
3. Keep cabinet within 15 degrees of vertical.
4. Top and bottom cable entry available through removable access plates. Remove, punch to suit cable entry size and replace.
5. Unit bottom is structurally adequate for forklift handling.
6. Control wiring and power wiring must be run in separate cable entry.
7. All wiring is to be in accordance with national and local electrical codes.
8. Depth dimension includes front door and rear panel.
9. Width dimensions include side panels.
10. See technical data drawing for shipping weights.
11. The height is to the top of the frame; fans rise 1.5" (38.1mm) above the frame.

U38-3C-2001  
Rev. 4

Figure 11 225-300kVA low-voltage cable routing

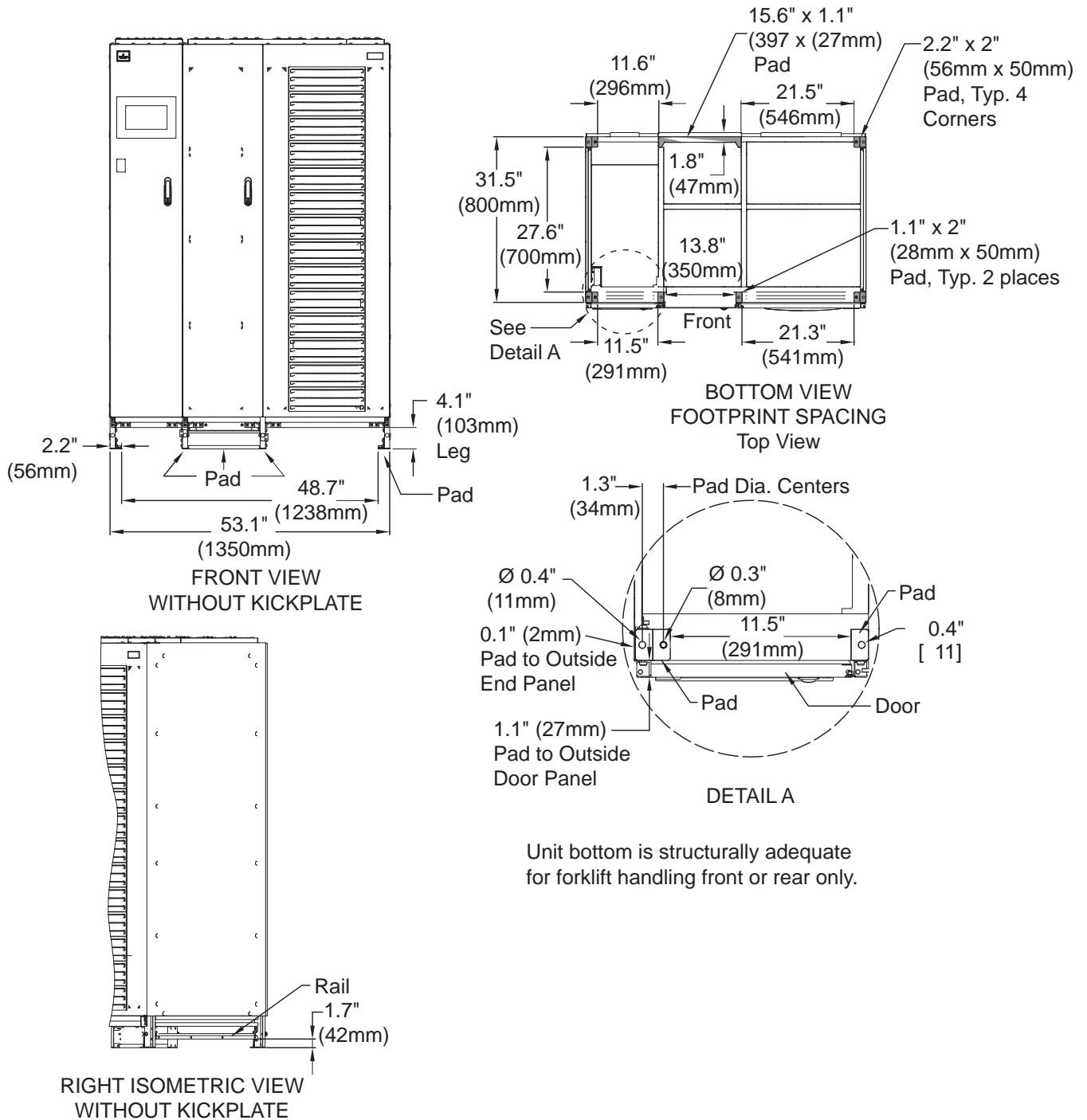


**NOTE**

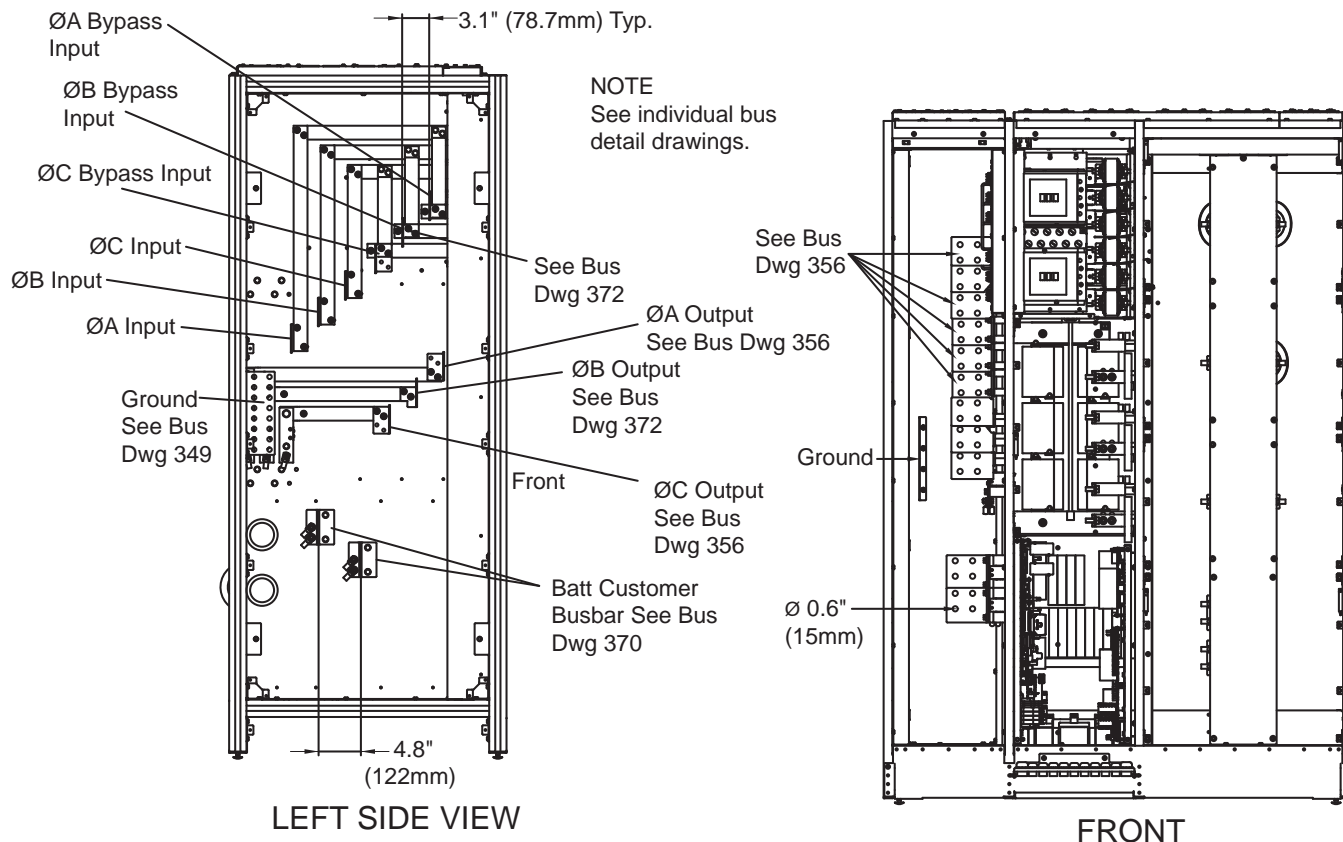
Remove the low-voltage control wire plate (at the top of the unit and then expose the area by removing the inside cover plate), punch the conduit holes, land the conduit, and then route the control wire to the “chimney stack” toward the bottom of the unit.

Run the control wires to through the conduit plate provided. If the unit is not on a raised floor, then insert a rubber grommet into the conduit plate hole (at the bottom of the entry location for the low-voltage control wiring).

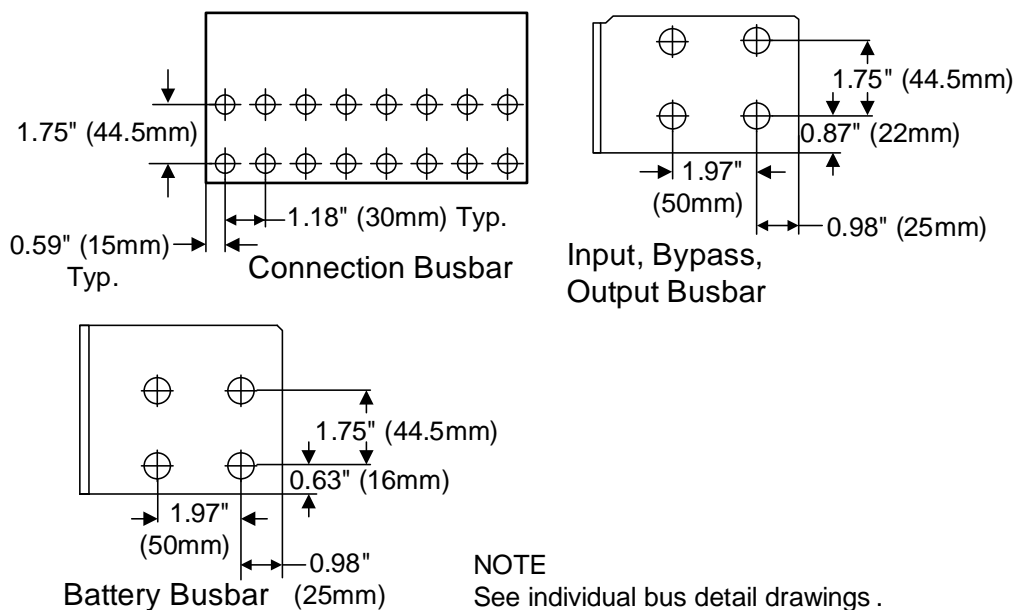
**Figure 12 Base Drawing, 225-300kVA Liebert NX, SMS and 1+N multi-module unit with static bypass**



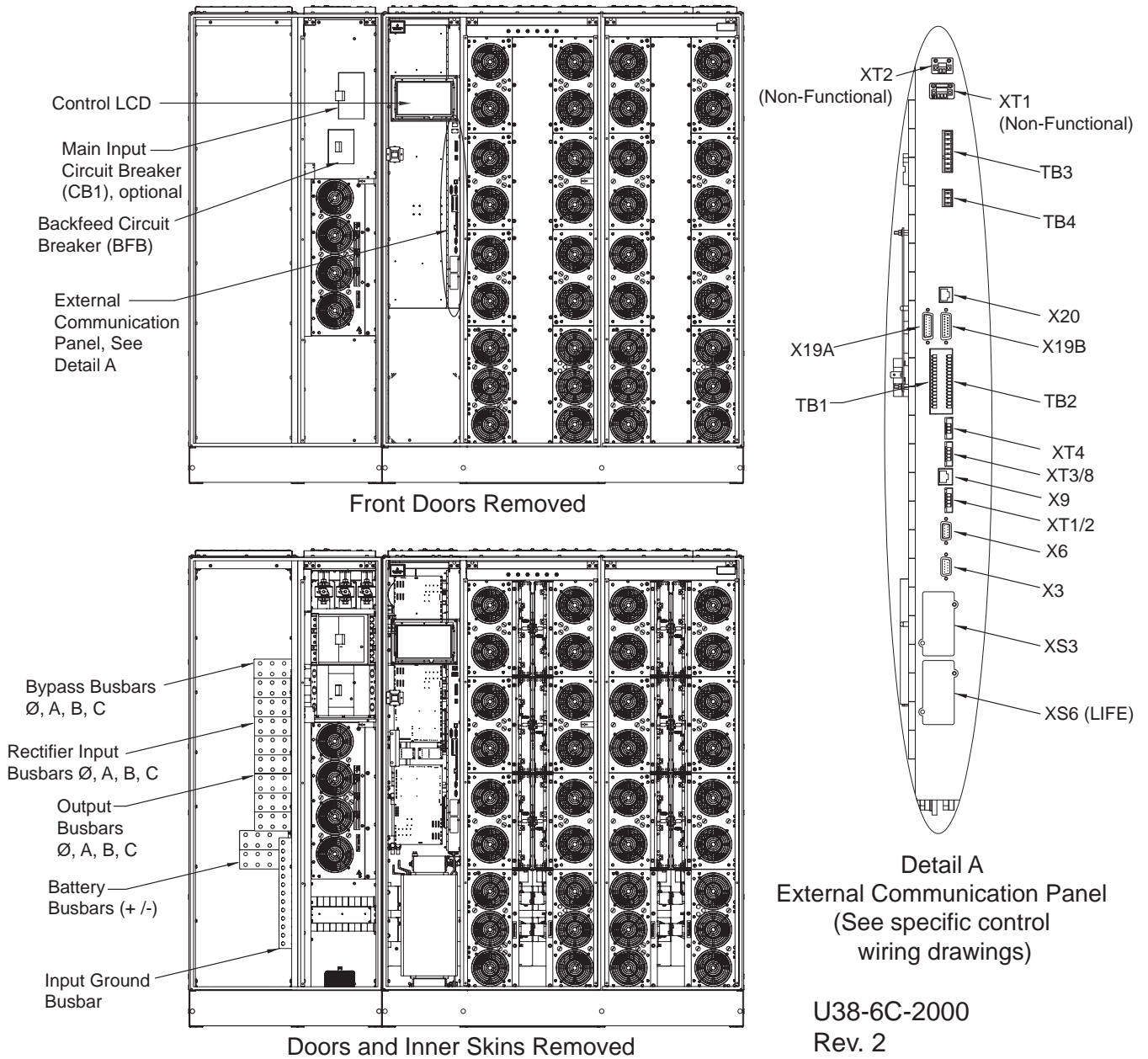
**Figure 13 Terminal details, 225-300kVA Liebert NX, SMS and 1+N multi-module unit with static bypass**



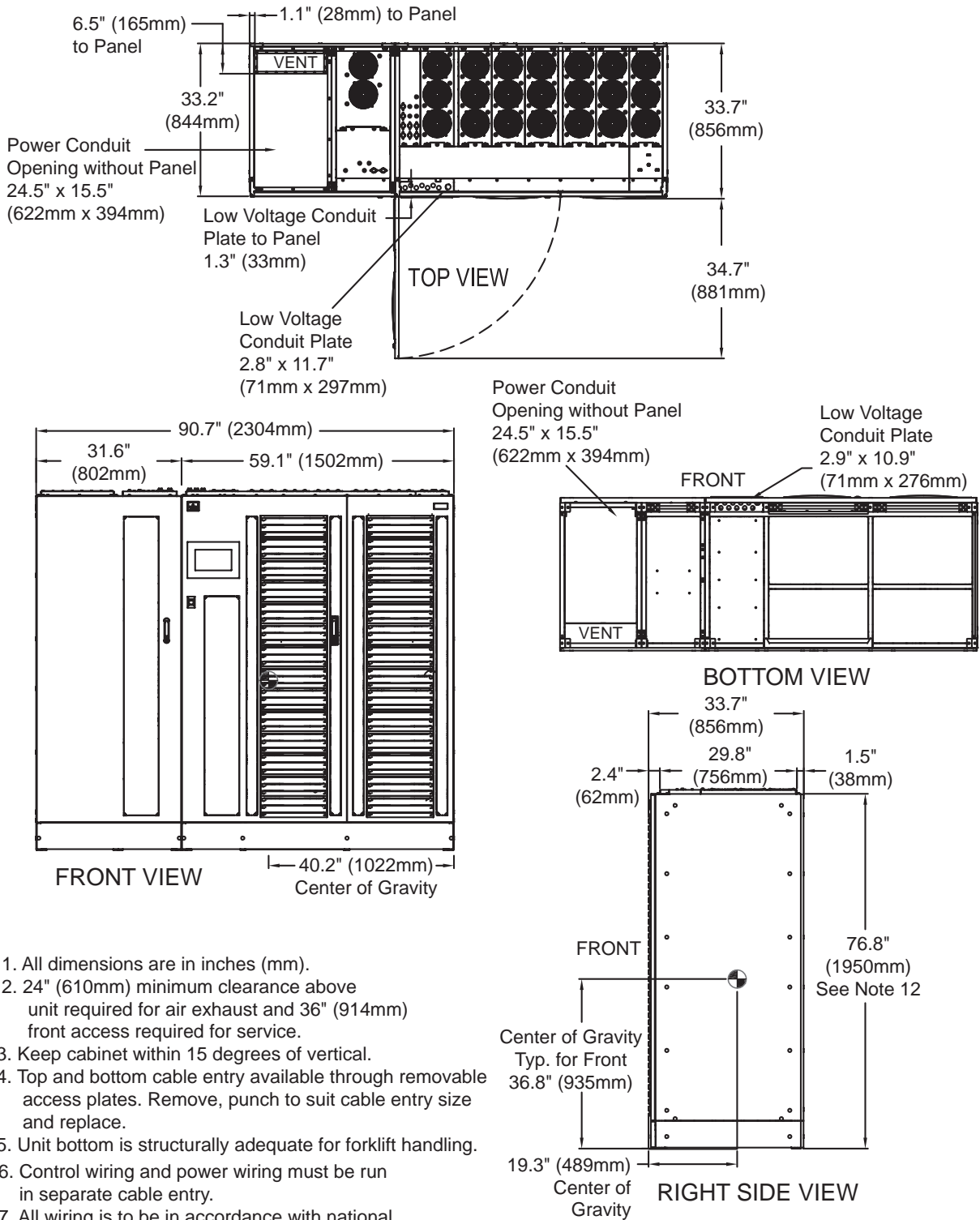
**Figure 14 Terminal details Liebert NX 225kVA - 300kVA UPS 1+N multi-module or SMS**



**Figure 15 Main components, 400-600kVA Liebert NX UPS, SMS and 1+N multi-module unit with static bypass**



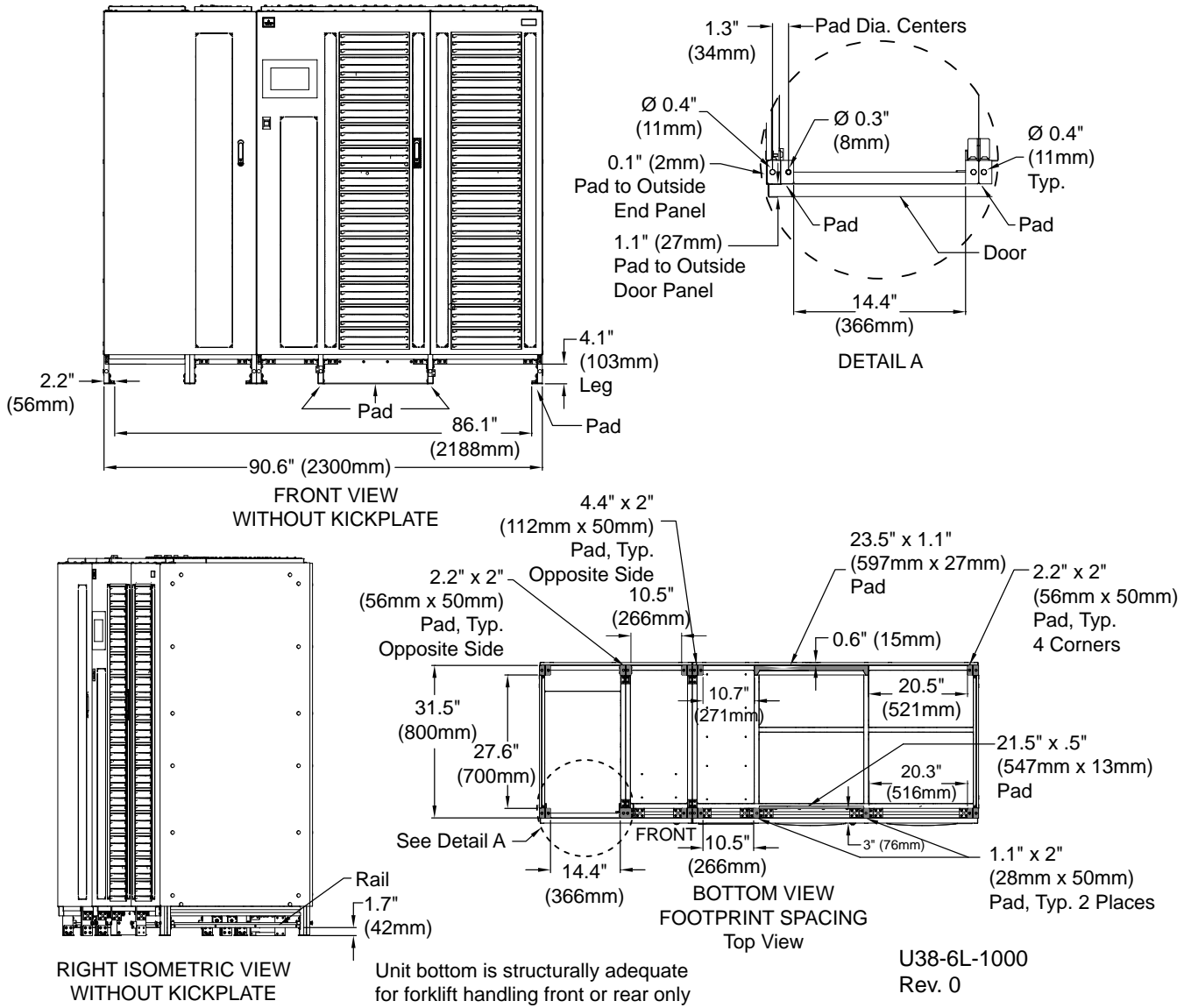
**Figure 16 Outline drawing, 400-600kVA Liebert NX, SMS and 1+N multi-module unit with static bypass**



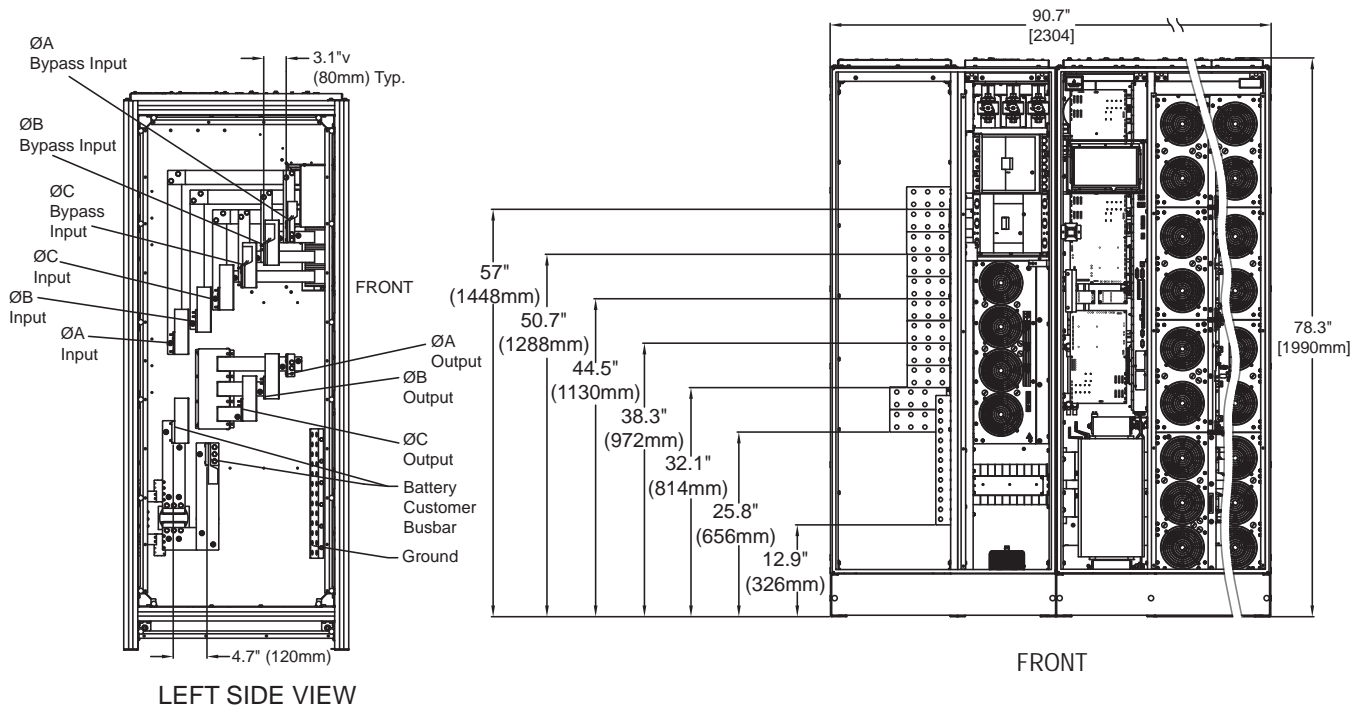
1. All dimensions are in inches (mm).
2. 24" (610mm) minimum clearance above unit required for air exhaust and 36" (914mm) front access required for service.
3. Keep cabinet within 15 degrees of vertical.
4. Top and bottom cable entry available through removable access plates. Remove, punch to suit cable entry size and replace.
5. Unit bottom is structurally adequate for forklift handling.
6. Control wiring and power wiring must be run in separate cable entry.
7. All wiring is to be in accordance with national and local electrical codes.
8. Depth dimension includes front door and rear panel.
10. Width dimensions include side panels.
11. See technical data drawing for shipping weights.
11. The height is to the top of the frame; fans rise 1.5" (38mm) above the frame.

U38-6C-2001  
Rev. 5

**Figure 17 Base Drawing, 400-600kVA Liebert NX, SMS and 1+N multi-module unit with static bypass**

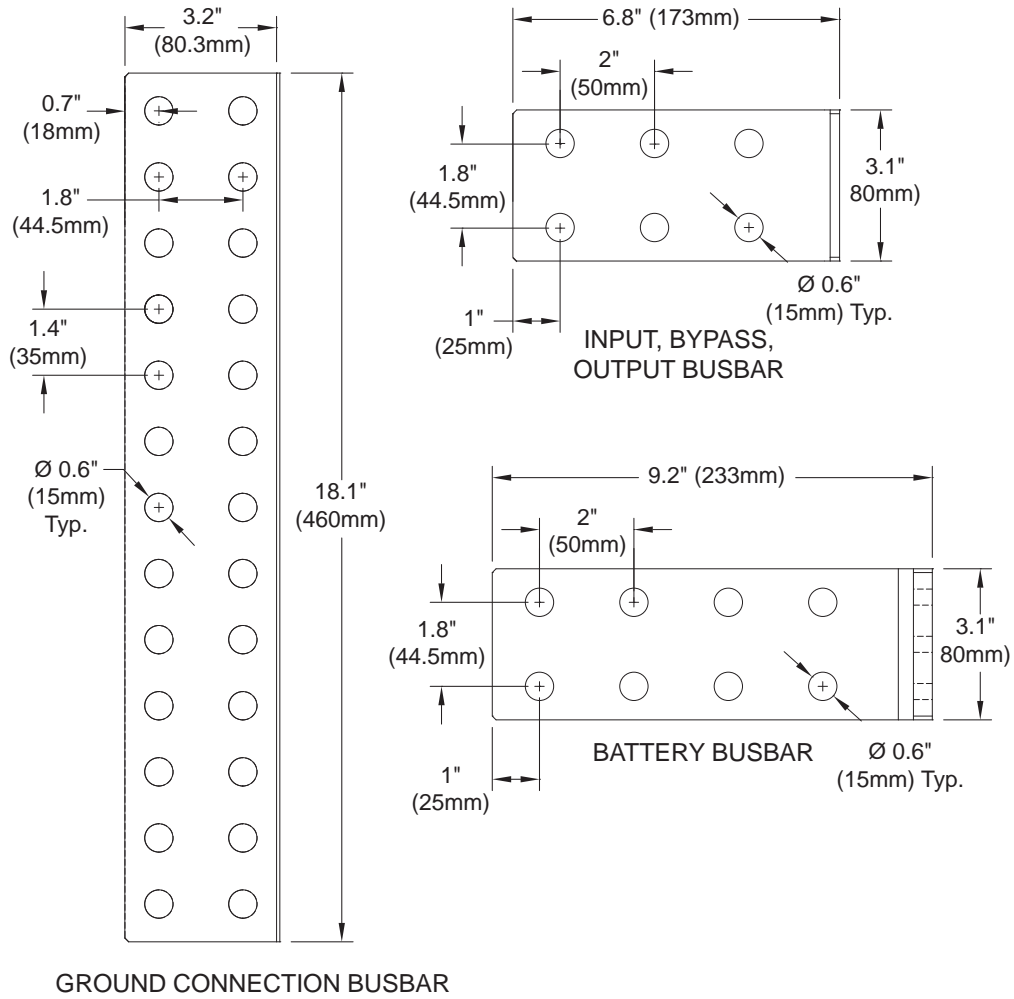


**Figure 18 Terminal details, 400-600kVA Liebert NX, SMS and 1+N multi-module unit with static bypass**



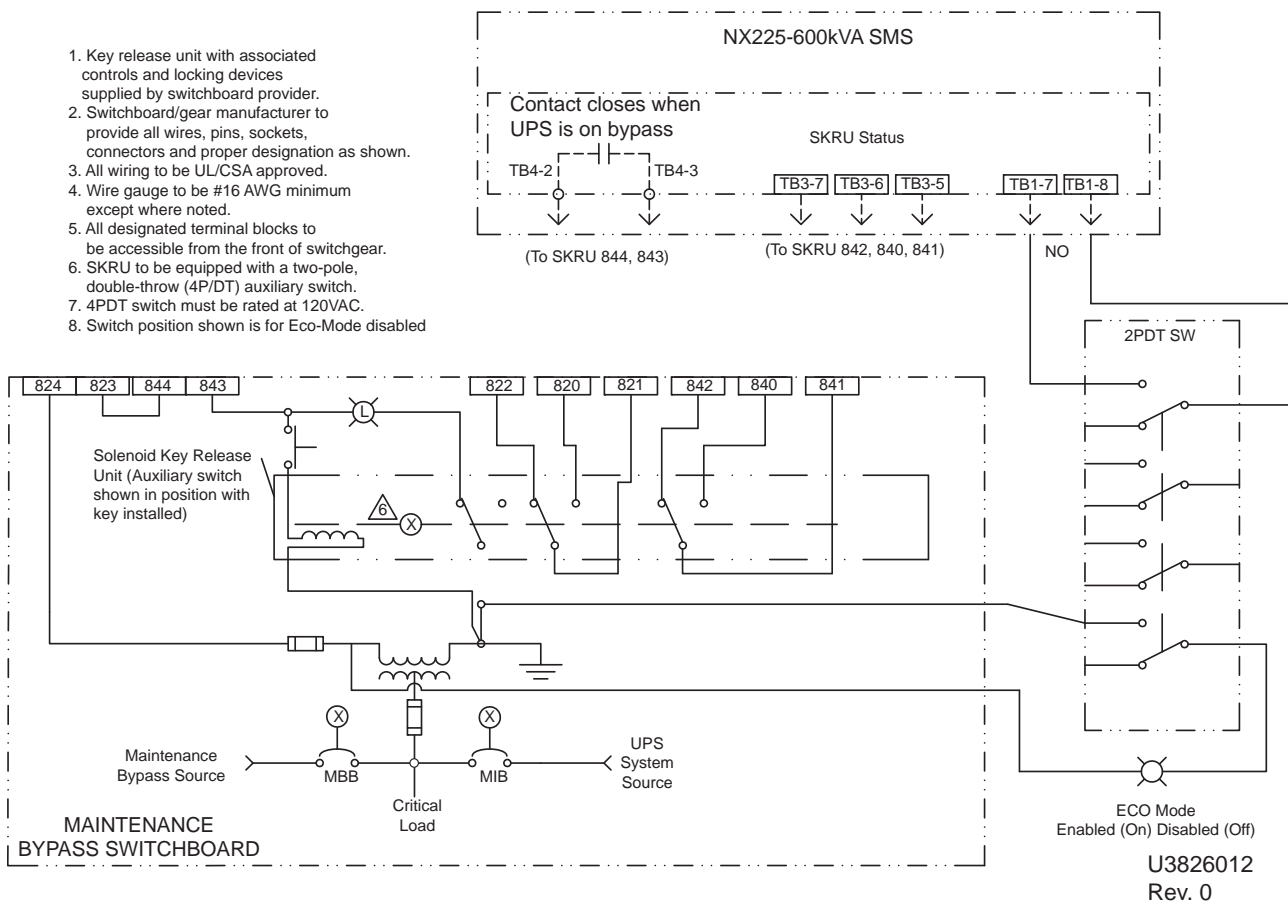


**Figure 19 Terminal details Liebert NX 400kVA - 600kVA UPS 1+N multi-module or SMS**

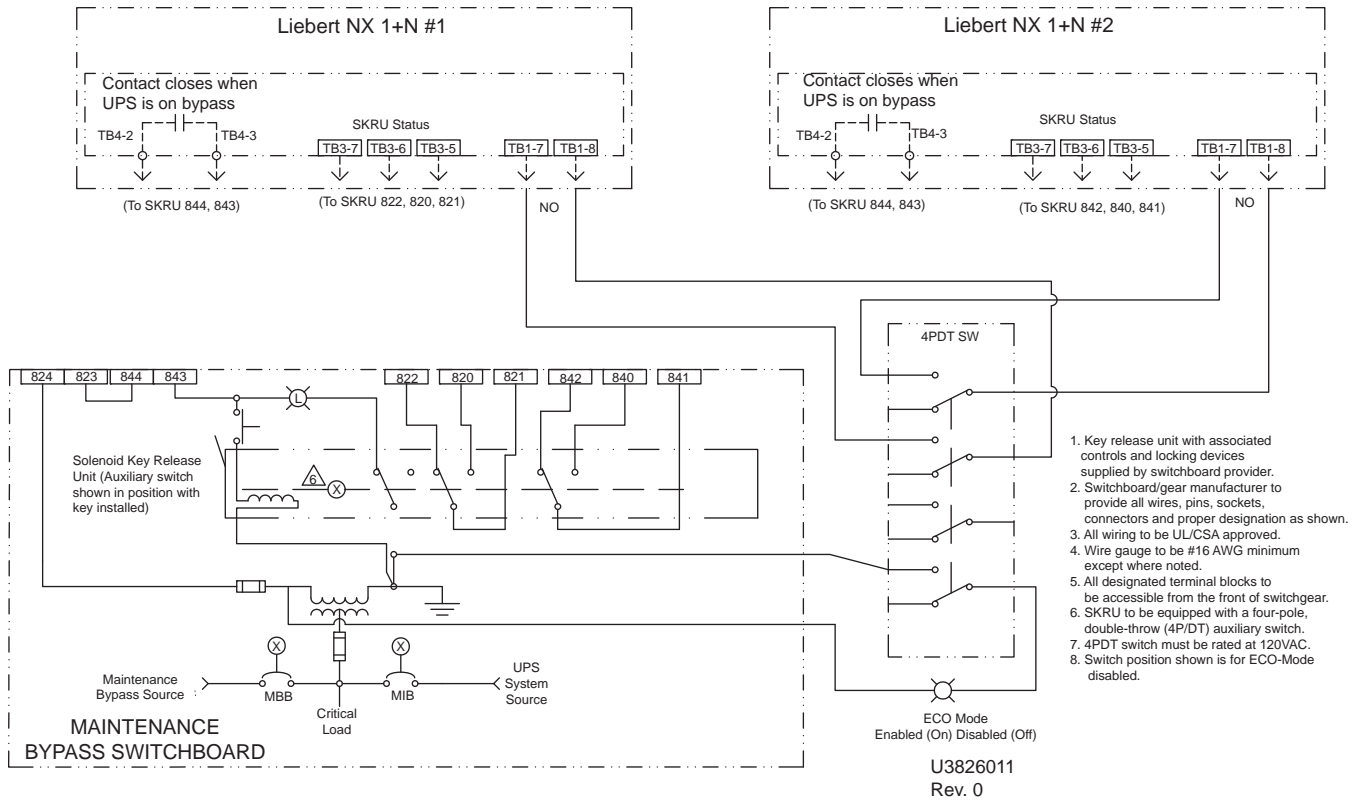


**Figure 20 Recommended control wiring for Liebert NX 225-600kVA single module, Eco Mode**

1. Key release unit with associated controls and locking devices supplied by switchboard provider.
2. Switchboard/gear manufacturer to provide all wires, pins, sockets, connectors and proper designation as shown.
3. All wiring to be UL/CSA approved.
4. Wire gauge to be #16 AWG minimum except where noted.
5. All designated terminal blocks to be accessible from the front of switchgear.
6. SKRU to be equipped with a two-pole, double-throw (4P/DT) auxiliary switch.
7. 4PDT switch must be rated at 120VAC.
8. Switch position shown is for Eco-Mode disabled



**Figure 21 Recommended control wiring for Liebert NX 225-600kVA multi-module, Eco Mode**



## 5.0 SPECIFICATIONS

Table 7 Liebert NX UPS specifications

Model Size	UPS Rating, kVA					
	225	250	300	400	500	600
<b>Input Parameters</b>						
Input Voltage to Rectifier, VAC	480V 3-phase, 3-wire					
Input Voltage to Bypass, VAC	480V 3-phase, 3-wire					
Input Voltage Range, VAC	+10% to -30% (The UPS will operate at voltages down to -12.5% of nominal at 100% load without discharging the battery. The UPS will operate without discharging the battery at 70% of full nominal load with voltage down to -30% of nominal.)					
Input Frequency, Hz	60					
Permissible Input Frequency Range, Hz	55 to 65					
Reflected Input THDi, Nominal Voltage, Full Load, %	<5%					
Power Walk-In, sec	1 to 90 (selectable) in 1 sec. Increments (Walk-in begins after a 7-second source qualification time. Special settings are available to permit shorter walk-in times for use with flywheels. Consult factory for details.)					
<b>Battery and DC Parameters</b>						
Battery Type	VRLA (Valve Regulated Lead Acid) or FLA (Flooded Lead Acid)					
Nominal Battery Bus, VDC	480V					
Battery Float Voltage, VDC	540V					
Minimum End of Discharge Voltage, VDC	396V (for VRLA / FLA)					
DC Ripple Voltage in Float & Const V Ch. Mode, %	<1 (RMS value) < 3.4% Vpp					
Temperature Compensated Battery Charging	Optional (with temperature probe)					
<b>Output Parameters</b>						
Inverter Type	IGBT-based Sine-Sine PWM Controlled					
Output Power, kW	225	250	300	400	500	600
Output Voltage, VAC	480V 3-ph, 3-wire					
Output Voltage Regulation, %	< 1% (3-phase RMS average)					
Output Voltage Regulation (100% Unb. Load)	< 2% (3-phase RMS average)					
Output Frequency, Hz	60					
Output Frequency Regulation	Synchronized to bypass: $\pm 1.2$ Hz (1.2Hz default setting, adjustable up to $\pm 3.6$ Hz by factory service personnel) Synchronized to internal clock $\pm 0.06$ Hz					
Output THDv Linear Load at Nominal Voltage, %	<2					
Output THDv at Nominal Voltage Including a 100kVA Non Linear Load per EN 62040-3, %	2.5% (max)					
Capacity to Handle High Crest Factor Load	3:1					
Unbalance Loads Current Capacity	100% of nominal phase current					
<b>Physical Parameters and Standards, in (mm)</b>						
Width, With Static Bypass	53.4 (1356)			90.7 (2304)		
Depth	33.7 (856)					
Height	78.6 (1996)					
Weight, Unpackaged, approximate, lb. (kg)	2,450 (1,110)			4,450 (2,019)		
Maximum Heat Dissipation, Full Load, BTU/hr	41,000	45,000	54,000	72,000	90,000	108,000
Color	Black (ZP-7021)					
Front Door Opening (for serviceability)	More than 90°					
Degree of Protection for UPS Enclosure	IP 20 (with and without front door open)					
Minimum Clearance, Top, in (mm)	24 (610)					

**Table 7 Liebert NX UPS specifications (continued)**

Model Size	UPS Rating, kVA					
	225	250	300	400	500	600
Minimum Clearance, Back, in (mm)	0					
Minimum Clearance, Sides, in (mm)	0					
Location of Cable Entrance	Top or Bottom					
Standards and Conformities	UL 1778, 5th Ed.					
	CSA 22.2 No. 107.3-14, 3rd Ed.					
	FCC Part 15, Class A					
	IEC62040-2, Level 4, Criteria A					
	EN61000-4-3, Level 3, Criteria A					
	EN61000-4-6, Level 4, Criteria A					
	EN61000-2-2, Criteria A					
	EN61000-4-4, Level 4, Criteria A					
	ANSI C62.41, Category A3 & B3					
	ISTA Procedure 1H					
WEEE						
<b>Environmental Parameters</b>						
Storage Temperature Range, °F (°C)	-13 to 158 (-25 to 70)					
Operating Temperature Range, °F (°C)	32 to 104 (0 to 40) (UPS)					
Relative Humidity	95% or less Non-Condensing (Operating and Non-Operating)					

**Table 8 UPS rating at altitude**

	Altitude	UPS Rating, kW					
		225	250	300	400	500	600
Rating vs. Altitude	up to 3300ft. (1000m)	225	250	300	400	500	600
	up to 4921ft. (1500m)	225	250	270	400	500	540
	up to 6562ft. (2000m)	225	250	252	400	500	504
	up to 9842ft. (3000m)	225	225	225	400	450	450

**Table 9 Current ratings—rectifier input**

UPS Rating		Voltage VAC	Nominal Current	Maximum Current
kVA	kW			
225	225	480	285	299
250	250	480	317	332
300	300	480	380	399
400	400	480	505	530
500	500	480	632	663
600	600	480	761	799

**Table 10 Current ratings—bypass**

UPS Rating kVA/kW	Voltage, VAC	Nominal Current
225	480	271
250	480	301
300	480	361
400	480	481
500	480	601
600	480	722

**Table 11 Current ratings—output**

UPS Rating kVA/kW	Voltage, VAC	Nominal Current
225	480	271
250	480	301
300	480	361
400	480	481
500	480	601
600	480	722

**Table 12 Current ratings—battery**

UPS Rating kVA/kW	Nominal VDC	Maximum Battery Current
225	480	600
250	480	667
300	480	800
400	480	1068
500	480	1335
600	480	1600

**Notes on Tables**

1. Nominal input current (considered continuous) is based on full-rated output load. Maximum current includes nominal input current and maximum battery recharge current (considered non-continuous). Continuous and non-continuous current are defined in NEC 100.
2. For breaker coordination while the module is overloaded, see the current-versus-time values on the overload curves.
3. Nominal battery voltage is shown at 2.0 volts/cell.
4. Maximum Battery current at End of Discharge level of 1.65 volts per cell.
5. External DC Circuit Overcurrent Protective Device—Caution: To reduce the risk of fire, connect only to a circuit with the maximum branch circuit overcurrent protection recommended in **Table 13** in accordance with the National Electric Code, ANSI/NFPA 70.

**Table 13 Recommended DC circuit breaker rating**

UPS Rating kVA/kW	Circuit Breaker Rating, A
225	600
250	700
300	800
400	1200
500	1600
600	1600

**Table 14 Current-versus-time curves of overload capacity**

Load, %	Overload Time, sec. (min.)				
	104°F (40°C)	95°F (35°C)	86°F (30°C)	77°F (25°C)	60°F (20°C)
101	8249.9 (137.5)	10,999.8 (183.3)	13,749.8 (229.2)	16,499.7 (275)	16,499.7 (275)
105	1650.0 (27.5)	2200.0 (36.7)	2750.0 (45.8)	3299.9 (55)	3299.9 (55)
110	825.0 (13.75)	1100.0 (18.3)	1375.0 (22.9)	1650.0 (27.5)	1650.0 (27.5)
115	550.0 (9.2)	733.3 (12.2)	916.7 (15.3)	1100.0 (18.3)	1100.0 (18.3)
120	412.5 (6.9)	550.0 (9.2)	687.5 (11.5)	825.0 (13.8)	825.0 (13.8)
125	319.4 (5.3)	425.9 (7)	532.4 (8.9)	638.9 (10.6)	638.9 (10.6)
130	222.2 (3.7)	296.3 (4.9)	370.3 (6.2)	444.4 (7.4)	444.4 (7.4)
135	152.7 (2.5)	203.6 (3.4)	254.6 (4.2)	305.5 (5)	305.5 (5)
140	100.6 (1.7)	134.2 (2.2)	167.7 (2.8)	201.3 (3.4)	201.3 (3.4)
145	36.7 (—)	48.9 (—)	61.1 (1.0)	73.3 (1.2)	73.3 (1.2)
150	27.7 (—)	37.0 (—)	46.2 (—)	55.4 (—)	55.4 (—)
155	7.3 (—)	9.7 (—)	12.1 (—)	14.6 (—)	14.6 (—)
160	7.3 (—)	9.7 (—)	12.1 (—)	14.5 (—)	14.5 (—)
165	7.3 (—)	9.7 (—)	12.1 (—)	14.5 (—)	14.5 (—)

The inverter overload is based on 104°F (40°C) ambient. At lower ambient temperatures, the overload timers automatically adjust to longer run times.

**Table 15 Recommended conduit and cable sizes**

<b>Rectifier Input</b>				
<b>UPS Rating</b>		<b>Voltage (VAC)</b>	<b>(# of conduits); size of conduits; # -size of phase cables per conduit; size of cable for ground per conduit</b>	
<b>kVA</b>	<b>kW</b>		<b>Copper Conductors</b>	<b>Aluminum Conductors</b>
225	225	480	(1) 2.5C 3-500kcmil, #4AWG	(1) 2.5C 3-700kcmil, #2AWG
250	250	480	(1) 3.0C 3-600kcmil, #3AWG	(2) 2.0C 3-300kcmil, #1AWG
300	300	480	(2) 2.0C 3-250kcmil, #3AWG	(2) 2.0C 3-350kcmil, #1AWG
400	400	480	(2) 2.5C 3-500kcmil, #1AWG	(2) 2.5C 3-600kcmil, #2/OAWG
500	500	480	(2) 3.0C 3-600kcmil, #1/OAWG	(3) 2.5C 3-500kcmil, #3/OAWG
600	600	480	(3) 2.5C 3-500kcmil, #1/OAWG	(3) 2.5C 3-600kcmil, #3/OAWG
<b>Bypass Input</b>				
<b>UPS Rating</b>		<b>Voltage (VAC)</b>	<b>(# of conduits); size of conduits; # -size of phase cables per conduit; size of cable for ground per conduit</b>	
<b>kVA</b>	<b>kW</b>		<b>Copper Conductors</b>	<b>Aluminum Conductors</b>
225	225	480	(1) 2.5C 3-500kcmil, #4AWG	(1) 2.5C 3-600kcmil, #2AWG
250	250	480	(1) 2.5C 3-500kcmil, #3AWG	(1) 3.0C 3-750kcmil, #1AWG
300	300	480	(2) 1.5C 3-#4/OAWG, #3AWG	(2) 2.0C 3-300kcmil, #1AWG
400	400	480	(2) 2.0C 3-350kcmil, #2AWG	(2) 2.5C 3-500kcmil, #1/OAWG
500	500	480	(2) 2.5C 3-500kcmil, #1/OAWG	(2) 3.0C 3-750kcmil, #3/OAWG
600	600	480	(2) 3.0C 3-750kcmil, #1/OAWG	(3) 2.5C 3-500kcmil, #3/OAWG
<b>Output</b>				
<b>UPS Rating</b>		<b>Voltage (VAC)</b>	<b>(# of conduits); size of conduits; # -size of phase cables per conduit; size of cable for ground per conduit</b>	
<b>kVA</b>	<b>kW</b>		<b>Copper Conductors</b>	<b>Aluminum Conductors</b>
225	225	480	(1) 2.5C 3-500kcmil, #4AWG	(1) 2.5C 3-600kcmil, #2AWG
250	250	480	(1) 2.5C 3-500kcmil, #3AWG	(1) 3.0C 3-750kcmil, #1AWG
300	300	480	(2) 1.5C 3-#4/OAWG, #3AWG	(2) 2.0C 3-300kcmil, #1AWG
400	400	480	(2) 2.0C 3-350kcmil, #2AWG	(2) 2.5C 3-500kcmil, #1/OAWG
500	500	480	(2) 2.5C 3-500kcmil, #1AWG	(2) 3.0C 3-750kcmil, #3/OAWG
600	600	480	(2) 3.0C 3-750kcmil, #1AWG	(3) 2.5C 3-500kcmil, #3/OAWG
<b>Battery (Copper Conductors Only for Battery)</b>				
<b>UPS Rating</b>		<b>Voltage (VAC)</b>	<b>(# of conduits); size of conduits; # -size of phase cables per conduit; size of cable for ground per conduit</b>	
<b>kVA</b>	<b>kW</b>		<b>Copper Conductors</b>	
225	225	480	(2) 2C 2-500kcmil, #1/OAWG	
250	250	480	(2) 2C 2-600kcmil, #1/OAWG	
300	300	480	(2) 2.5C, 2-600kcmil, #2/OAWG	
400	400	480	(3) 2.5C, 2-600kcmil, #3/OAWG	
500	500	480	(3) 2.5C, 2-750kcmil, #4/OAWG	
600	600	480	(5) 2.5C, 2-600kcmil; 250kcmil	

1. Recommended cable sizes are 167°F (75°C) (THW) wire at 86°F (30°C) ambient.
2. For continuous operations not at 86°F (30°C), Vertiv recommend that the site planner choose the appropriate cable type based on the particular installation requirements.
3. Recommended conduit is based on FMC type conduit.



**Table 16 Recommended lug sizes**

Cable Size	T&B Copper One Hole	T&B Copper Two Hole	T&B Aluminum One Hole	T&B Aluminum Two Hole
#8AWG	54930BE	54850BE	60104-TB	—
#6AWG	54905BE	256-30695-868	60109-TB	—
#4AWG	54906BE	256-30695-733	60114-TB	—
#2-3AWG	54942BE	54811BE	60120	—
#1AWG	54947BE	54857BE	60126	—
#1/0AWG	54950BE	256-30695-593	60132	—
#2/0AWG	54951BE	54862BE	60138	60238
#3/0AWG	54965BE	54864BE	60144	60244
#4/0AWG	54970BE	54866BE	60150	60250
250kcmil	54913BE	54868BE	60156	60256
300kcmil	54914BE	54870BE	60162	60262
350kcmil	54915BE	54872BE	60165	60267
400kcmil	54916BE	54874BE	60168	60269
500kcmil	54918BE	54876BE	60171	60273
600kcmil	54920BE	54878BE	60176	60275
750kcmil	54922BE	54880BE	60178	60277

**Table 17 Recommended torque values**

Grade 5 Steel: Unified Thread System Torque, lbf.*in.			
Fastener Finish		Plain Steel	Zinc Plating
Size	Threads/ Inch, Tpi	No Washer/ Flat Washer	No Washer/ Flat Washer
1/4	20	101	91
	28	116	104
5/16	18	209	188
	24	231	208
3/8	16	370	333
	24	420	378
7/16	14	593	534
	20	662	596
1/2	13	904	814
	20	1020	918
9/16	12	1305	1175
	18	1456	1310

Class 8.8 Steel: Metric Thread System Torque, N*m			
Fastener Finish		Plain Steel	Zinc Plating
Size	Thread Pitch, Tp	No Washer/ Flat Washer	No Washer/ Flat Washer
M5	0.8	6.1	5.5
	0.5	6.9	6.2
M6	1	10	9
	0.75	11	10
M8	1.25	25	23
	1	27	24
M10	1.5	50	45
	1.25	53	47
M12	1.75	87	78
	1.25	95	86
M14	2	139	125
	1.5	151	136

**Table 18 Components required for seismic configuration meeting OSHPD regulations**

<b>Part #</b>	<b>Description</b>
NXOSH300	OSHPD Floor Anchor NX 300 kVA UPS Module
NXOSH600	OSHPD Floor Anchor NX 600 kVA Module
NXOSHFTBC	OSHPD Floor Anchor NX Front Terminal Battery Cabinet
NXOSH TTBC	OSHPD Floor Anchor NX Top Terminal Battery Cabinet
NXOSH NJC	OSHPD Floor Anchor NX Top Terminal Battery 393mm Junction Cabinet
NXOSH PJC	OSHPD Floor Anchor NX Front Terminal Battery 393mm Junction Cabinet
NXOSH WJC	OSHPD Floor NX 785mm Junction Cabinet

## Notes

## **TECHNICAL SUPPORT / SERVICE**

### **Web Site**

[www.vertivco.com](http://www.vertivco.com)

### **Monitoring**

[liebert.monitoring@vertivco.com](mailto:liebert.monitoring@vertivco.com)

800-222-5877

Outside North America: +00800 1155 4499

### **Three-Phase UPS & Power Systems**

800-543-2378

Outside North America: 614-841-6598

## **LOCATIONS**

### **United States**

1050 Dearborn Drive

P.O. Box 29186

Columbus, OH 43229

### **Europe**

Via Leonardo Da Vinci 8

Zona Industriale Tognana

35028 Piove Di Sacco (PD) Italy

+39 049 9719 111

Fax: +39 049 5841 257

### **Asia**

29/F, The Orient Square Building

F. Ortigas Jr. Road, Ortigas Center

Pasig City 1605

Philippines

+63 2 687 6615

Fax: +63 2 730 9572

---



**©2017 Vertiv Co. All rights reserved throughout the world**

VertivCo.com | Vertiv Headquarters, 1050 Dearborn Drive, Columbus, OH, 43085, USA

Vertiv and the Vertiv logo are trademarks or registered trademarks of Vertiv Co. All other names and logos referred to are trade names, trademarks or registered trademarks of their respective owners.

While every precaution has been taken to ensure accuracy and completeness herein, Vertiv Co. assumes no responsibility, and disclaims all liability, for damages resulting from use of this information or for any errors or omissions. Specifications are subject to change without notice.

This document may contain confidential and/or proprietary information of Liebert Corporation, and its receipt or possession does not convey any right to reproduce, disclose its contents, or to manufacture or sell anything that it may describe. Reproduction, disclosure, or use without specific authorization from Liebert Corporation is strictly prohibited.