



ИБП Liebert NXL (250-800 кВА) - брошюра на продукцию. Юниджет

Постоянная ссылка на страницу: <https://www.uni-jet.com/catalog/ibp/online-ibp/liebert-chloride-nxl/>





VERTIV™

Liebert®

NXL™ UPS

250kVA - 800kVA

Maximum Protection UPS For
Medium and Large Data Centers



Achieving Maximum Protection: Delivering Continuous Power During Virtually Any Input Condition



Every business has unique needs for their data center. If your needs focus on maximum protection in terms of availability, look for a UPS designed to deliver the highest quality power at all times.

Liebert® NXL™ UPS systems from Vertiv™ utilize the latest power protection technology to create a new level of reliability and performance for data center applications.

Liebert NXL UPS systems support high power applications in medium to large data centers that are facing growing power demands. This Maximum Protection solution features:

- Handles a stack-up of multiple adverse conditions at once without compromising your connected IT load.
- Modules with input isolation transformers maintain on-line operation without transfer to bypass during DC ground fault conditions. In units with input isolation transformers (500, 625, 750 kVA), battery ground fault isolation results in normal system operation even under battery ground fault conditions – the system does not go to bypass. An alarm will direct the user to take corrective action, but operation is maintained.
- Fuse-less bypass design allows fault coordination of distribution system.

The industry leader in large UPS systems, Vertiv offers the largest and most comprehensive support network, including applications engineering, project management, a witness test facility to offer proof of performance, and the industry's largest global service network.

Liebert NXL UPS is the right choice for critical, high power applications:

- Listed and labeled to UL1778 fourth edition. The fourth edition is more harmonized with internationalized standards and requires testing for both safety and performance resulting in a more reliable UPS.
- Handles a wide window of input voltage and frequency, including power from backup generators.
- Robust design allows operation at 100% load under a “stack-up” of conditions that would require other systems to de-rate their output or compromise system availability. Simultaneous conditions such as clogged air filters, high ambient temperature, high altitude, fan failure, and low or high line conditions have been mitigated to ensure full rating at 100% operating loads.
- High inverter overload rating allows the UPS to stay on inverter delivering full regulated power, even in overload situations.
- Continuous duty rated Bypass Static Switch ensures maximum fault clearing capability in case of extreme overload or downstream short-circuits.

Liebert NXL UPS— Stack Up Performance

100% Load
Low & High Line Conditions
40°C / 104°F Temperature
50% Clogged Air Filter
Fan Failure
High Altitude 1500 Meters

Liebert NXL UPS is designed to handle all severe conditions simultaneously and still support 100% load with no need for derating.

New Technology For A New Level Of Performance

With over four decades of the most reliable UPS systems, and the industry's most experienced engineering resources, Vertiv™ has delivered the Liebert® NXL™ UPS—the latest generation of high availability, high performance UPS for critical data center equipment.

- Employs the latest generation insulated gate bipolar transistors (IGBTs) and advanced inverter logic with active harmonic control for enhanced performance under a wide range of power conditions.
- Provides high efficiency, up to 94%, but more importantly, the efficiency is optimized with a very flat efficiency curve that peaks at about 50% load where most UPS systems, especially redundant UPS systems, are operating. This results in significant savings on the energy bill.
- Digital control technology provides precise, drift-free regulation of system operation.
- Supports leading power factor loads up to 0.95 without derating, addressing the power needs of current and future generations of computers.

The Liebert NXL UPS is Ideally Suited For:

Enterprise data centers	Healthcare
Co-location	Finance
Web Hosting	Education
Government	Insurance

Any other application requiring high levels of power availability and computer-grade power quality

Flexibility:

- Matching battery and maintenance bypass cabinets for easy configuration.
- Top or bottom cable entry.
- Front access for installation and service.
- Available in single-module and multi-module configurations with both single and multi-bus distribution.
- Easy, safe access for adding or changing monitoring cards without shutdown.

Higher Availability:

- 100% rated continuous duty bypass static switch—unfused.
- Superior handling of present and future leading power factor computer loads.
- Short Circuit Withstand Rating (SCWR) withstand capability: 480V - 65kA, 100kA; 600V - 35kA, 65kA.
- Color touch screen display improve user interface and reduce risk of human error.
- Built-in galvanic isolation provides proper grounding without requiring a neutral.
- Excellent dynamic performance.
- Liebert ActiveStar® Digital Signal Processor (DSP) all digital controls.
- Multi-module configurations provide for greater total capacity and module redundancy.
- Module level redundant components—fans and power supplies.

- Generator and utility friendly with low input current distortion.
- Highest documented MTBF > 5 million hours.

Lowest Total Cost Of Ownership:

- Front access for installation and service.
- Reduced installation and service time.
- Internal bypass backfeed breaker avoids the complication of a device in the distribution switchgear that must be controlled from the UPS but trip power provided from a source energized when the bypass is deenergized.
- Up to 98% efficiency when operating in Active Inverter Eco-Mode. Up to 94% operating efficiency in dual conversion mode.
- Optimized part-load efficiencies.
- Improved cable access results in faster installation.
- Built-in battery cabinet breaker isolates string for ease of service.
- Battery cabinet with interconnecting bussing reduces site cabling.



Matching ancillary cabinets allow line-up installation with internal cabling, offering savings on installation cost and footprint.

Shown: Battery Cabinet, 250kVA UPS, Maintenance Bypass Cabinet.

More Ways To Achieve The Level Of Protection And Reliability You Need

Single-Module Configuration

Single-module systems provide a basic protection configuration. The critical bus is powered by a single UPS system with bypass capability. The Liebert® NXL™ UPS is available in 250, 300, 400, 500, 625, 750 and 800 kVA single-module models.

Multi Module Configurations

Liebert NXL UPS units can be paralleled to obtain higher total capacity or to obtain redundancy. Many facilities have added redundant UPS modules to their critical power systems, to meet the need for maximum reliability. A redundant UPS system adds fault management capability by preventing a single module or single battery failure from taking down the critical output bus. Use of redundant UPS modules also improves maintainability since one UPS module at a time can be taken off-line for service without shutting down the whole system.

Liebert NXL UPS modules can be paralleled in 1+N as well as N+1 configurations, both configurations allows paralleling of up to 6 modules.

1+N Parallel Configuration

- Paralleling of single UPS units, offers easy scalability for increased capacity or redundancy
- Each unit has its own static switch for bypass
- Provides redundant capacity without the need for a system control cabinet
- Integrated load sharing inductors

N+1 Parallel Configuration

- Paralleling of Multi Module units, without built-in static switch
- Requires System Control Cabinet with centralized static switch
- System Control Cabinet can be easily integrated into any switchgear solution
- System rated static switch with bypass breaker offers high fault clearing capability, and high availability
- Centralized monitoring allows good visibility and easy control of total system

Liebert NXL UPS Single Module System One-Line (250-800 kVA)

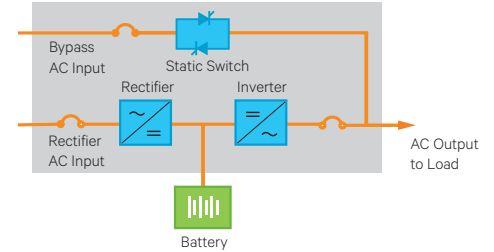

Liebert NXL UPS 1+N Multi-Module System One-Line (250-800kVA) Distributed Static Switch

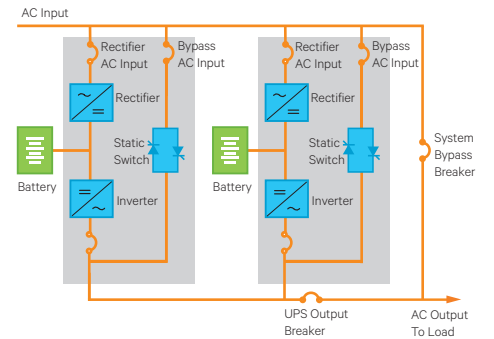

Liebert NXL UPS N+1 Multi-Module System One-Line (500 - 800 kVA) Centralized Static Switch

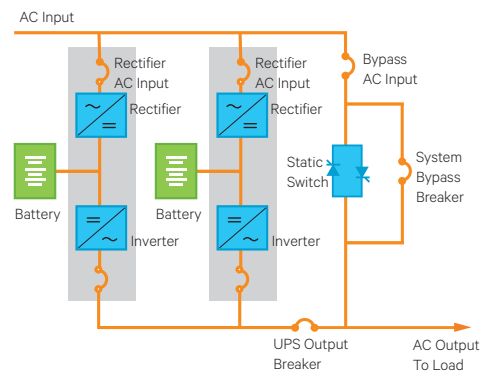

Designed For Ease Of Installation, Operation And Service

Operator Protection

NEMA1 compliant even with the first set of doors open, to allow safe and easy replacement of air filters or for the addition of Liebert IntelliSlot cards without shutting down the unit.

Serviceability

All main sub-assemblies are accessible and serviceable from the front to allow fast maintenance and service.

Liebert® NXL I/O Cabinet

Standard included Liebert SiteScan interface

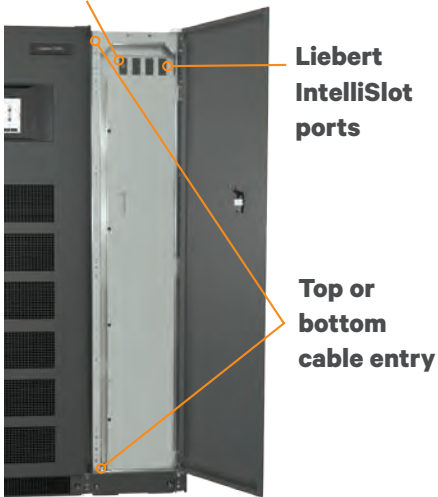

300 kVA model shown

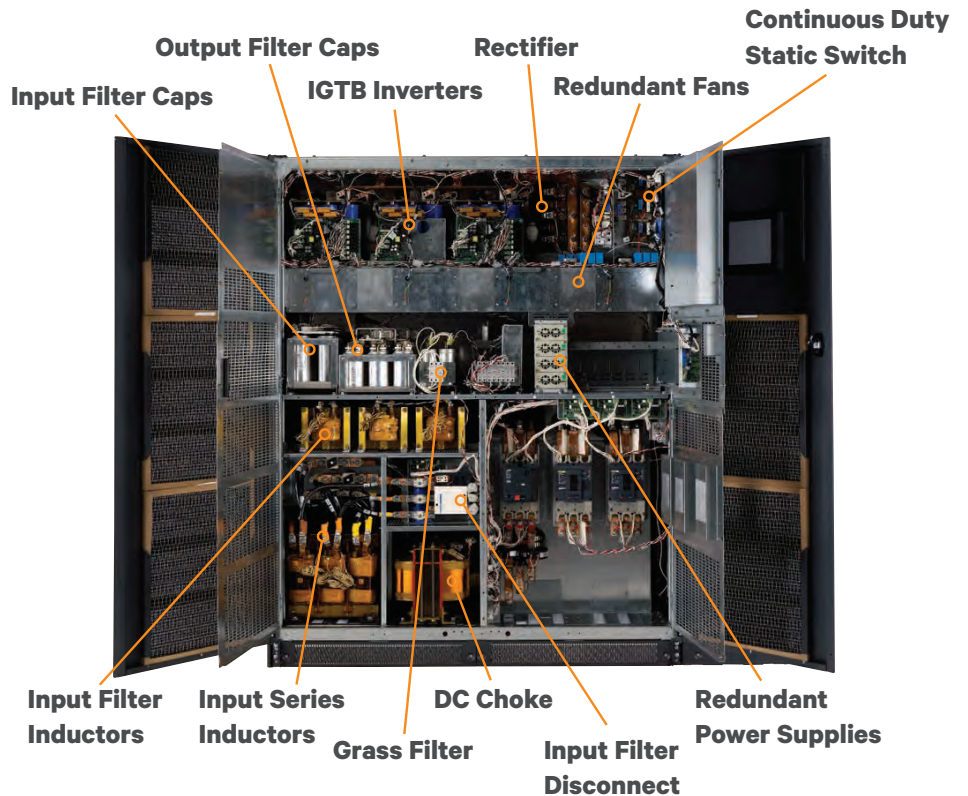
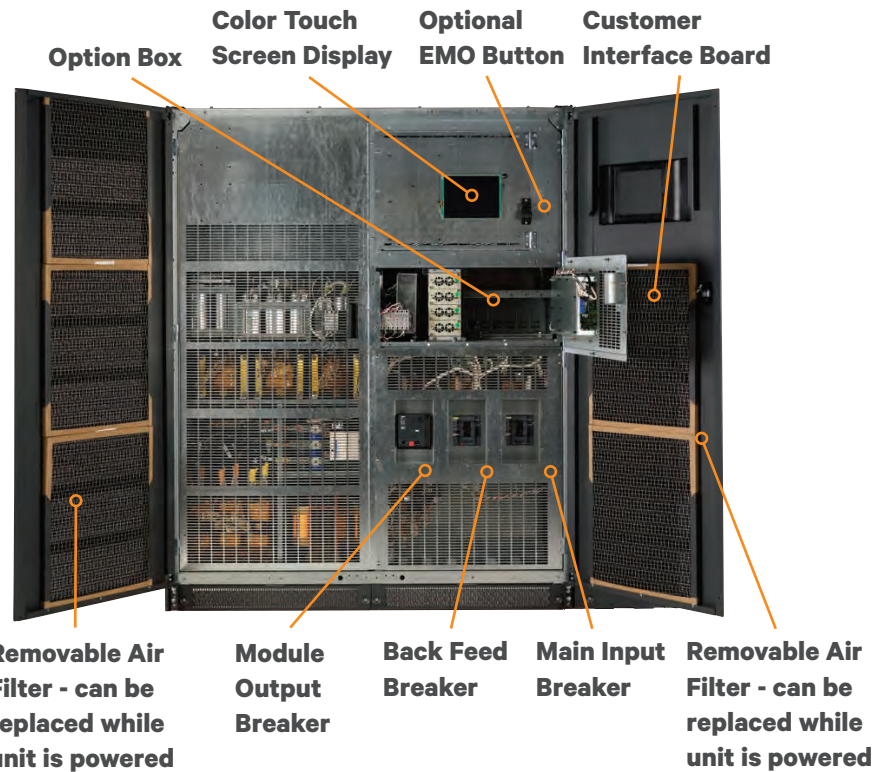

Outstanding Features Make Liebert® NXL™ UPS, The New Benchmark In Large-Scale UPS Systems

Liebert NXL UPS Standard Features:

- 6 pulse phase controlled SCR rectifier for 250-400kVA; 12 pulse for 500 - 800kVA
- Input filter with fuses
- Automatic input filter disconnect for input power factor control
- Copper galvanic isolation transformer input and output, 500-750 kVA
- Continuous duty static bypass with internal back feed breaker
- Redundant cooling fans with individual failure detection
- Two step input current limit
- Two step battery charger limit
- Automatic retransfer
- DSP controls
- Back-lit color touch screen display
- Temperature compensated battery charging/battery load test
- Top and bottom cable entry
- Latest UL 1778 Rev. 4 Listing and Labeling
- Safe and easy replacement of air filters and addition of Liebert IntelliSlot® cards without shutting down the unit.
- Internal backfeed breaker

Liebert NXL UPS

Factory Installed Options:

- Up to two programmable relay board—8 channels of status and alarm contacts on each relay board.
- Up to two input contact isolator boards—8 user programmable alarm inputs each
- Single input bus kit (250-400 kVA)
- Emergency Module Off (EMO)
- Display Keylock
- Withstand Current Rating 65kA, Standard 100kA Optional (480V)
- Load Bus Sync for multi-bus systems
- Power Tie™ for multi-bus systems

Liebert NXL UPS

Field Installed Options:

- Remote Alarm Status Panel
- External Battery Temperature Sensor
- Seismic Anchor Kits



Liebert NXL UPS (250-400 kVA)



Liebert NXL UPS (750 kVA)

System-Matched Ancillary Products Enhance System Flexibility and Availability

A comprehensive line of ancillary products provide a matched, tested and reliable power line-up, customized for your system and site needs.



Liebert® NXL™ Maintenance Bypass Cabinet (MBC)

- Allows UPS maintenance without load power down
- Attached models available
- Matched line-up design
- Top and bottom cabling
- 2 breaker configuration (250 - 500 kVA)
- Emergency Power Off (EPO)
- Optional Key Interlock System



Liebert NXL Matching Battery Cabinet

- System matched for all Liebert NXL systems
- Integral thermal measurement in each cabinet for temperature compensated charging and per cabinet thermal runaway prevention
- Optional Albér integrated battery monitoring
- Breaker for safe battery service without shutdown
- Parallelable for extended runtime or redundancy
- Internal bussing between attached cabinets to minimize site wiring



Liebert NXL System Control Cabinet

- For N+1 parallel units, the System Control Cabinet controls the operation of the system, and also contains the system Static Bypass Switch
- Integrated into the switchgear of the customers choice
- Allows control of Parallel systems with up to 6 UPS units
- Draw out design Bypass Static Switch is Continuous duty type to ensure highest availability
- Advanced color touch screen display allows easy monitoring and operation of the entire parallel system

Monitoring And Control Capabilities That Keep You Informed And In Charge

Integrated Control And Monitoring Main Display Screen

Liebert® NXL™ UPS has a large, color touchscreen display that leads the user through logical menu sequences to view needed information.

The color, backlit, micro-processor based display is autonomous of the system control logic. The simple menu-driven system virtually eliminates the possibility for human error.

The large touch screen display can be set to show a system one-line diagram or mimic panel. It can also display advanced metering information, alarms, configuration or start-up/shutdown/transfer information.

- Quickly check operational status.
- Monitor power flow through UPS along with all meter readings.
- Menu-driven operator procedures to ensure safe operation.
- Check status reports and history files.
- Adjustment of programmable parameters. Password is needed for both operations and adjustments.

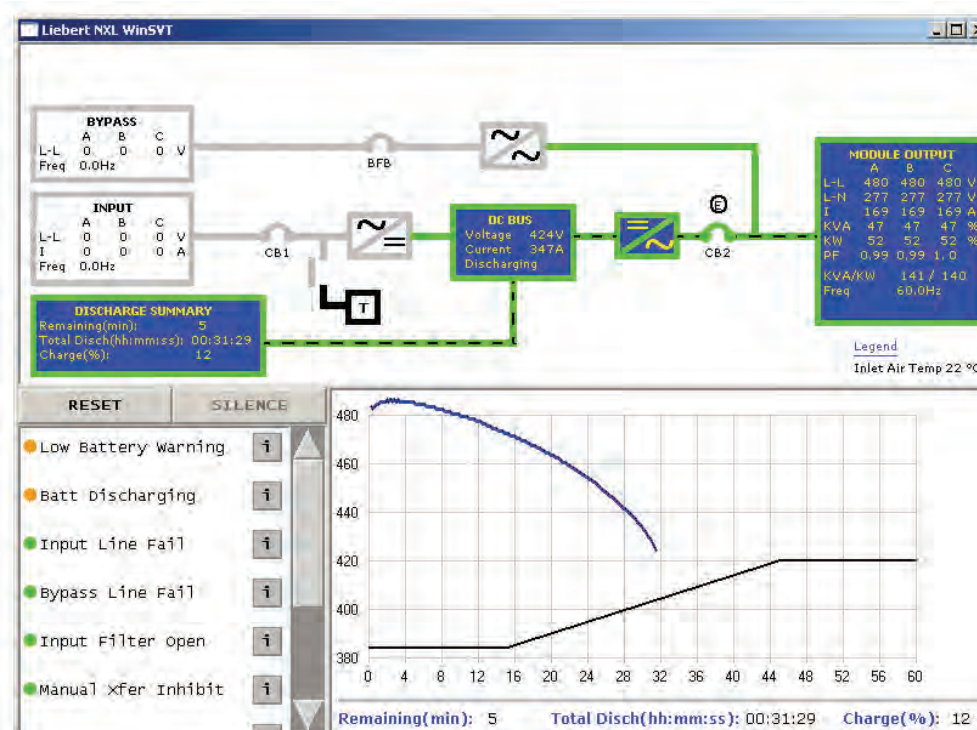

Liebert NXL UPS Display Screen

Battery Cycle Monitor

The Liebert NXL UPS system firmware collects and retains information on the last 132 events that involved discharging the UPS battery. The battery discharges are categorized by discharge duration, and crucial event details are stored, providing onscreen access to information that affects battery health. Summary information on the total number of events, cumulative ampere hours and the total discharge time since a given date is also stored and available for review. All information may also be collected remotely through the Remote Service Terminal application program.

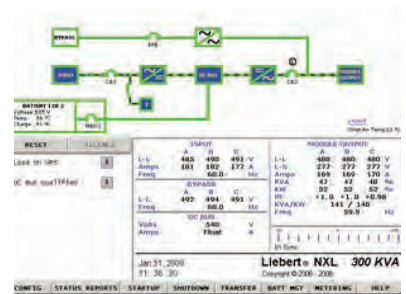

Liebert IntelliSlot™ Unity Card Communications Interface Card

The Liebert IntelliSlot Unity communications platform is the next generation of communications interface enhancing the enablement of Vertiv™ software tools and services, including *Trellis™*, Liebert Nform™, and LIFE™ Services, as well as third-party customer protocols for Vertiv equipment.

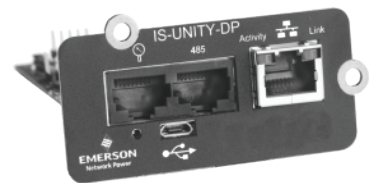

Liebert IntelliSlot Web Card

When the UPS goes into battery mode, it is vital to ensure that your batteries have enough life to run the system until the generators are available. The Liebert NXL UPS has the ability to monitor the expected run time of the batteries and provide alarms.

Battery Monitoring Options

Liebert® NXL™ UPS battery cabinets are available with factory integrated Albér battery monitoring. This factory installed and tested system continuously monitors and diagnoses battery parameters. The reporting function keeps data center personnel informed of battery health, and allows proactive battery replacement at the right time—not prematurely or after a cell failure. Battery monitoring may also be managed by Liebert Services, ensuring proper, timely maintenance by local, trained Customer Engineers.

Albér BDS-256-XL monitors and reports on the health of wet cell batteries.

Features include:

- Windows-based software for real-time viewing, automatic data collection, data analysis, and report generating.
- Remote notification to third party systems via Modbus and networks.
- Scans pertinent battery parameters every 4 seconds, including total voltage, cell voltage, current and temperature.
- Automatic proactive internal DC resistance tests.
- Discharges are automatically detected and data saved for retrieval.
- Trend analysis provides the ability to analyze performance and aid in trouble shooting.



Albér Integrated Battery Monitoring for Liebert NXL UPS Matching Battery Cabinets

Liebert SiteScan® Web Centralized Monitoring Integration

Liebert SiteScan Web centralized monitoring software offers maximum control, monitoring and visibility to Liebert NXL UPS. All Liebert monitoring software solutions are preprogrammed with the alarms and data recording features critical to system oversight. The Liebert NXL UPS also comes with the ability to output data directly to your network for integration with other monitoring systems. Multiple communication card options are available to deliver outputs and protocols required.



Liebert SiteScan Centralized Site Monitoring Provides visibility and control of All Data Center Support Equipment.



Albér BDS-256XL Monitors and Reports on the Health of Wet Cell Batteries.

The Quality And Service Difference

System Witness Testing

The Liebert® Adaptive Power Witness Test Center for large UPS systems is a state-of-the-art test facility designed to provide customers with pre-installation testing of the performance, interoperability, and efficiency of Liebert power modules and systems under a variety of conditions. Located in Delaware, Ohio, the 25,600 square-foot facility, including a 2,600 square-foot customer observation station, is the largest and most comprehensive in the industry.

Testing includes individual modules as well as the complete power system—including large UPS modules such as the Liebert NXL™ UPS and Liebert 610 system and associated support systems—and is essential to the smooth, rapid installation and commissioning of large power systems. Customers leave the Liebert Adaptive Power Witness Test Center with documented proof and confidence that their multi-module power system will seamlessly operate in accordance with business-critical availability requirements.

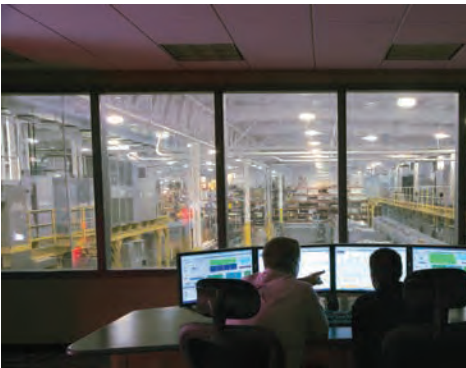

Typical UPS system verification, testing and test capabilities include but are not limited to the following:

- DC functions
- Transfer functions
- Alarms and display verification
- Parallel module tests
- Module and system Internal fault testing such as component failures or power supply failures
- Module and system loading from no load up to 150% load
- Unbalanced loading
- Battery discharge simulation
- Module and system step loading from 0 to 100%
- Short circuit tests
- Integrated tests with UPS, flywheels, switchboards, static switches, power distribution, etc
- Integrated load bus sync testing with multiple UPS systems
- Integrated Power Tie™ testing
- Integral switchgear testing
- Power quality meters
- High resistance ground
- Power monitoring
- Mimic panels
- Current and voltage harmonic analysis
- Key interlock systems
- PLC or relay based transfer controls
- Module and system level full load heat runs
- Infrared scanning
- Thermal scanning

Trust the Industry Leader for Your Service Needs

Turning to an industry leader with decades of experience, integrity and exacting standards for service delivery is the best way to ensure the availability and efficiency of your business-critical systems. The services team at Vertiv™ is factory trained and authorized to service all Liebert® power equipment, as well as provide integrated service solutions for your entire data center infrastructure.

- Hundreds of customer engineers are located throughout the United States, and each receive more than 450 hours of technical training and completes a minimum of 12 hours of safety training a year.
- Our service team has industry-leading safety ratings from the Occupational Safety and Health Administration, as well as world-class customer satisfaction and loyalty scores.
- Seven strategically located warehouses and parts hubs with \$10 million in inventory allow our service team to get the right part to the right place at the right time. Nearly 100 percent of emergency parts orders are delivered in less than 24 hours.
- Average response time to an emergency call is less than two hours, and on average, calls to 1-800-LIEBERT are resolved in less than three minutes. In fact, 70 percent of calls are resolved over the phone without the need for an on-site visit.

Protect Your Bottom Line

As organizations become increasingly dependent on IT systems to support business-critical applications, the reliability of power systems is paramount. Downtime is simply not an option, especially when the average cost of unplanned downtime is approaching \$8,000 per minute.

One of the best ways to protect your bottom line is through preventive maintenance. A Vertiv study on the relationship between preventive maintenance (PM) and UPS reliability showed that regular PM visits performed by the Original Equipment Manufacturer increased the Mean Time Between Failures (MTBF). For instance, the MTBF for a system that receives 2-4 PM visits is 23-51 times greater than a system that receives zero PM visits.

Increase in MTBF When Compared to No Preventive Maintenance

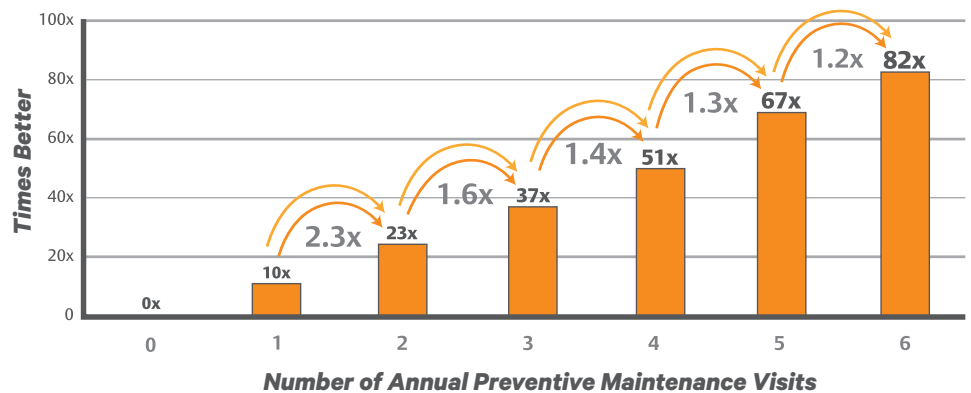

Enhance Protection with Remote Service Delivery

As part of a preventive maintenance program, remote service delivery has also proven to be instrumental in extending MTBF in addition to improving Mean Time To Repair (MTTR). By utilizing the LIFE™ technology embedded into your UPS, you can have the benefit of continuous monitoring by infrastructure specialists; data analysis by product and engineering experts; and corrective action by highly trained customer engineers and field technicians.

Preventive maintenance on your UPS and supporting infrastructure is essential for avoiding unplanned outages, but by leveraging remote diagnostics and other remote services through embedded LIFE technology, a notably higher level of service is possible.



Specifications

LIEBERT® NXL™ UPS MODEL SIZE	250 KVA	300 KVA	400 KVA	500 KVA	625 KVA	750 KVA	800 KVA
INPUT AC PARAMETERS							
Input Voltage to Rectifier	480, 575, 600 VAC 3-phase, 3-wire			480 VAC 3-phase, 3-wire	480, 575, 600 VAC 3-phase, 3-wire		480 VAC 3-phase, 3-wire
Input Voltage to Bypass	480, 575, 600 VAC 3-phase, 3- or 4-wire			480 VAC 3-phase, 3- or 4- wire	480, 575, 600 VAC 3-phase, 3- or 4-wire		480 VAC 3-phase, 3- or 4- wire
Input Voltage Range	+10%, -15% (-30% battery assist)						
Input Frequency	60 Hz						
Permissible Input Frequency Range	55 to 65 Hz						
Input THDi at nominal voltage at full load	<10%			<5%			
Power Walk-In	1 to 30 (selectable) in 1 sec. Increments						
BATTERY & DC PARAMETERS							
Battery Type	VRLA (Valve Regulated Lead Acid) or FLA (Flooded Lead Acid) or Liebert FS Flywheel						
Nominal Battery Bus	480 VDC						
Battery Float Voltage	540 VDC						
Available Recharge Power (with 100% load)	34 kW	40 kW	54 kW	67.5 kW	30 kW	100 kW	40 kW
DC Ripple Voltage in Float and Const V Ch. mode	<1 (RMS value) <3.4% Vpp						
Temperature Compensated Battery Charging	Standard (with temperature probe)						
OUTPUT PARAMETERS							
Inverter Type	IGBT PWM Control						
Output Power	250 kVA	300 kVA	400 kVA	500 kVA	625 kVA	750 kVA	800 kVA
Output Power	225 kW	270 kW	360 kW	450kW	625 kW	675 kW	800 kW
Output Voltage	480, 575, 600 VAC			480 VAC	480, 575, 600 VAC		480VAC
Output Voltage Regulation	<1% (3-phase RMS average)						
Output Voltage Regulation (50% Unb. Load)	<2% (3-phase RMS average)						
Output Frequency	60 Hz						
Output Frequency Regulation	± 0.1%						
Output THD at Nominal Voltage (Linear Load)	<2%						
Output THD at nominal voltage Including a 100kVA Non Linear Load per EN 62040-3	2.5% (max)						
Efficiency	Up to 94%			Up to 92%			Up to 94%
Transient Recovery	Within 1% of nominal voltage within 16 milliseconds for 100% step load for a single module system						
Voltage Displacement	120 deg +/- 1 deg (50% unbalanced load)						
Unbalanced loads current capacity	50% of nominal phase current						
Overload	110% for 60 minutes, 125% for 10 minutes, 150% for 1 minute, 200% for 200ms						
PHYSICAL CHARACTERISTICS							
Width, with Static Bypass	71.8 in (1,823 mm) @480VAC	78.5 in (1,993 mm)	78.5 in (1,993 mm) @480VAC	111.6 in (2,835 mm)	140.5 in (3,568 mm)		184.8 in (4,694 mm)
Width, without Static Bypass	-			111.6 in (2,835 mm)	125 in (3,175 mm)		164.8 in (4,186 mm)
Height	76.8 in (1,950 mm)						78.7 in (1,999 mm)
Weight, unpackaged, with Static Bypass	3,965 lb (1,798 kg) @480 VAC	4,690 lb (2,127 kg) @480 VAC	5,250 lb (2,381kg) @480 VAC	9,450 lb (4,286 kg)	13,200 lb (5,987 kg)		16,120 lb (7,312 kg)
Weight, unpackaged, without Static Bypass	-			9,200 lb (4,173 kg)	12,800 lb (5,806 kg)		15,010 lb (6,808 kg)
Color	Black, RAL 7021						
Protection Class, UPS Enclosure	NEMA 1, IP 20 (with and without front door open)						
STANDARDS							
Transportation	ISTA Procedure 1H						
Standards & Conformities	UL 1778 4th Edition; CSA 22.2 107.3; FCC Part 15, Class A; ANSI C62.41 B3						
WARRANTY							
Standard	1 Year						



VertivCo.com | Vertiv Headquarters, 1050 Dearborn Drive, Columbus, OH, 43085, USA

© 2016 Vertiv Co. All rights reserved. Vertiv and the Vertiv logo are trademarks or registered trademarks of Vertiv Co. All other names and logos referred to are trade names, trademarks or registered trademarks of their respective owners. While every precaution has been taken to ensure accuracy and completeness herein, Vertiv Co. assumes no responsibility, and disclaims all liability, for damages resulting from use of this information or for any errors or omissions. Specifications are subject to change without notice.

SL-30600 (R06/14)