



**uni jet**

## ИБП Liebert NXL - руководство по эксплуатации батарейной системы Юниджет

Постоянная ссылка на страницу: <https://www.uni-jet.com/catalog/ibp/on-line-ibp/liebert-chloride-nxl/>





# Liebert® Large System, 3-Phase UPS Battery System

Installation Manual

---

# BATTERY CABINET PRECAUTIONS

---

The following warning applies to all battery cabinets supplied with UPS systems. Additional warnings and cautions applicable to battery cabinets may be found in **Important Safety Instructions** beginning on **page 1**.

## **WARNING**

Internal battery strapping must be left installed or replaced prior to moving a battery cabinet (after initial installation).

- Battery cabinets contain non-spillable batteries.
- Keep units upright.
- Do not stack.
- Do not tilt.

Failure to heed this warning could result in smoke, fire or electric hazard.

Call 1-800-LIEBERT prior to moving battery cabinets (after initial installation).

---

## CONTACTING VERTIV FOR SUPPORT

---

To contact Vertiv Liebert® Services for information or repair service in the United States, call 1-800-LIEBERT (1-800-543-2378). Liebert Services offers a complete range of startup services, repair services, preventive maintenance plans and service contracts.

For repair or maintenance service outside the 48 contiguous United States, contact Liebert Services, if available in your area.

For Liebert Services to assist you promptly, have the following information available:

Part Numbers:

---

Serial Numbers:

---

Rating:

---

Date Purchased:

---

Date Installed:

---

Location:

---

Battery Voltage:

---

Battery Reserve Time:

---

## Product Warranty Registration

To register for warranty protection, visit the Service and Support section of our Web site at:

[www.liebert.com](http://www.liebert.com)

Click on Product Registration and fill out the form.

©2016 Vertiv Co. All rights reserved throughout the world.

This document may contain confidential and/or proprietary information of Liebert Corporation, and its receipt or possession does not convey any right to reproduce, disclose its contents, or to manufacture or sell anything that it may describe. Reproduction, disclosure, or use without specific authorization from Liebert Corporation is strictly prohibited.

---

---

# TABLE OF CONTENTS

<b>BATTERY CABINET PRECAUTIONS.....</b>	<b>2</b>
<b>IMPORTANT SAFETY INSTRUCTIONS.....</b>	<b>1</b>
<b>1.0 MECHANICAL INSTALLATION.....</b>	<b>3</b>
1.1 Introduction .....	3
1.2 Preliminary Checks .....	3
1.3 Environmental Considerations.....	3
1.3.1 Battery Room.....	3
1.3.2 Storage for Delayed Installation .....	3
1.4 Positioning .....	4
1.4.1 Moving the Cabinets.....	4
1.4.2 Clearances .....	6
1.4.3 Raised Floor Mounting.....	6
1.5 System Composition .....	6
<b>2.0 BATTERY INSTALLATION .....</b>	<b>7</b>
2.1 Safety.....	7
2.2 Layout.....	8
2.3 Cable Entry.....	15
2.4 Power Connection .....	15
2.4.1 Connected System.....	15
2.4.2 Connected or Stand-Alone Arrangement.....	16
2.4.3 Grounding.....	16
2.5 Control Connections .....	16
2.5.1 Liebert eXL™—UPS Control Contacts with Battery Cabinet.....	17
2.5.2 Liebert NX™—UPS Control Contacts with Battery Cabinet.....	17
2.5.3 Liebert NXL™—UPS Control Contacts with Battery Cabinet .....	19
2.6 Alber® Monitoring System—Optional .....	20
2.7 External Battery Room Temperature Sensor—Optional.....	20
<b>3.0 INSTALLATION DRAWINGS.....</b>	<b>21</b>
<b>4.0 SPECIFICATIONS.....</b>	<b>58</b>



---

## FIGURES

Figure 1	Shipping bolts—Top-terminal battery cabinet, standard width	5
Figure 2	Shipping bolts—Top-terminal battery cabinet, reduced width	5
Figure 3	Top-terminal battery system configurations—Liebert eXL™	8
Figure 4	Top-terminal battery system configurations—Liebert NX™	9
Figure 5	Top-terminal battery system configurations—Liebert NXL™	10
Figure 6	Top-terminal stand-alone battery system configuration—Liebert eXL™, Liebert NX™ and Liebert NXL™, all ratings.	11
Figure 7	Top-terminal battery system configuration—Battery cabinets not attached to UPS or each other, Liebert eXL™, Liebert NX™ and Liebert NXL™	11
Figure 8	Front-terminal battery system configurations—Liebert eXL™	12
Figure 9	Front-terminal battery system configurations—Liebert NX™	13
Figure 10	Front-terminal battery system configurations—Liebert NXL™	14
Figure 11	Front-terminal stand-alone battery system configuration—Liebert eXL™, Liebert NX™ and Liebert NXL™, all ratings.	15
Figure 12	Front-terminal battery system configuration—Battery cabinets not attached to UPS or each other, Liebert eXL™, Liebert NX™ and Liebert NXL™	15
Figure 13	Control cable layout—Liebert UPS to Liebert battery cabinet	16
Figure 14	TB3 location—225-300kVA Liebert NX™, SMS and 1+N multi-module unit with static bypass	17
Figure 15	TB3 location—400-600kVA Liebert NX™, SMS and 1+N multi-module unit with static bypass	18
Figure 16	Wiring external interface board in Liebert NXL to battery interface board in battery cabinet	19
Figure 17	Battery temperature sensor control connection	20
Figure 18	Outline drawing, Liebert top-terminal, 47" (1194mm) wide battery cabinet	21
Figure 19	Main components, Liebert top-terminal, 47" (1194mm) wide battery cabinet	22
Figure 20	Terminal details, Liebert top-terminal, 47" (1194mm) wide battery cabinet	23
Figure 21	Outline drawing, Liebert top-terminal, 55" (1400mm) wide battery cabinet.	24
Figure 22	Main components, top-terminal, 55" (1400mm) wide battery cabinet	25
Figure 23	Terminal details, top-terminal, 55" (1400mm) wide battery cabinet	26
Figure 24	Outline drawing, Liebert front-terminal battery cabinet	27
Figure 25	Main components, Liebert front-terminal battery cabinet	28
Figure 26	Terminal details, Liebert front-terminal battery cabinet	29
Figure 27	Front-terminal battery cabinet shipping split	30
Figure 28	Liebert stand-alone 32" (813mm) junction cabinet terminal wiring	31
Figure 29	Liebert attached junction cabinet—terminal details	32
Figure 30	Liebert 15-1/2" attached junction cabinet—Outline drawing	33
Figure 31	17" junction cabinet junction cabinet	34
Figure 32	Liebert battery cabinet control wiring	35
Figure 33	Attached battery cabinet connections	36
Figure 34	Ground strap location for connected cabinets	36
Figure 35	Top-terminal, standard width battery cabinet interconnection wiring to 250-400kVA UPS	37
Figure 36	Liebert top-terminal, standard width battery cabinet interconnect wiring to Liebert stand-alone junction cabinet	38
Figure 37	Terminal details Liebert NXL™ 250kVA - 400kVA to front-terminal battery point-to-point wiring.	39
Figure 38	Terminal details Liebert NXL™ 250-400kVA front-terminal battery and stand-alone junction cabinet point-to-point wiring	40

---

Figure 39	Terminal details, Liebert NXL™ 500kVA UPS to top-terminal battery and attached junction cabinet, point-to-point wiring.....	41
Figure 40	Terminal details, Liebert NXL™ 500kVA UPS to top-terminal battery and stand-alone junction cabinet, point-to-point wiring.....	42
Figure 41	Terminal details Liebert NXL™ 500kVA to top-terminal battery point-to-point wiring.....	43
Figure 42	Terminal details Liebert NXL™ 500kVA to front-terminal battery point-to-point wiring.....	44
Figure 43	Liebert NXL™ terminal details UPS 625/750kVA to front-terminal battery and attached junction cabinet point-to-point wiring.....	45
Figure 44	Liebert NXL™ terminal details UPS 625/750kVA to front-terminal battery and stand-alone junction cabinet point-to-point wiring.....	46
Figure 45	Terminal details, Liebert NXL™ 625/750kVA UPS to top-terminal battery and attached junction cabinet, point-to-point wiring.....	47
Figure 46	Terminal details, Liebert NXL™ 625/750kVA UPS to top-terminal battery and stand-alone junction cabinet, point-to-point wiring.....	48
Figure 47	Terminal details Liebert NXL™ UPS 625/750kVA to top-terminal battery point-to-point wiring.....	49
Figure 48	Terminal details 625/750kVA UPS to front-terminal battery and attached junction cabinet point-to-point wiring.....	50
Figure 49	Terminal details 625/750kVA to front-terminal battery and stand-alone junction cabinet point-to-point wiring.....	51
Figure 50	Typical Alber® battery monitoring connections.....	52
Figure 51	Alber® battery monitoring wiring to multiple battery cabinets.....	53
Figure 52	Alber® battery monitoring assembly diagram.....	54
Figure 53	Top-terminal battery configuration.....	55
Figure 54	Front-terminal battery configuration.....	56
Figure 55	Busbar connection between battery cabinet and attached junction cabinet.....	57

---

## TABLES

Table 1	Liebert eXL UPS control contacts to battery interface boards.....	17
Table 2	Liebert NX UPS control contacts to battery interface boards.....	17
Table 3	Top-terminal battery cabinet interconnection wiring to 250-400kVA UPS.....	37
Table 4	Liebert top-terminal, standard width battery cabinet interconnect wiring to Liebert junction cabinet.....	38
Table 5	Terminal details Liebert UPS 250kVA - 400kVA to front-terminal battery point-to-point interconnect wiring.....	39
Table 6	Terminal details Liebert NXL 250-400kVA front-terminal battery and stand-alone junction cabinet point-to-point interconnect wiring.....	40
Table 7	Terminal details, Liebert NXL 500kVA UPS to top-terminal battery and attached junction cabinet, point-to-point interconnect wiring.....	41
Table 8	Terminal details, Liebert NXL 500kVA UPS to top-terminal battery and stand-alone junction cabinet, point-to-point interconnect wiring.....	42
Table 9	Terminal details Liebert NXL 500kVA to top-terminal battery point-to-point interconnect wiring.....	43
Table 10	Terminal details Liebert NXL 500kVA to front-terminal battery point-to-point interconnect wiring.....	44
Table 11	Liebert NXL terminal details UPS 625/750kVA to front-terminal battery and attached junction cabinet point-to-point Interconnect wiring.....	45
Table 12	Liebert NXL terminal details UPS 625/750kVA to front-terminal battery and stand-alone junction cabinet point-to-point interconnect wiring.....	46
Table 13	Terminal details, Liebert NXL 625/750kVA UPS to top-terminal battery and attached junction cabinet, point-to-point wiring.....	47
Table 14	Terminal details, Liebert NXL 625/750kVA UPS to top-terminal battery and stand-alone junction cabinet, point-to-point interconnect wiring.....	48
Table 15	Terminal details Liebert NXL UPS 625/750kVA to battery point-to-point interconnect wiring.....	49
Table 16	Terminal details 625/750kVA UPS to front-terminal battery and attached junction cabinet point-to-point interconnect wiring.....	50
Table 17	Terminal details 625/750kVA to front-terminal battery and stand-alone junction cabinet point-to-point interconnect wiring.....	51
Table 18	Alber battery monitoring assembly connections.....	54
Table 19	Liebert NXL™ battery cabinet specifications.....	58
Table 20	Liebert NXL™ Junction Cabinet specifications.....	59
Table 21	Alber® battery monitoring option specifications.....	59
Table 22	Battery cabinet weights and breaker frame size.....	60
Table 23	Torque specifications, unless otherwise labeled.....	61
Table 24	Recommended lug sizes.....	61

# IMPORTANT SAFETY INSTRUCTIONS

## SAVE THESE INSTRUCTIONS

This manual contains important instructions that should be followed during installation of your Liebert large system three-phase UPS battery cabinet and accessories. Read this manual thoroughly, paying special attention to the sections that apply to your installation, before working with the battery system. Retain this manual for use by installing personnel.

### **WARNING**

Risk of electrical shock. Can cause personal injury and death.

Special safety precautions are required for procedures involving handling, installation and maintenance of the UPS system. Only properly trained and qualified personnel wearing appropriate personal protective equipment should be involved in installing the Liebert battery system or preparing the system for installation.

Special care must be taken when working with the batteries associated with this equipment. When connected together, the battery terminal voltage will exceed 400VDC and is potentially lethal. Be constantly aware that the battery system contains high DC as well as AC voltages. Check for voltage with AC and DC voltmeters before making contact.

Observe all DC safety precautions before working on or near the DC system.

Follow all battery safety precautions when installing, charging or servicing batteries. In addition to the hazard of electric shock, gas produced by batteries can be explosive and sulfuric acid can cause severe burns.

The following precautions must be observed when working on batteries:

- Remove watches, rings and other metal objects.
- Use tools with insulated handles.
- Wear rubber gloves and boots.
- Do not lay tools or metal parts on top of batteries.
- Disconnect charging source prior to connecting or disconnecting battery terminals.
- Determine whether the battery is grounded. If it is grounded, remove source of ground. Contact with any part of a grounded battery can result in electrical shock. The likelihood of such shock will be reduced if such grounds are removed during installation and maintenance.

If a battery leaks electrolyte, or is otherwise physically damaged, it must be replaced, stored in a container resistant to sulfuric acid and disposed of in accordance with local regulations.

If electrolyte comes into contact with skin, the affected area should be washed immediately with water.

### **WARNING**

Risk of electric shock, explosive reaction, hazardous chemicals and fire. Can cause equipment damage, personal injury and death.

Lead-acid batteries contain hazardous materials. Batteries must be handled, transported and recycled or discarded in accordance with federal, state and local regulations. Because lead is a toxic substance, lead-acid batteries must be recycled rather than discarded.

Do not dispose of a battery in a fire. The battery may explode.

Do not open or mutilate the battery or batteries. Released electrolyte is harmful to the skin and eyes. It is toxic.


### **WARNING**

Risk of electric shock. Can cause personal injury and death.

In case of fire involving electrical equipment, use only carbon dioxide fire extinguishers or those approved for use in fighting electrical fires.

## **WARNING**

Risk of heavy unit falling over. Can cause equipment damage, injury and death.  
Exercise extreme care when handling battery cabinets to avoid equipment damage or injury to personnel.  
The battery system cabinets weigh from 3155 to 9100 lb. (1431 to 4128kg).

Locate center of gravity symbols  and determine unit weight before handling each cabinet. Test lift and balance the cabinets before transporting. Maintain minimum tilt from vertical at all times.

Slots at the base of the cabinets are intended for forklift use. Base slots will support the unit only if the forks are completely beneath the unit.

## **WARNING**

Risk of electric shock. Can cause equipment damage, personal injury and death.

The area around the battery system must be kept free of puddles of water, excess moisture and debris. Observe all precautions in the relevant operation and maintenance manual before as well as during all installation and maintenance procedures. Observe all battery safety precautions before working on or near the battery.

This equipment contains several circuits that are energized with high voltage. Only test equipment designed for troubleshooting should be used. This is particularly true for oscilloscopes. Always check with an AC and DC voltmeter to ensure safety before making contact or using tools. Even when the power is turned Off, dangerously high potential electric charges may exist at the capacitor banks and at the batteries.

All power and control wiring must be installed by a properly trained and qualified electrician. All power and control wiring must comply with the NEC and applicable local codes.

When performing maintenance with any part of the equipment under power, service personnel and test equipment must be standing on rubber mats. The service personnel must wear insulating shoes for isolation from direct contact with the floor (earth ground).

One person should never work alone, even if all power is disconnected from the equipment. A second person should be standing by to assist and to summon help in case of an accident.



### **NOTE**

*Materials sold hereunder cannot be used in the patient vicinity (e.g., use where UL, cUL or IEC 60601-1 is required). Medical applications such as invasive procedures and electrical life support equipment are subject to additional terms and conditions.*

### **NOTICE**

This unit complies with the limits for a Class A digital device, pursuant to Part 15 Subpart J of the FCC rules. These limits provide reasonable protection against harmful interference in a commercial environment. This unit generates, uses and radiates radio frequency energy and, if not installed and used in accordance with this instruction manual, may cause harmful interference to radio communications. Operation of this unit in a residential area may cause harmful interference that the user must correct at his own expense.

# 1.0 MECHANICAL INSTALLATION

## 1.1 INTRODUCTION

This following section describes the requirements that must be taken into account when planning the positioning and cabling of the Liebert battery equipment.

This chapter is a guide to general procedures and practices that should be observed by the installing engineer. The particular conditions of each site will determine the applicability of such procedures.

### NOTICE

Risk of improper startup. Can cause voiding of warranty and equipment damage.

Do not apply electrical power to the UPS equipment before the arrival of the commissioning engineer.

## 1.2 PRELIMINARY CHECKS

Before installing the battery equipment, perform the following preliminary checks:

- Visually examine the equipment for transit damage, both internally and externally. Report any damage to the shipper immediately.
- Verify that the correct equipment is being installed. The equipment supplied has an identification tag inside the main door.
- Verify that the battery room satisfies the environmental conditions stipulated in the equipment specification, paying particular attention to the ambient temperature and air exchange system.

## 1.3 ENVIRONMENTAL CONSIDERATIONS

### 1.3.1 Battery Room

Batteries should be installed in an environment where the temperature is consistent and even over the whole battery. Temperature is a major factor in determining the battery life and capacity. Typical battery manufacturer performance data are quoted for an operating temperature between 68 and 77°F (20 and 25°C). Operating above this range will reduce the battery life while operation below this range will reduce the battery capacity.

#### Battery Temperature

In a normal installation, the battery temperature should be kept between 59 and 77°F (15°C and 25°C).



### NOTE

*Battery cabinets are convection-cooled. Keep batteries away from main heat sources, main air inlets and similar heating, ventilation and cooling features. These can cause inconsistent temperatures in sections of the batteries and reduce either battery life or capacity.*

### 1.3.2 Storage for Delayed Installation

If the equipment will not be installed immediately, it must be stored indoors in a clean, dry and cool location (see **Environmental Parameters** in **Table 19**). If the UPS includes batteries, either internally or in a battery cabinet, the batteries' requirements will dictate the storage conditions. Batteries should be unpacked, installed and charged as soon as possible after delivery.

### NOTICE

Risk of failure to properly charge batteries. Can cause permanent damage to batteries and void the warranty.

Batteries will self-discharge during storage. Batteries must be recharged as recommended by the battery manufacturer.

A notice of "Charge Before Date" is affixed to each unit that has batteries inside. The "Charge Before Date" is calculated based on the batteries being stored at 77°F (25°C). Storage at a higher temperature will increase the rate of self-discharge, requiring earlier recharge. Consult the battery manufacturer on how to determine when the batteries need to be recharged.

## 1.4 POSITIONING

The cabinet is structurally designed to handle lifting from the base.

Power terminals, auxiliary terminals blocks and power switches are accessed from the front and top.

Removable panels on the top are secured to the chassis by screws. The door can be opened to give access to the power connections bars, auxiliary terminal blocks and power isolators. The front door can be opened 180° for easier service and more flexibility in installation.

### 1.4.1 Moving the Cabinets

The route to be traveled between the point of arrival and the unit's installation location must be planned to make sure that all passages are wide enough for the unit and that floors are capable of supporting its weight (for instance, check that doorways, lifts, ramps, etc., are adequate and that there are no impassable corners or changes in the level of corridors).

Ensure that the cabinet weight is within the designated surface weight loading (kg/cm<sup>2</sup>) of any handling equipment. See **Tables 19** and **22** for weight details.

Ensure that any lifting equipment used to move the battery equipment has sufficient lifting capacity.

Battery system equipment can be handled by a forklift or similar equipment.

Because the weight distribution in the cabinet is not symmetrical, use extreme care during handling and transporting.


When moving the unit by forklift, care must be taken to protect the panels. Do not exceed a 15° tilt with the forklift. Bottom structure will support the unit only if the forks are completely beneath the unit.

Handling the unit with straps is not authorized.

### **WARNING**

Risk of heavy unit falling over. Can cause equipment damage, injury and death.

Exercise extreme care when handling battery cabinets. The battery system cabinets weigh from 3155 to 9100 lb. (1431 to 4128kg).

Locate center of gravity symbols  and determine unit weight before handling each cabinet. Test lift and balance the cabinets before transporting. Maintain minimum tilt from vertical at all times.

Slots at the base of the cabinets are intended for forklift use. Base slots will support the unit only if the forks are completely beneath the unit.

The cabinet with top-terminal and front-terminal batteries ships with extra bolts installed on the interior doors. Once the cabinet is in the final position, these bolts can be removed. See **Figures 1** and **2**.





### **1.4.2 Clearances**

The Liebert battery system has no ventilation grilles at either side or at the rear of the battery system equipment. It is important to leave a distance of 24" (610mm) between the top of the cabinet and the ceiling of the room where it is installed to permit adequate circulation of air coming out of the unit and for service access.

Clearance around the front of the equipment should be sufficient to enable free passage of personnel with the doors fully opened.

### **1.4.3 Raised Floor Mounting**

If the equipment is to be placed on a raised floor, it should be mounted on a pedestal suitably designed to accept the equipment point loading. Refer to the base view to design this pedestal.

## **1.5 SYSTEM COMPOSITION**

A battery system can consist of a number of equipment cabinets, depending on the individual system design requirements, e.g., Battery Cabinet, Junction Cabinet. Refer to **3.0 - Installation Drawings** for the positioning of the cabinets described below.

## 2.0 BATTERY INSTALLATION

### 2.1 SAFETY

Special care should be taken when working with the batteries associated with the Liebert battery system equipment. When all the cells are connected together, the battery terminal voltage will exceed 400V and is potentially lethal. A primary safety consideration is to install the battery equipment in an isolated area, accessible only to properly trained and qualified maintenance personnel.

#### **WARNING**

Risk of electric shock. Can cause equipment damage, personal injury and death.

Hazardous battery voltage present behind covers. No user-serviceable parts are located behind covers that require a tool for removal. Only properly trained and qualified service personnel are authorized to remove such covers or perform installation or maintenance.

The following general battery safety precautions and warnings must be observed at all times:

- A battery can present risk of electric shock or burn from high short circuit currents.
- When connected in a string, the voltage will exceed 400VDC. This voltage is potentially lethal. Always observe high-voltage precautions.
- Eye protection must be worn to prevent injury from accidental electrical arcs.
- Remove rings, watches, necklaces, bracelets and all other metal objects.
- Use only tools with insulated handles.
- Wear appropriate personal protective equipment when handling batteries.
- If a battery leaks electrolyte or is otherwise physically damaged, it should be placed in a container resistant to wire and disposed of in accordance with local regulations.
- If electrolyte comes into contact with skin, the affected area should be washed immediately with plenty of clean water.
- Batteries must always be disposed of according to local environmental laws.
- When replacing batteries, use the same number and type that were originally fitted.
- Disconnect charging source prior to connecting or disconnecting battery terminals.
- Determine if the battery is grounded. If it is grounded, remove source of ground. Contact with any part of a grounded battery can result in electrical shock.
- Battery support tray must be used whenever a battery tray is being pulled out.

## 2.2 LAYOUT

Depending on the site layout, the battery cabinets can be installed in any of several ways:

- Connected to Module—One or more battery cabinets bolted to the UPS
- Stand-Alone Individual Cabinets—Single battery cabinets not bolted to the UPS
- Stand-Alone Interconnected Cabinets—Multiple battery cabinets not bolted to the UPS

See **Figures 3** through **7** for top terminal battery cabinets.

See **Figures 8** through **12** for front terminal battery cabinets.

**Figure 3 Top-terminal battery system configurations—Liebert eXL™**

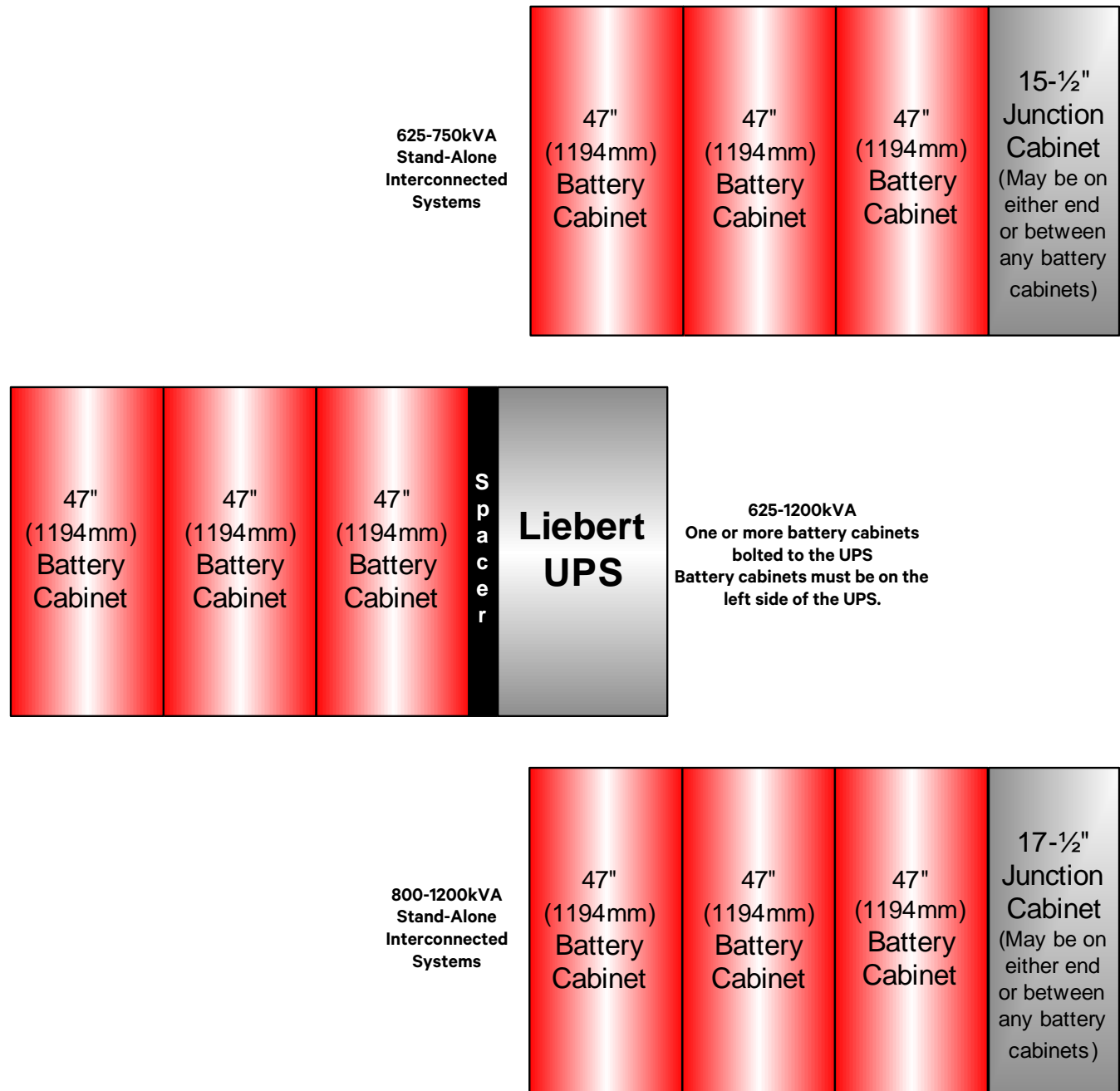
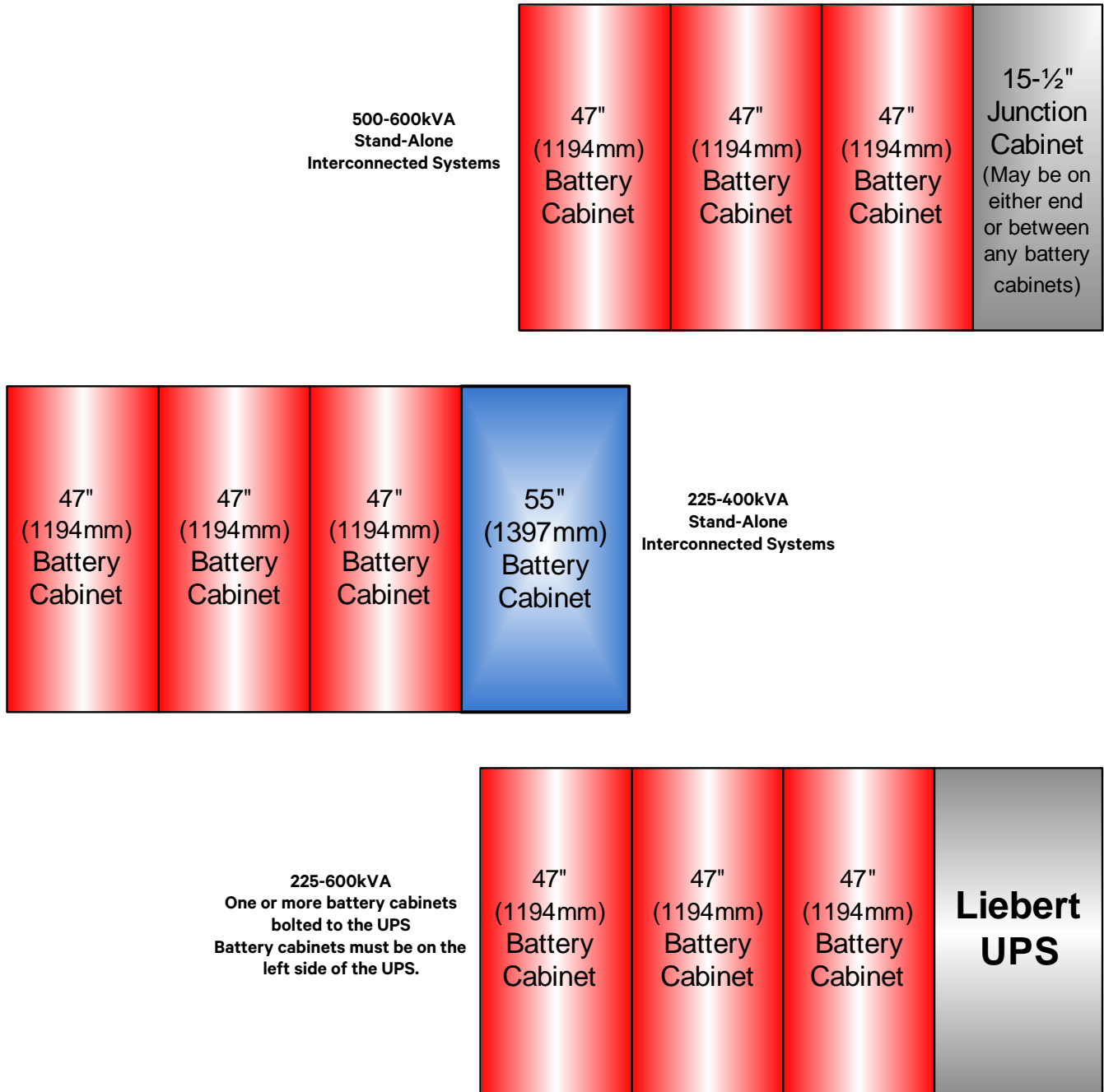
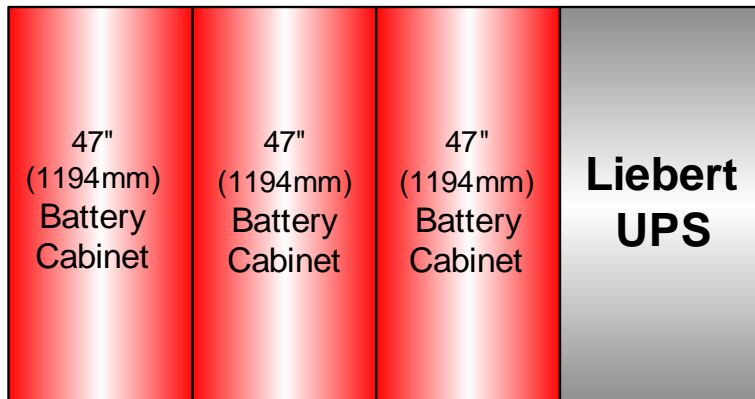
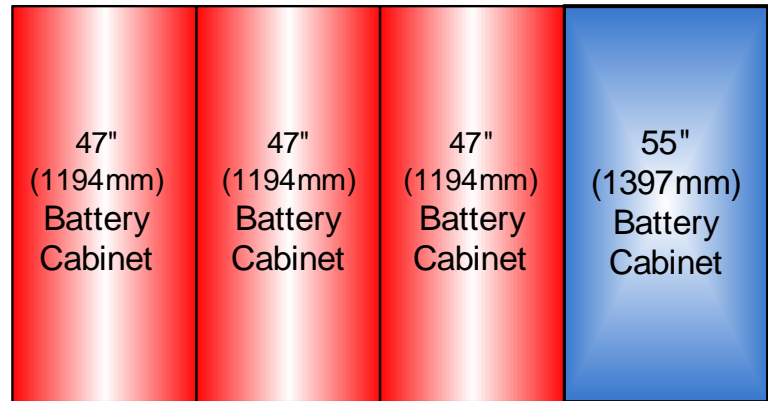


Figure 4 Top-terminal battery system configurations—Liebert NX™



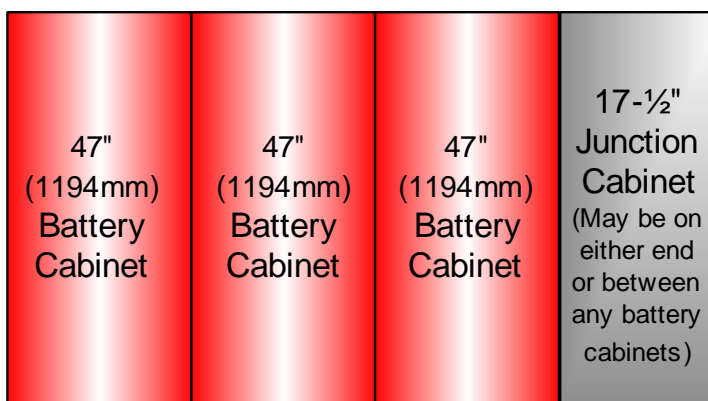
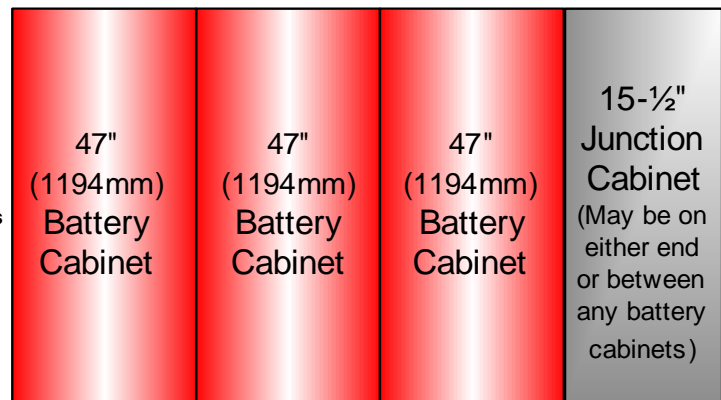
**Figure 5 Top-terminal battery system configurations—Liebert NXL™**

**250-400kVA  
Stand-Alone  
Interconnected Systems**  
55" battery cabinet must be  
on the right side of the 47"  
(1194mm) cabinets.



**250-750kVA**  
One or more battery cabinets bolted to the UPS  
Battery cabinets may be on either side of a  
250-300kVA UPS and 400kVA 480V UPS.  
Battery cabinets must be on the left side of a  
500-750kVA UPS.  
Battery cabinets must be on the left side of a  
400kVA 575/600V UPS.

**500-750kVA  
Stand-Alone  
Interconnected Systems**



**800-1100kVA  
Stand-Alone  
Connected Systems**

Figure 6 Top-terminal stand-alone battery system configuration—Liebert eXL™, Liebert NX™ and Liebert NXL™, all ratings

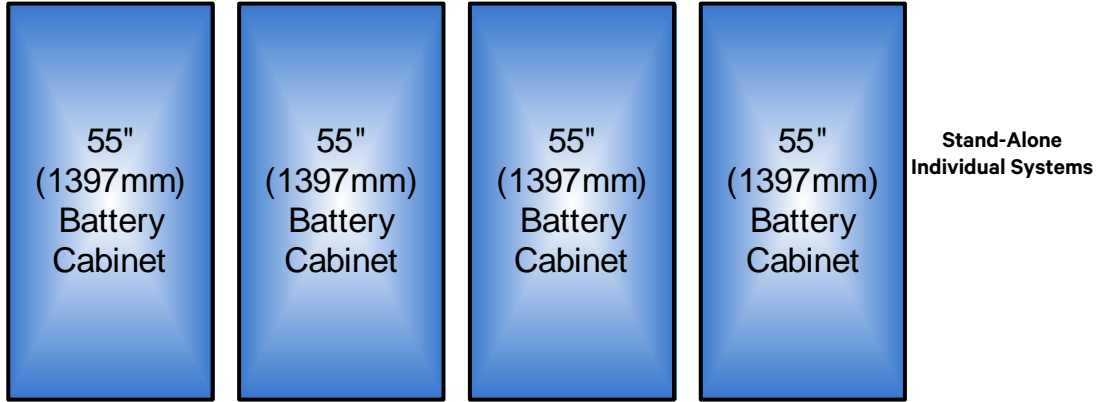
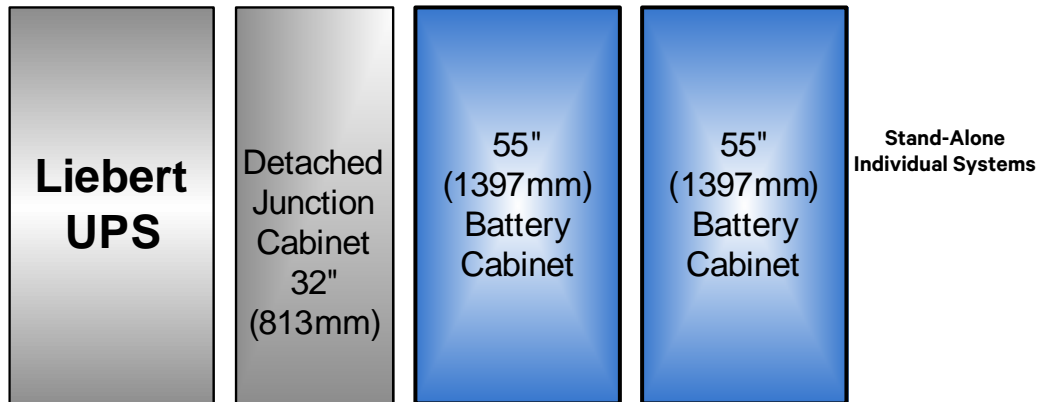


Figure 7 Top-terminal battery system configuration—Battery cabinets not attached to UPS or each other, Liebert eXL™, Liebert NX™ and Liebert NXL™



**Figure 8** Front-terminal battery system configurations—Liebert eXL™

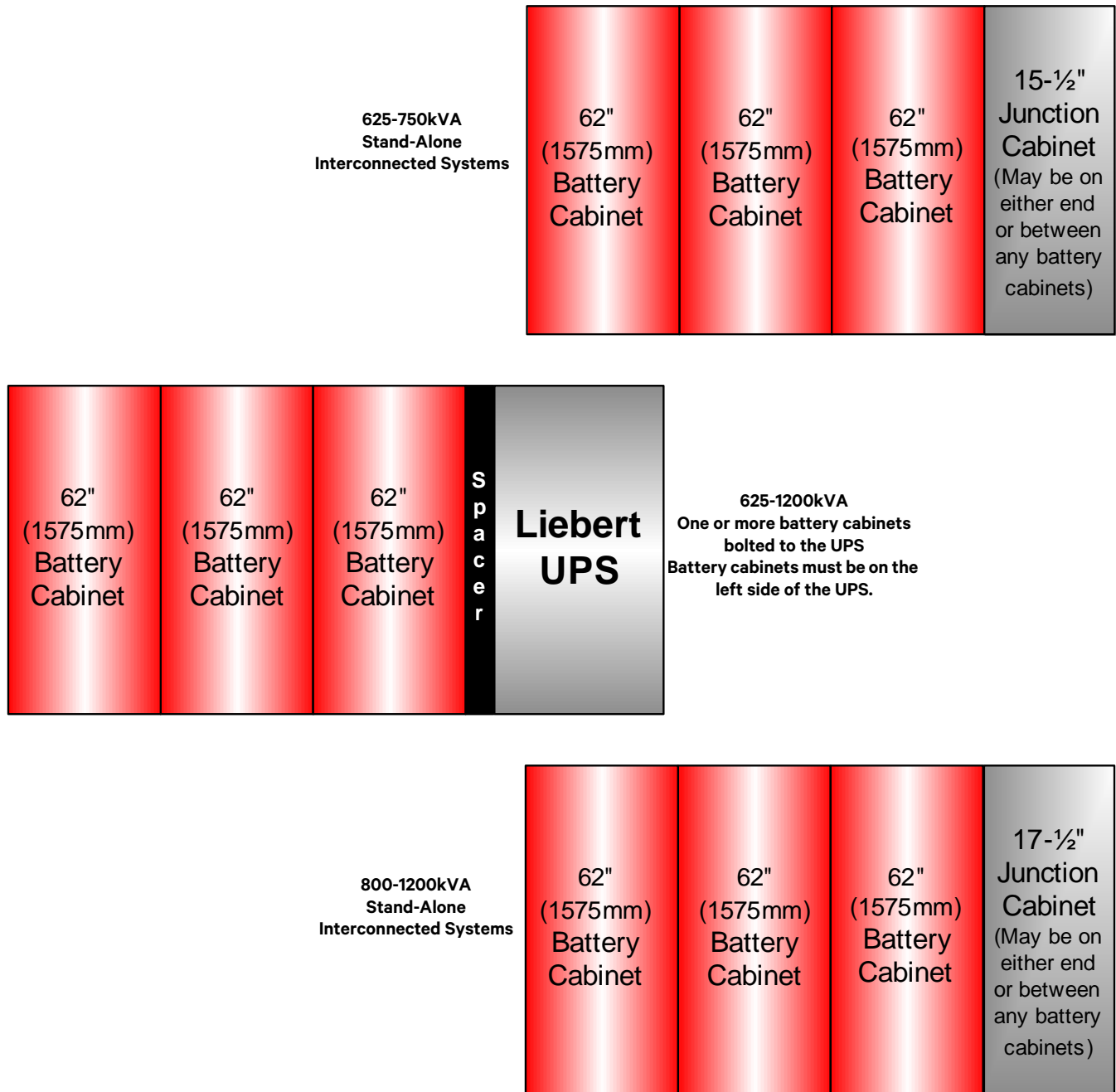
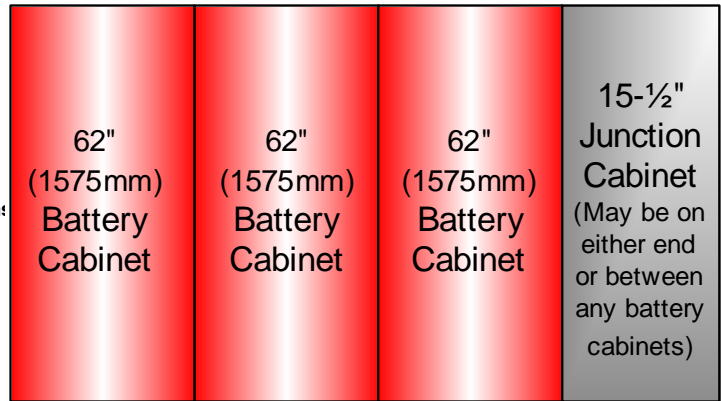
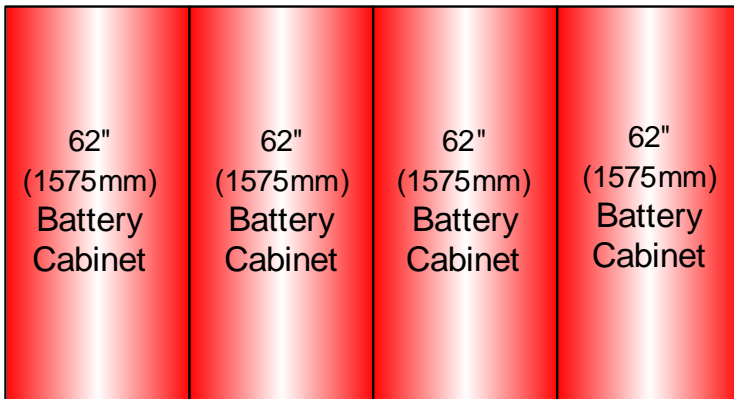


Figure 9 Front-terminal battery system configurations—Liebert NX™

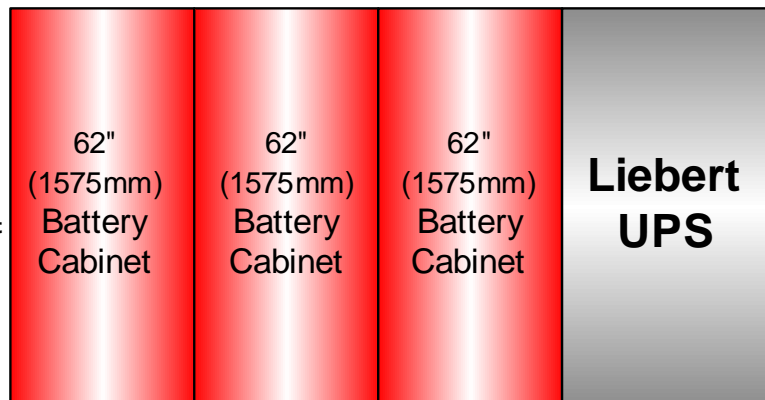
500-600kVA  
Stand-Alone  
Interconnected System:



225-400kVA  
Stand-Alone  
Interconnected Systems



225-600kVA  
One or more battery cabinets  
bolted to the UPS  
Battery cabinets must be on left  
side of UPS.





**Figure 10** Front-terminal battery system configurations—Liebert NXL™

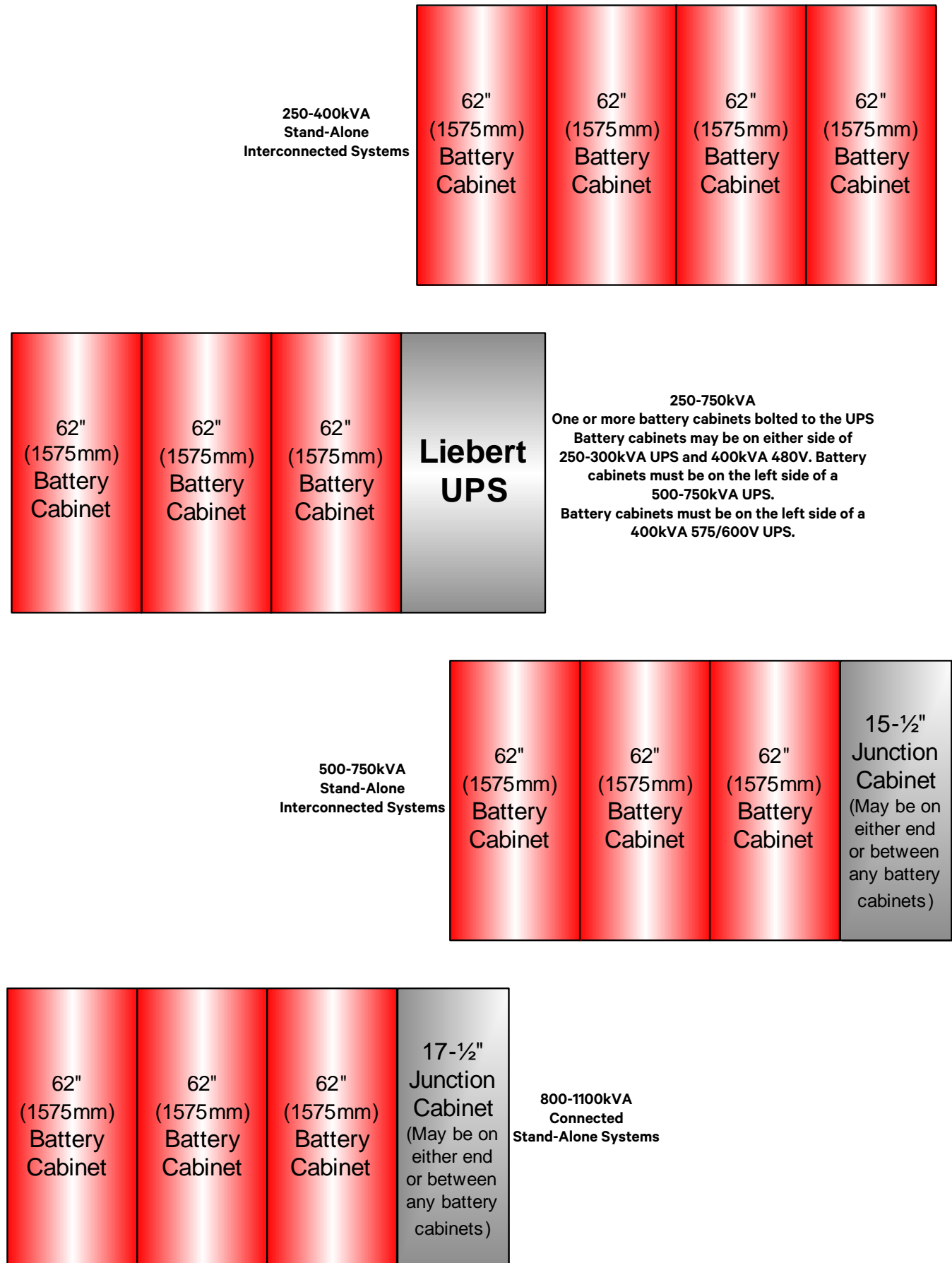


Figure 11 Front-terminal stand-alone battery system configuration—Liebert eXL™, Liebert NX™ and Liebert NXL™, all ratings

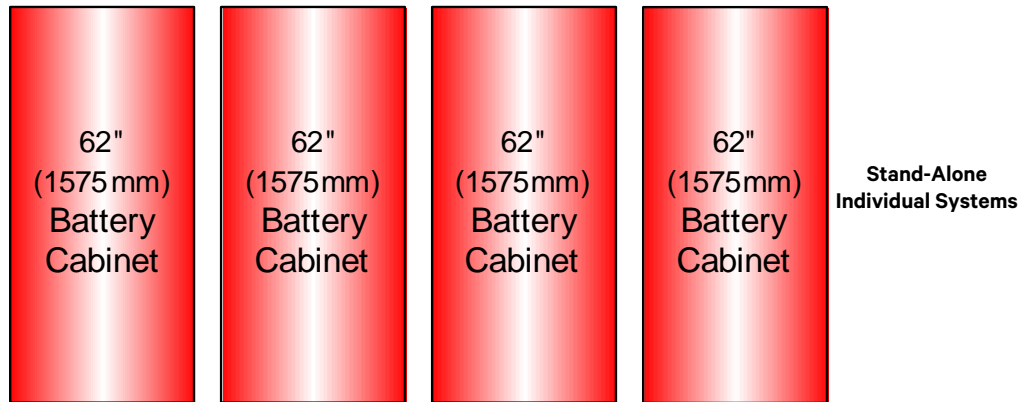
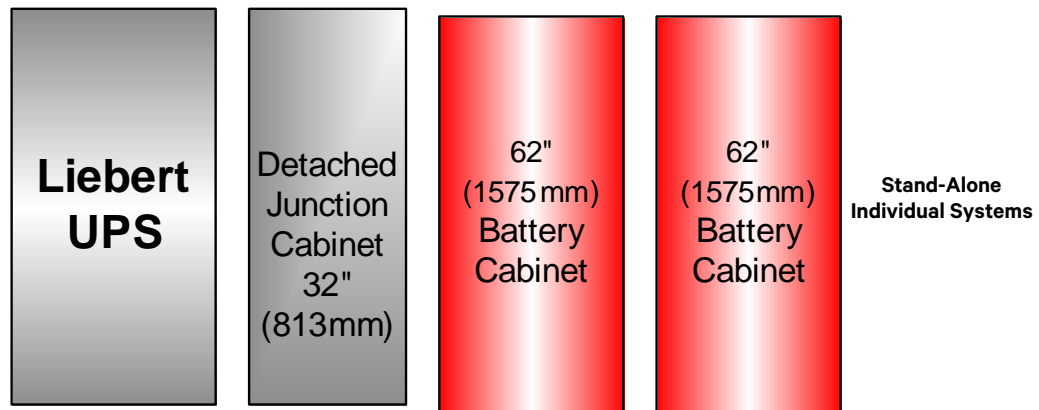


Figure 12 Front-terminal battery system configuration—Battery cabinets not attached to UPS or each other, Liebert eXL™, Liebert NX™ and Liebert NXL™



### 2.3 CABLE ENTRY

Cables may enter the battery cabinet from the top or bottom. Cable entry is made possible by installing conduit to the removable plate fitted at the top or bottom. See **3.0 - Installation Drawings**.

### 2.4 POWER CONNECTION

Depending on the site layout, the battery cabinets can be cabled several ways. See **Figures 3** through **7** for top-terminal battery systems and **Figures 8** through **12** for front-terminal battery systems.

#### NOTICE

Risk of improper cable connections. Can cause equipment damage.

Cables between the batteries and the UPS should be run in matched pairs, positive-with-negative, within each conduit or cable run.

Grouping like-polarity cables together (i.e., positive-with-positive and negative-with-negative) can cause stress or damage to the cables, conduit or buswork.

#### 2.4.1 Connected System

For cabinets ordered as connected (battery cabinets will bolt to each other), the positive and negative busbars are connected between battery cabinets with the supplied busbar connector extensions. See **Figure 33**

### 2.4.2 Connected or Stand-Alone Arrangement

For battery cabinets that connect to a Liebert UPS, (see **Figures 3** through **12**), cables will run from the positive and negative busbars of the adjacent battery cabinet to the positive and negative DC connections of UPS. For battery cabinets that are connecting to a Liebert junction cabinet (see **Figures 3** through **12**), busbars will be connected from the positive and negative busbars of the adjacent battery cabinet to the positive and negative DC connections of the junction cabinet.

For systems with the cabinets bolted to each other but not connected to a Liebert UPS, the factory-supplied cables can run internal to the cabinets.

For systems with the cabinets not bolted to each other, the cables must be run outside the cabinets. The customer must supply all the interconnecting cables and hardware. For cabinets that are ordered as stand-alone, the customer must supply all the interconnecting cables and hardware. See the UPS installation manual for current ratings and recommended cable sizes.

### 2.4.3 Grounding

For cabinets that have been ordered as connected or attached, the ground cables and hardware will be supplied. See **Figure 34** for location of cabinet-to-cabinet grounding.

For cabinets ordered as detached or stand-alone, customer must supply the cables and hardware. See the terminal detail drawings for the ground busbar's location.

## 2.5 CONTROL CONNECTIONS

Each Liebert battery cabinet contains a Battery Interface Board (BIB). See **3.0 - Installation Drawings**. All cabinets in a system must have their Battery Interface boards connected in series. See **Figures 18**, through **27** and **Figures 32** through **49** for battery cabinet details.

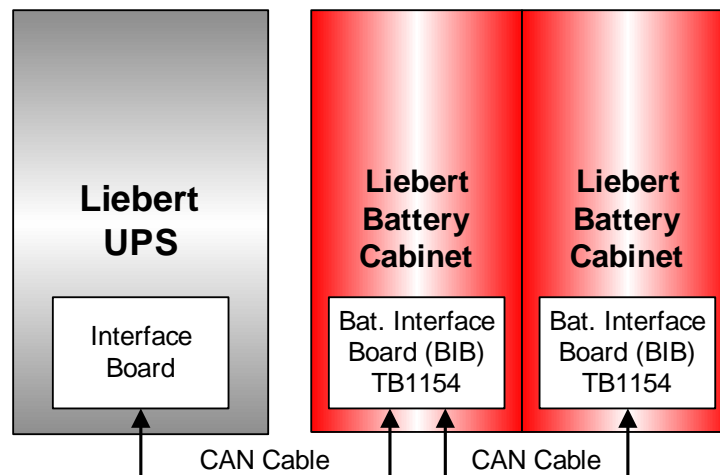
Use Belden 9156 equivalent wire. Total length of cable from UPS to all battery interface connections must be less than 1000 ft. (300m). All interconnecting cables and hardware for connected cabinets is factory-provided.



#### NOTE

*Care must be taken to route the control cables away from high-voltage cables and busbars.*

**Figure 13 Control cable layout—Liebert UPS to Liebert battery cabinet**



#### NOTICE

Risk of improper installation. Can cause equipment damage.

During system commissioning, Vertiv Liebert Services will set the jumpers on the (External Interface Board) EIB and the BIB. If another battery cabinet is added to the system after commissioning, it is imperative that Liebert Services reset the jumpers on the EIB board and the BIB board.

### 2.5.1 Liebert eXL™—UPS Control Contacts with Battery Cabinet

The battery interface board in the battery cabinet connects to TB1154 in the Liebert eXL. **Table 1** shows the contacts used to communicate between the UPS module and battery cabinets or module battery disconnects.

**Table 1 Liebert eXL UPS control contacts to battery interface boards**

Terminal Block	Pin	Connects to (Description of External Item)	Maximum Voltage	Maximum Current
TB1154	1	CAN +24V	24VDC	2A
	2	CAN Common		
	3	CANbus High		
	4	CANbus Low		

1. To prevent signal interference, low voltage (<48V) and low current (5A) cable groups should be run in separate grounded conduit from high voltage or high current cable groups.
2. All external wiring furnished by others.
3. All wiring must be in accordance with national and local electrical codes.
4. The maximum length must take into account all battery communication connections in the system.

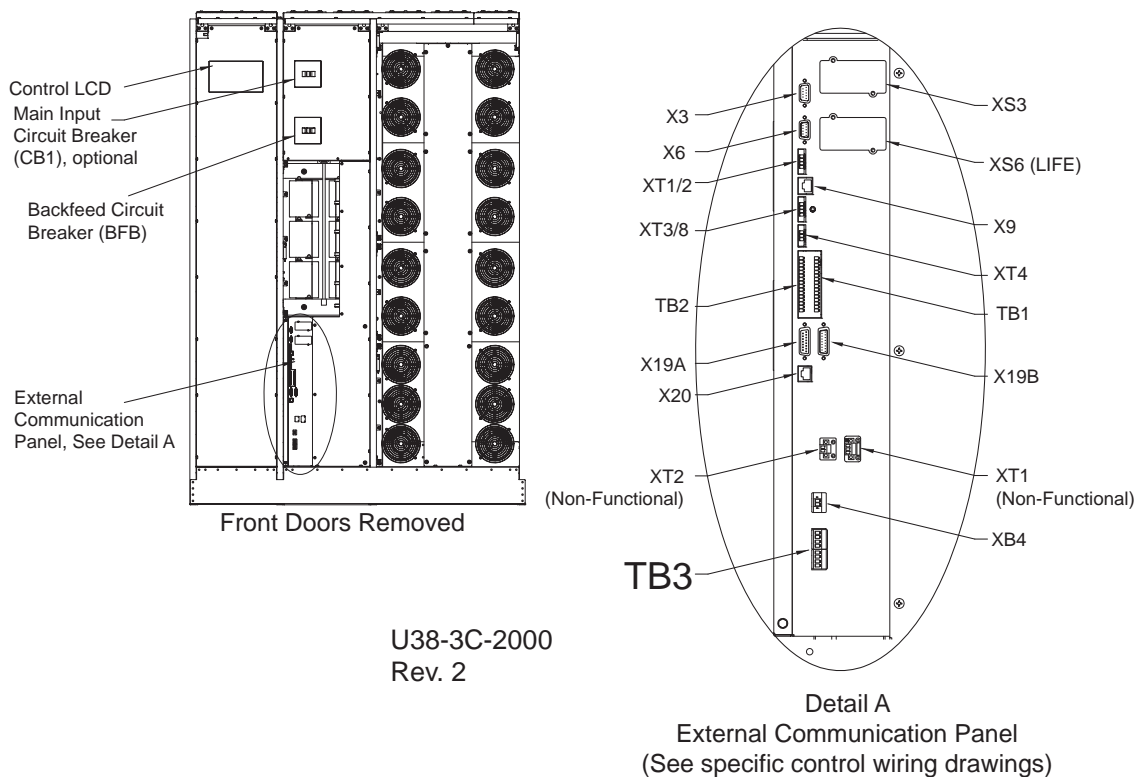
### 2.5.2 Liebert NX™—UPS Control Contacts with Battery Cabinet

The battery interface board in the battery cabinet connects to TB3 in the Liebert NX. **Table 2** shows the contacts used to communicate between the UPS module and battery cabinets or module battery disconnects. See **Figures 14** and **15** for TB3's location on the front of the Liebert NX.

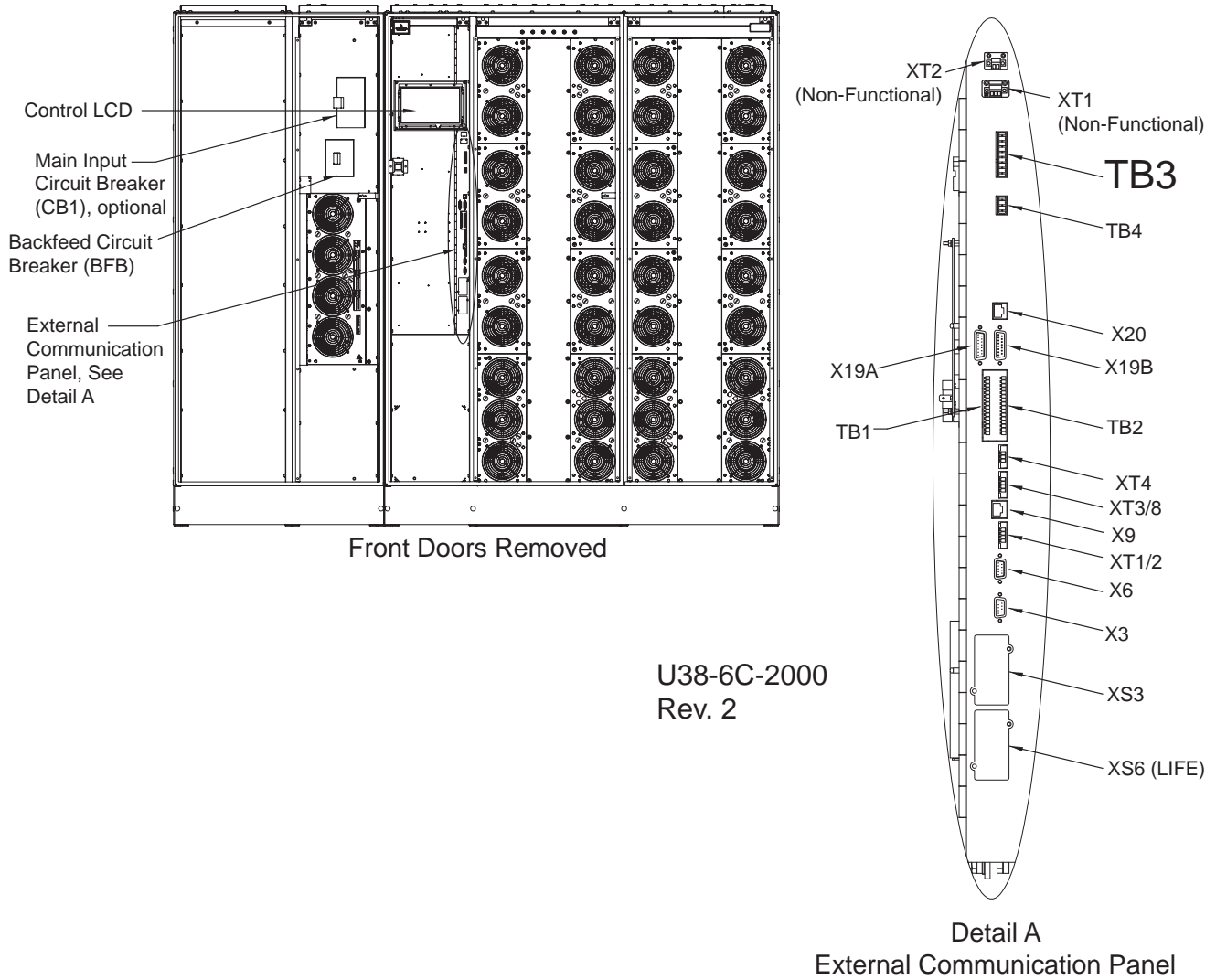
**Table 2 Liebert NX UPS control contacts to battery interface boards**

Terminal Block	Pin	Connects to (Description of External Item)
TB3	1	CAN +24V - Battery Interface Board TB1154-1
	2	GND - Battery Interface Board TB1154-2
	3	CANbus High - Battery Interface Board TB1154-3
	4	CANbus Low - Battery Interface Board TB1154-4

**Figure 14 TB3 location—225-300kVA Liebert NX™, SMS and 1+N multi-module unit with static bypass**



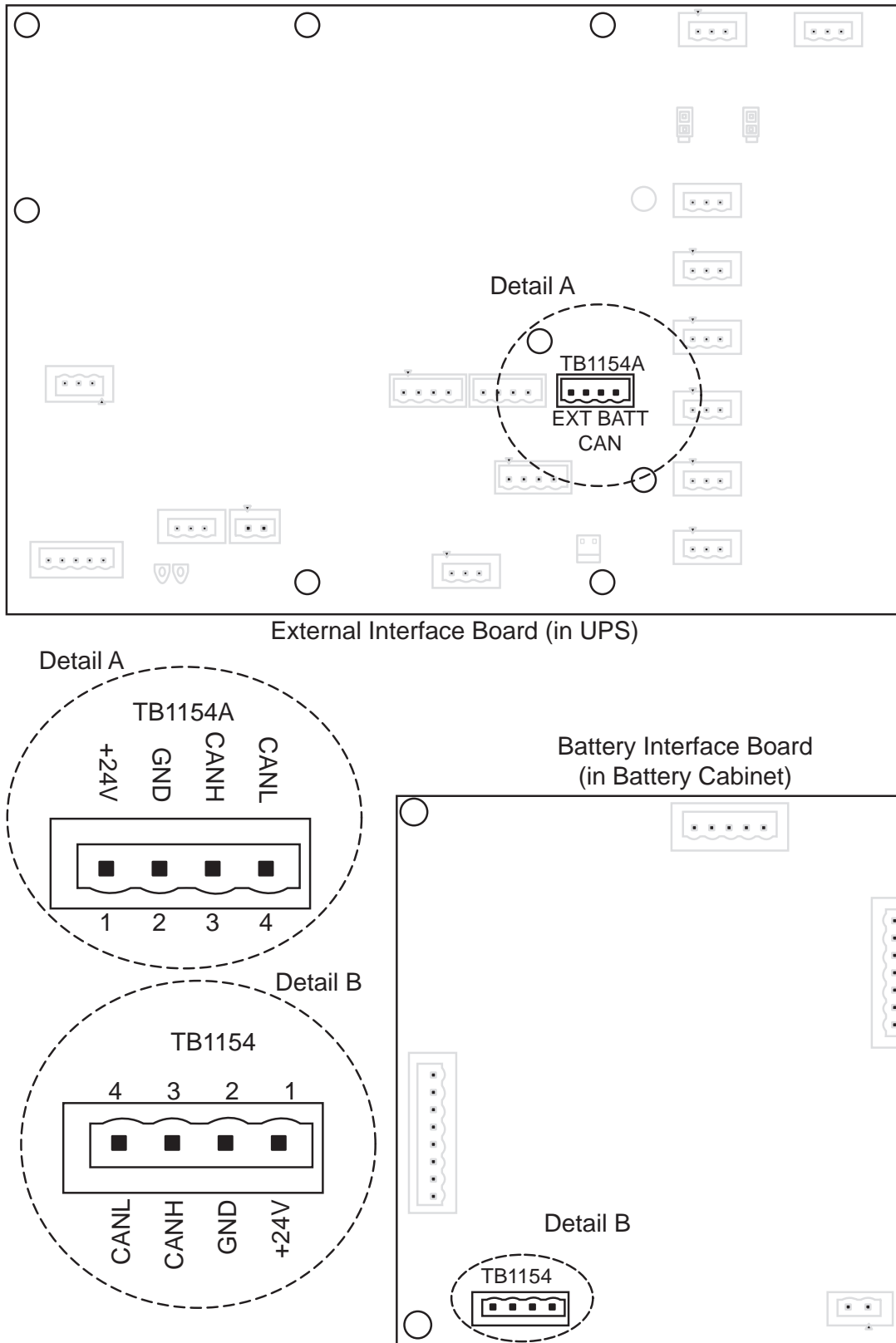
**Figure 15 TB3 location—400-600kVA Liebert NX™, SMS and 1+N multi-module unit with static bypass**



### 2.5.3 Liebert NXL™—UPS Control Contacts with Battery Cabinet

The battery interface board in the battery cabinet connects to TB1154A in the Liebert NXL. **Figure 16** shows the contacts used to communicate between the UPS module and battery cabinets or module battery disconnects.

**Figure 16** Wiring external interface board in Liebert NXL to battery interface board in battery cabinet



## 2.6 ALBER® MONITORING SYSTEM—OPTIONAL

The Liebert matching battery cabinet allows installing an optional Alber battery monitoring system in the cabinet. Alber battery monitoring continuously checks all critical battery parameters, such as cell voltage, overall string voltage, current and temperature. Automatic periodic tests of internal resistance of each battery will verify the battery's operating integrity. Additional capabilities include automatic internal DC resistance tests and trend analysis providing the ability to analyze performance and aid in troubleshooting.

The Alber monitoring system is installed inside the battery cabinet (see **Figure 52**). The monitoring system is supplied by an internal transformer.

The transformer is powered from the output of the UPS the battery cabinet is supplying (see **Figure 52**).

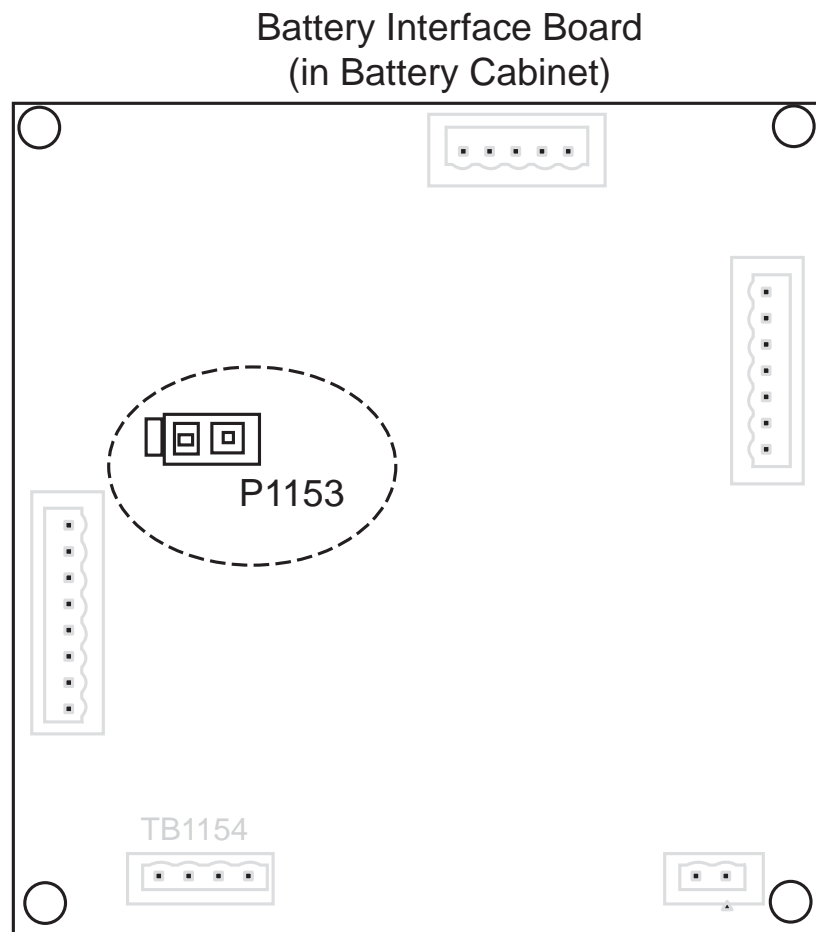
The Alber monitoring system consists of a Control Module and a Battery Module (see **Figure 50**). One Control Module can monitor up to eight battery cabinets with a Battery Module installed. The battery cabinet with the Control Module (Battery Cabinet #1) must be installed in the position closest to the UPS.

For details about operating the Alber system, see the Alber Monitoring System manual, available at the Liebert Web site, [www.liebert.com](http://www.liebert.com)

## 2.7 EXTERNAL BATTERY ROOM TEMPERATURE SENSOR—OPTIONAL

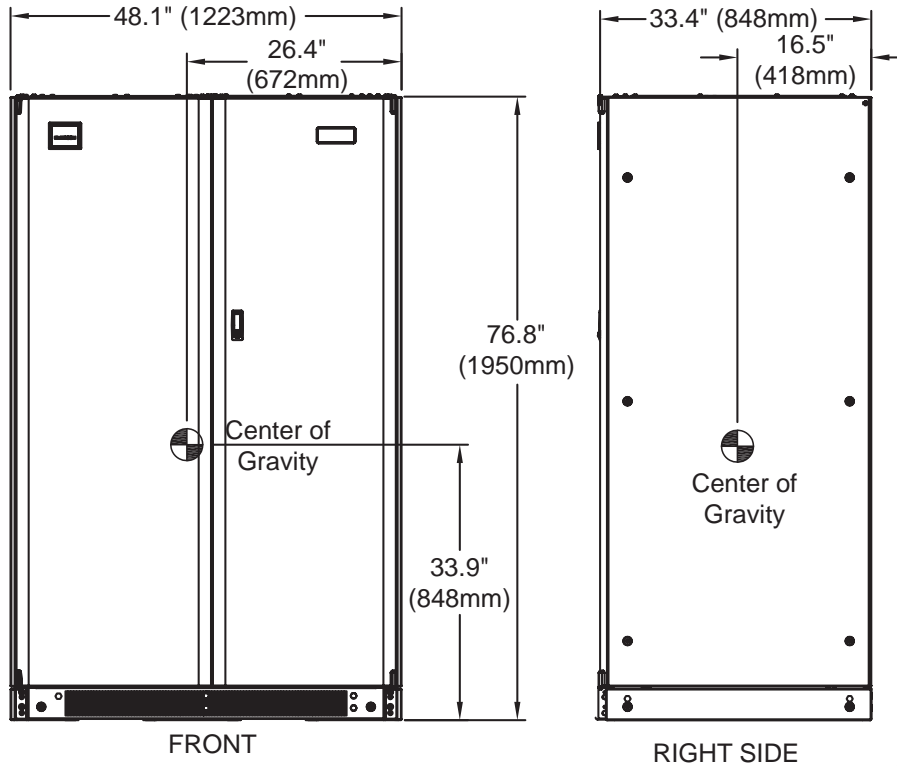
For systems that do not use Liebert battery cabinets, an optional temperature sensor can be installed to monitor the ambient room temperature. This sensor is connected to the BIB board (see **Figure 17**). This sensor will allow the Liebert UPS to perform temperature compensation charging.

**Figure 17 Battery temperature sensor control connection**



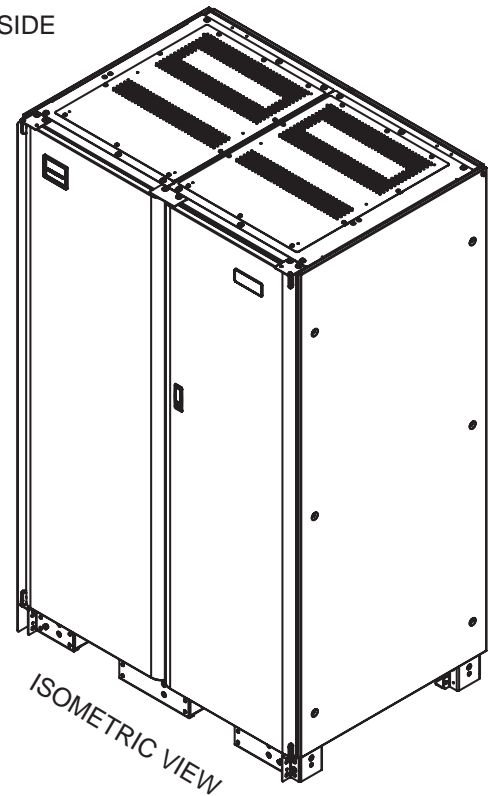
### 3.0 INSTALLATION DRAWINGS

Figure 18 Outline drawing, Liebert top-terminal, 47" (1194mm) wide battery cabinet



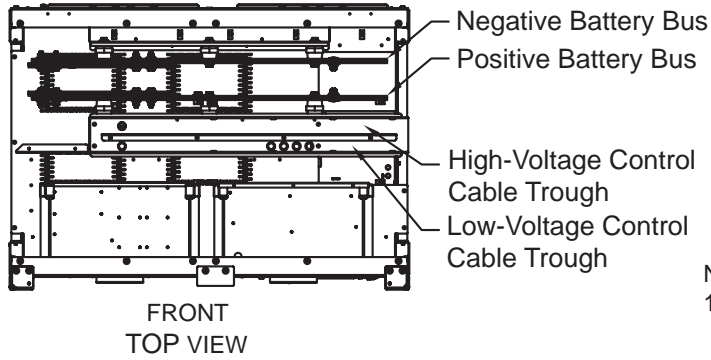
1. 24" (610mm) minimum clearance above the unit is required for air exhaust.
2. Keep cabinet within 15 degrees of vertical.
3. Top and bottom cable entry is available through removable access plates.
4. All wiring must be in accordance with national and local electrical codes.
5. Width dimension is without side panels; add 0.7" (18mm) per side where applicable.
6. Depth dimension includes the front door and rear panel.
7. Refer to the battery technical information drawing for more information.

BPP12003  
Pg. 1, Rev. 0



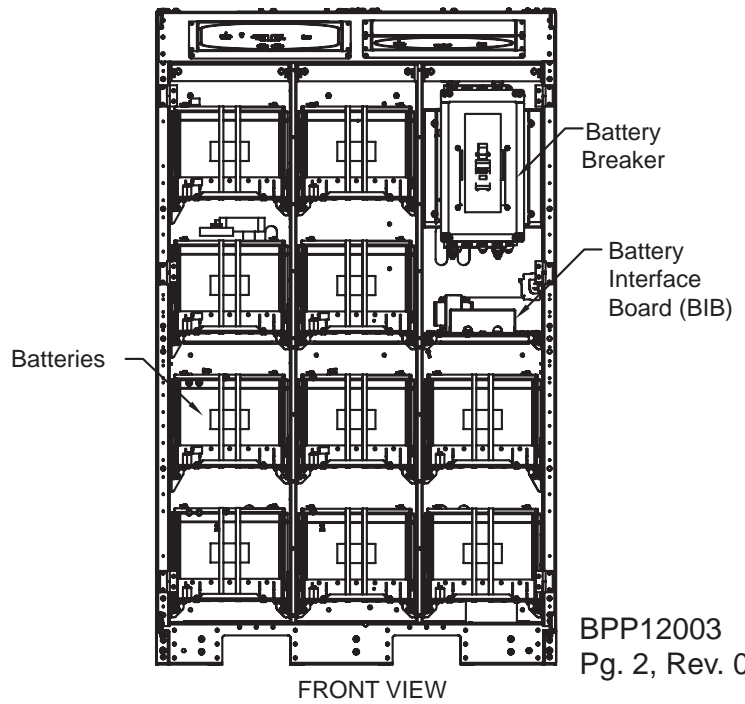
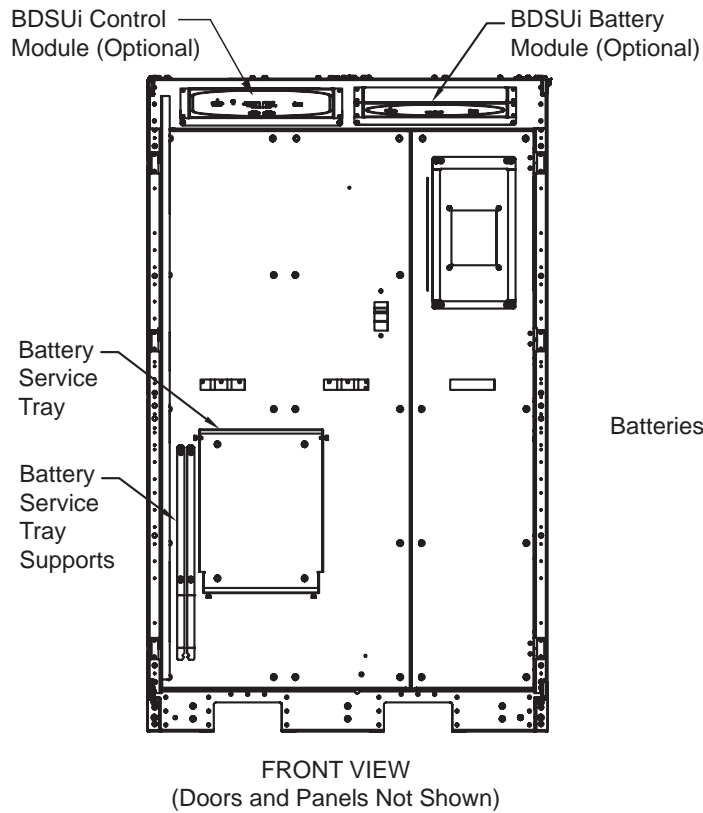


**Figure 19 Main components, Liebert top-terminal, 47" (1194mm) wide battery cabinet**



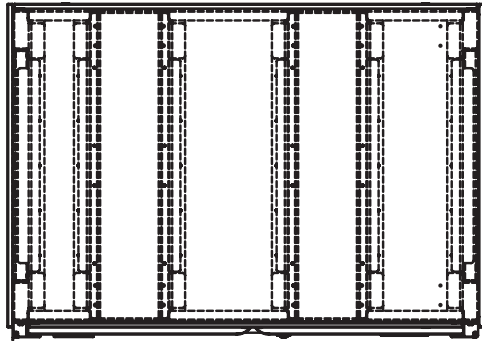
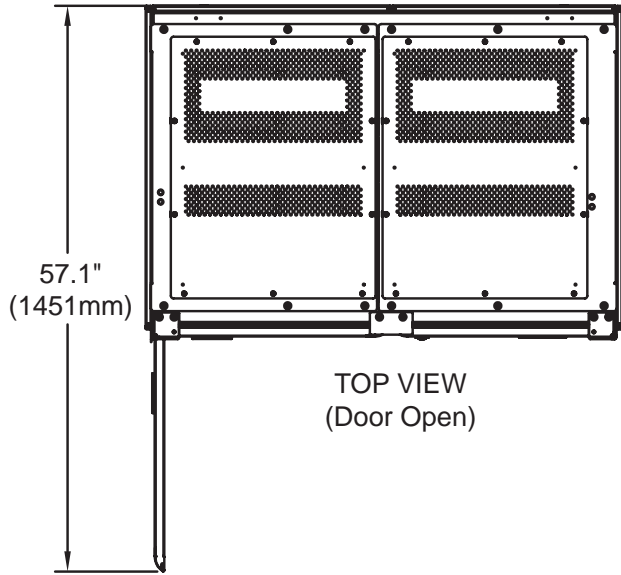
**NOTES**

1. Positive and negative battery bus typical for some versions; not included with stand-alone individual cabinet.
2. Battery service tray and supports provided with Cabinet 1.



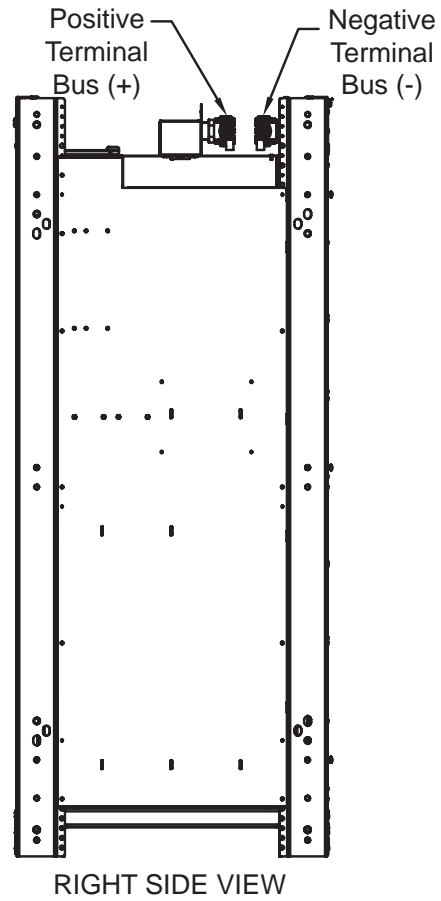
BPP12003  
Pg. 2, Rev. 0

Figure 20 Terminal details, Liebert top-terminal, 47" (1194mm) wide battery cabinet



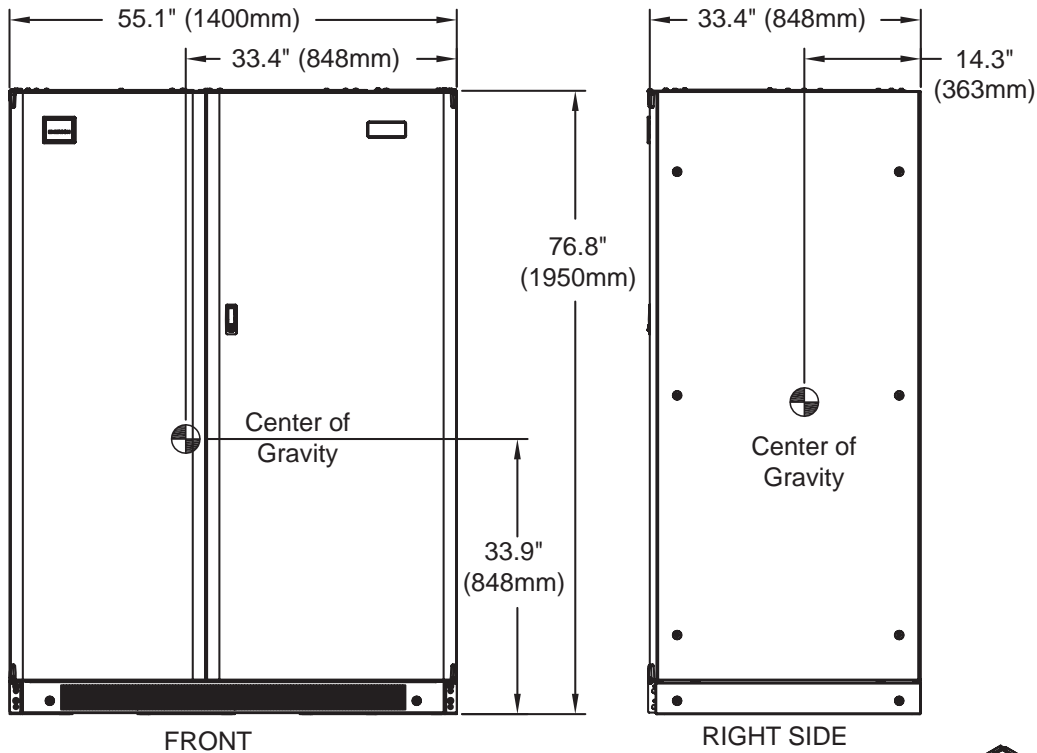
NOTES

1. Top and bottom cable entry available through removable access plates.
2. Control wiring and power wiring must be run in separate conduit.
3. All wiring must be in accordance with national and local electrical codes.



BPP12003  
Pg. 3, Rev. 0

**Figure 21 Outline drawing, Liebert top-terminal, 55" (1400mm) wide battery cabinet**



1. 24" (610mm) minimum clearance above the unit is required for air exhaust.
2. Keep cabinet within 15 degrees of vertical.
3. Top and bottom cable entry is available through removable access plates.
4. Control wiring and power wiring must be run in separate conduit.
5. All wiring must be in accordance with national and local electrical codes.
6. Width dimension is without side panels; add 0.7" (18mm) per side where applicable.
7. Depth dimension includes the front door and rear panel.
8. Refer to the battery technical information drawing for more information.

BPP12001  
Pg. 1, Rev. 0

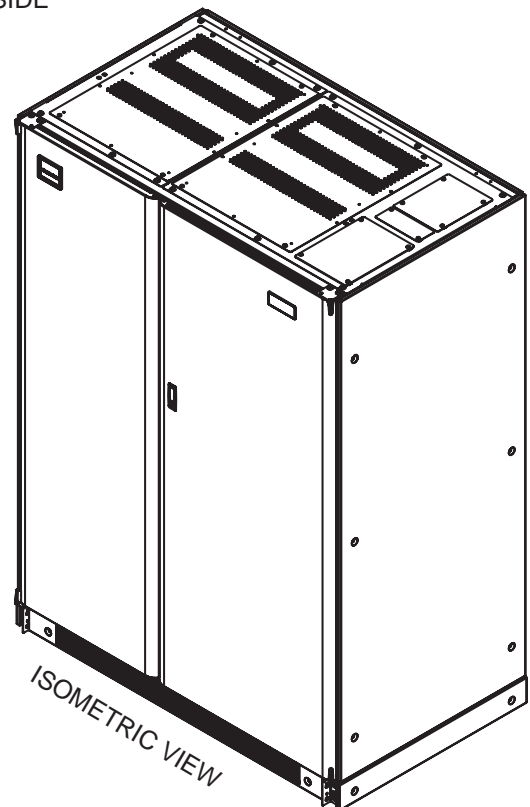
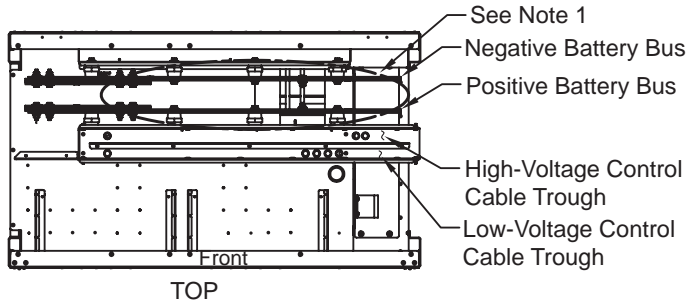
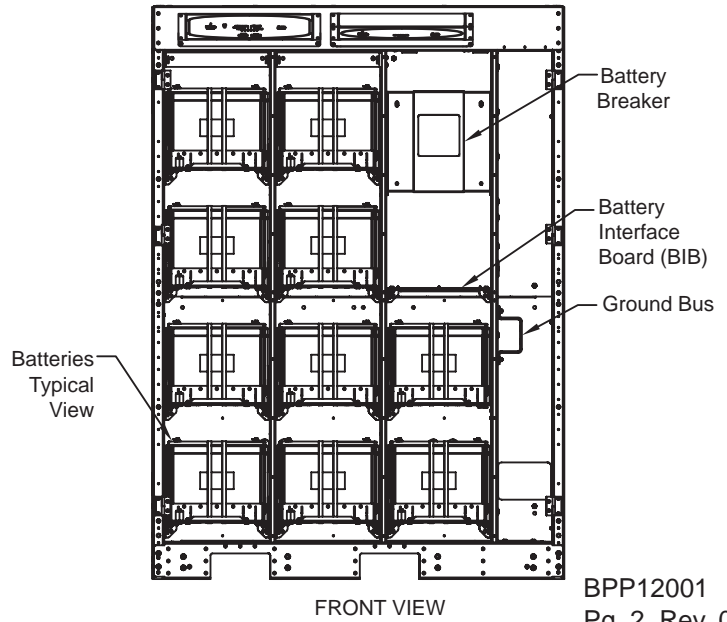
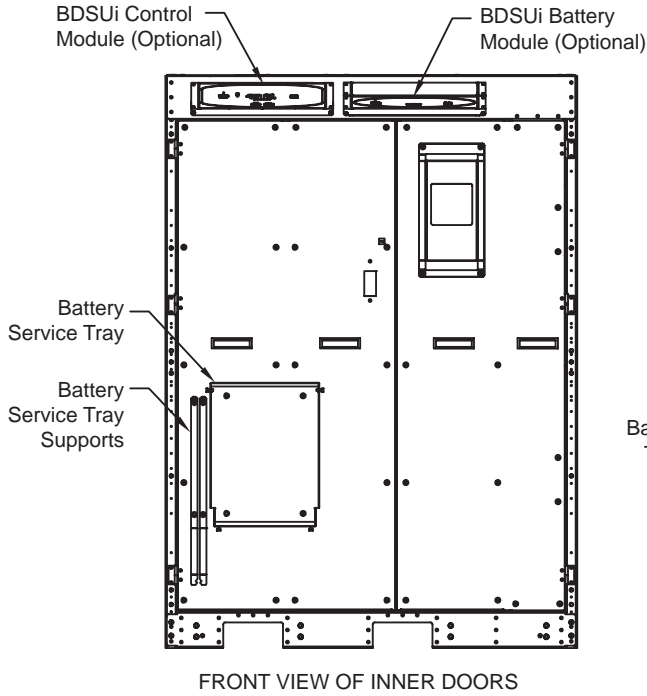


Figure 22 Main components, top-terminal, 55" (1400mm) wide battery cabinet



NOTES

1. Positive and negative battery bus typical for some versions; not included with stand-alone individual cabinet.
2. Battery service tray and supports provided with Cabinet 1.



BPP12001  
 Pg. 2, Rev. 0

**Figure 23 Terminal details, top-terminal, 55" (1400mm) wide battery cabinet**

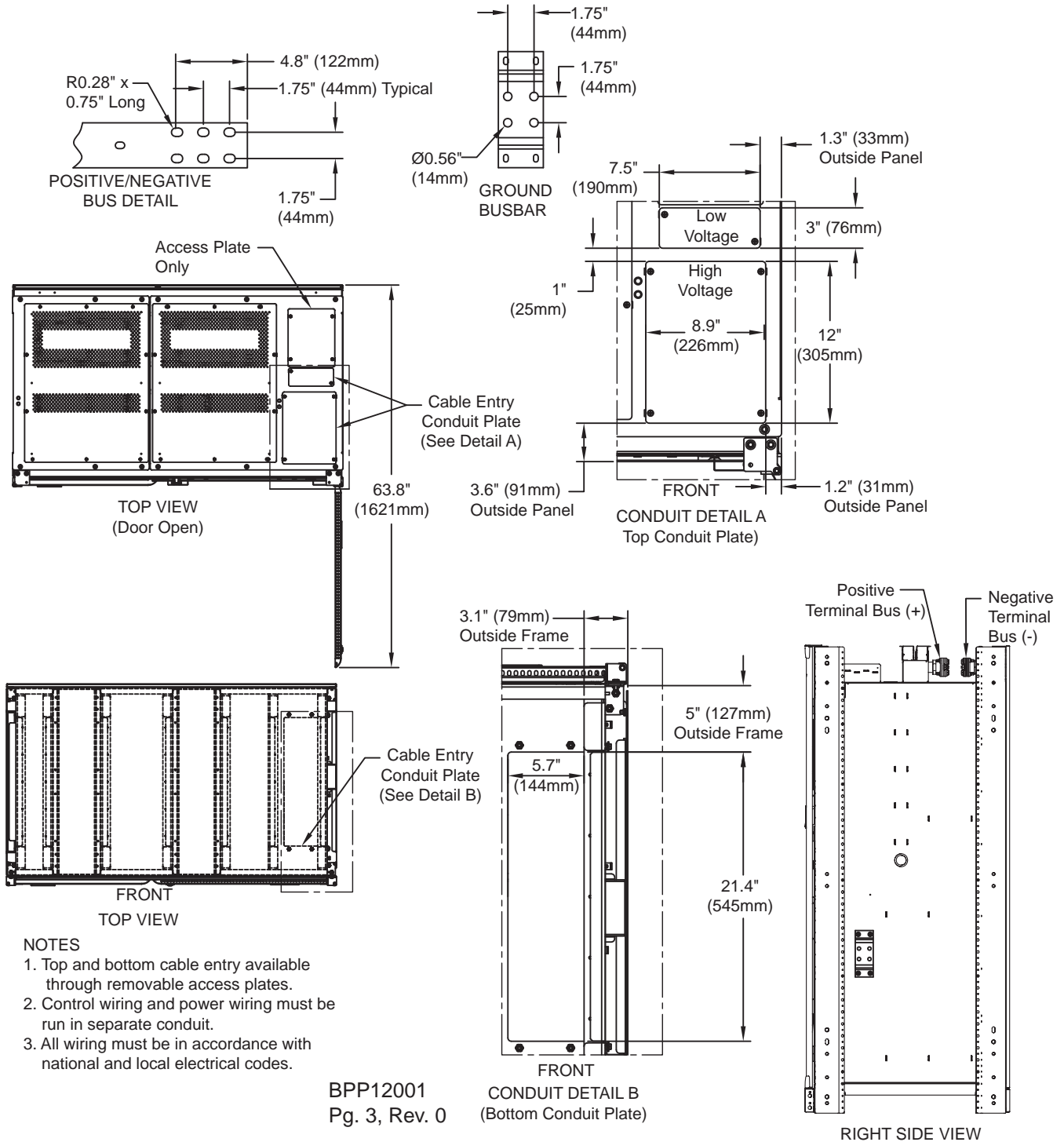
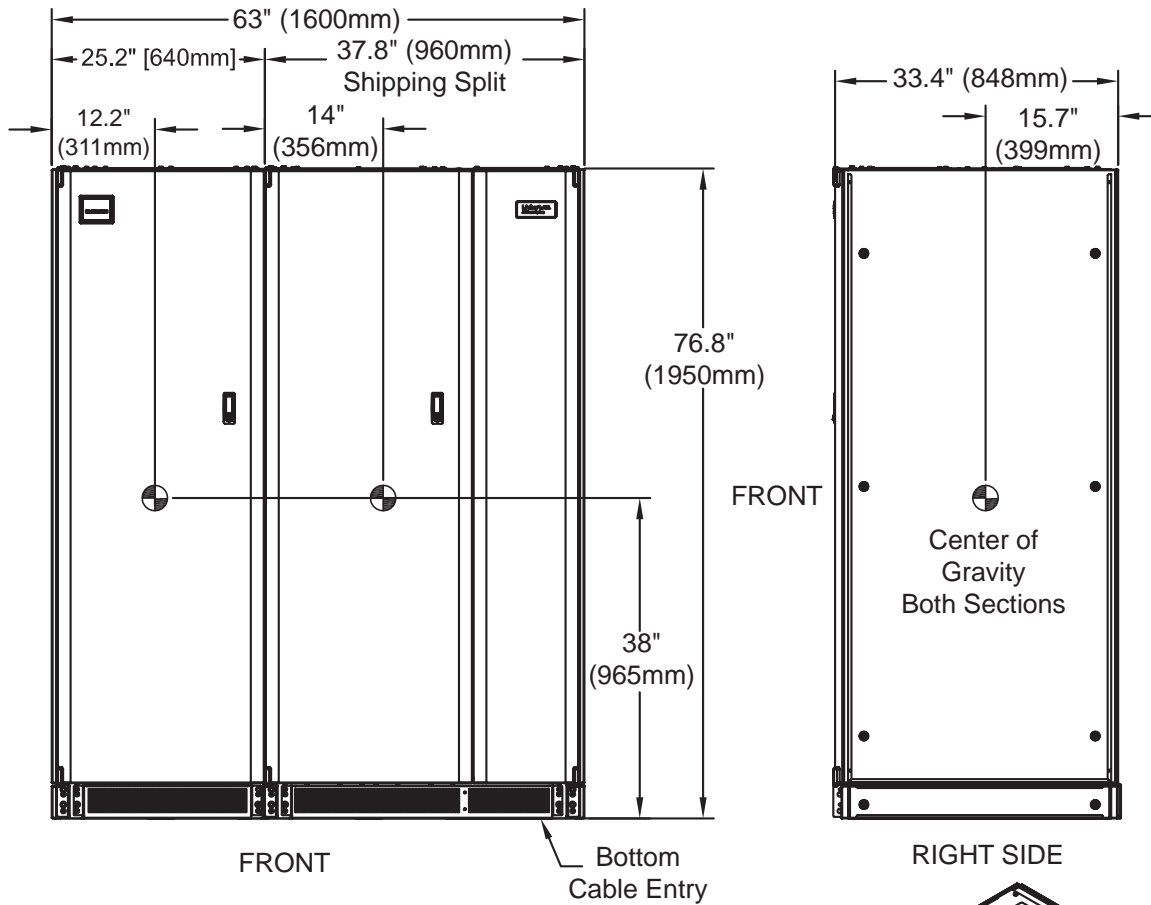
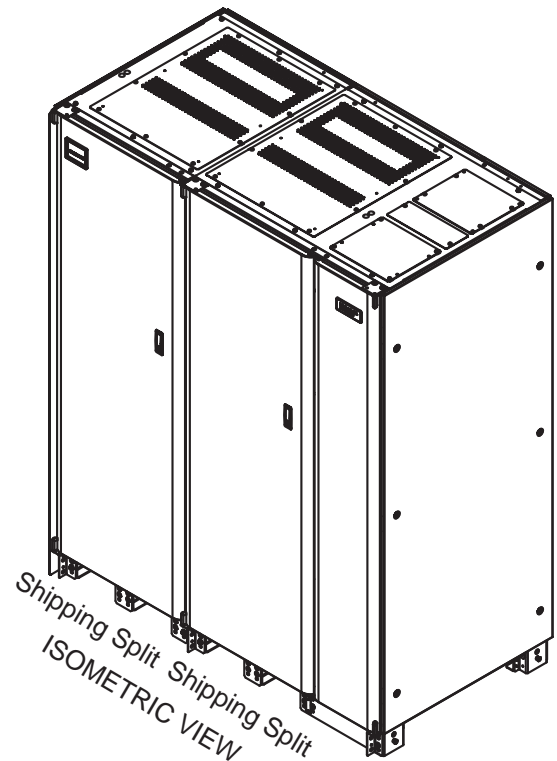


Figure 24 Outline drawing, Liebert front-terminal battery cabinet



1. 24" (610mm) minimum clearance above the unit is required for air exhaust.
2. Keep cabinet within 15 degrees of vertical.
3. Top and bottom cable entry is available through removable access plates.
4. Control wiring and power wiring must be run in separate conduit.
5. All wiring must be in accordance with national and local electrical codes.
6. Width dimension is without side panels; add 0.7" (18mm) per side where applicable.
7. Depth dimension includes the front door and rear panel.
8. Refer to the battery technical information drawing for more information.

BPP12002  
Pg. 1, Rev. 0



**Figure 25 Main components, Liebert front-terminal battery cabinet**

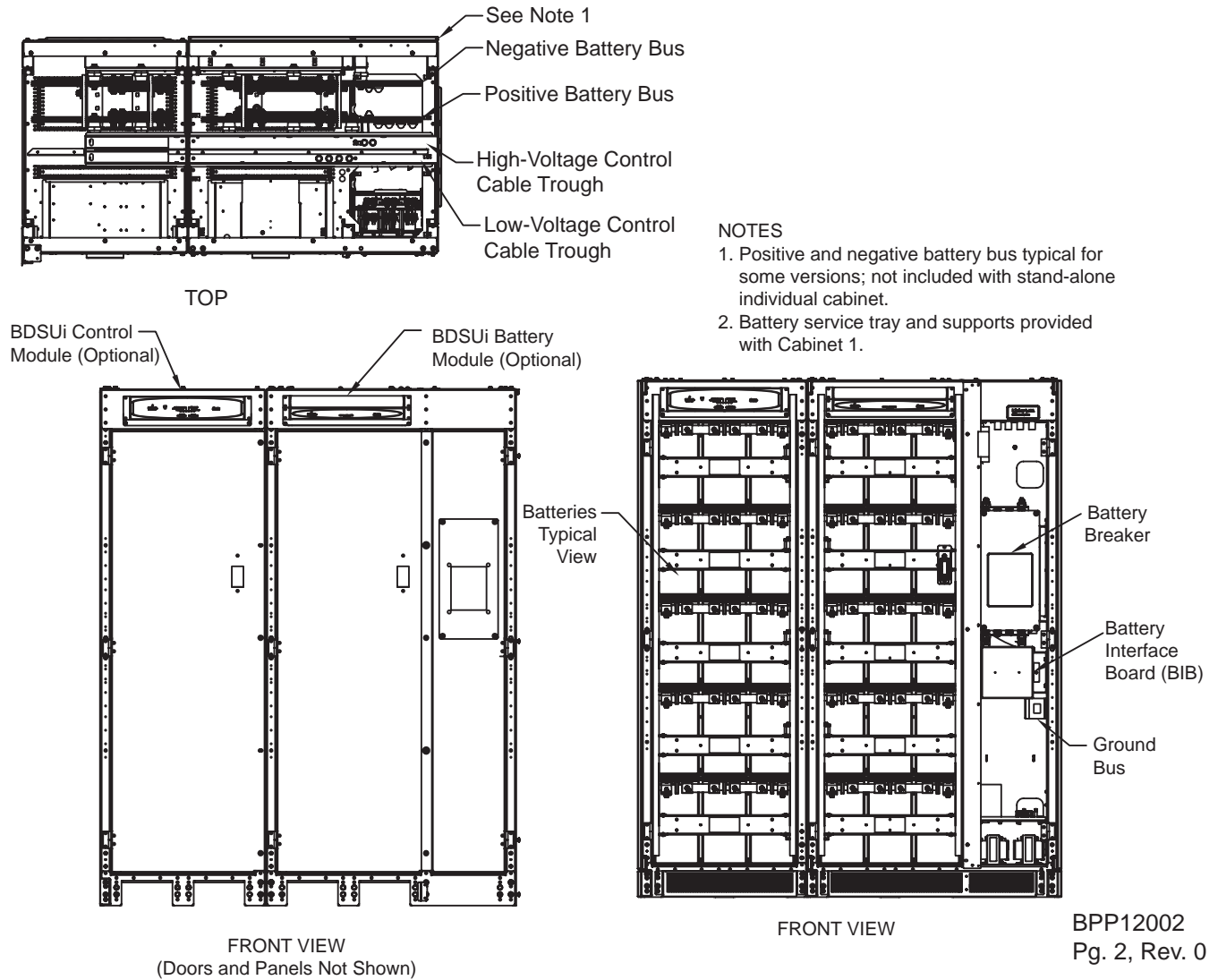
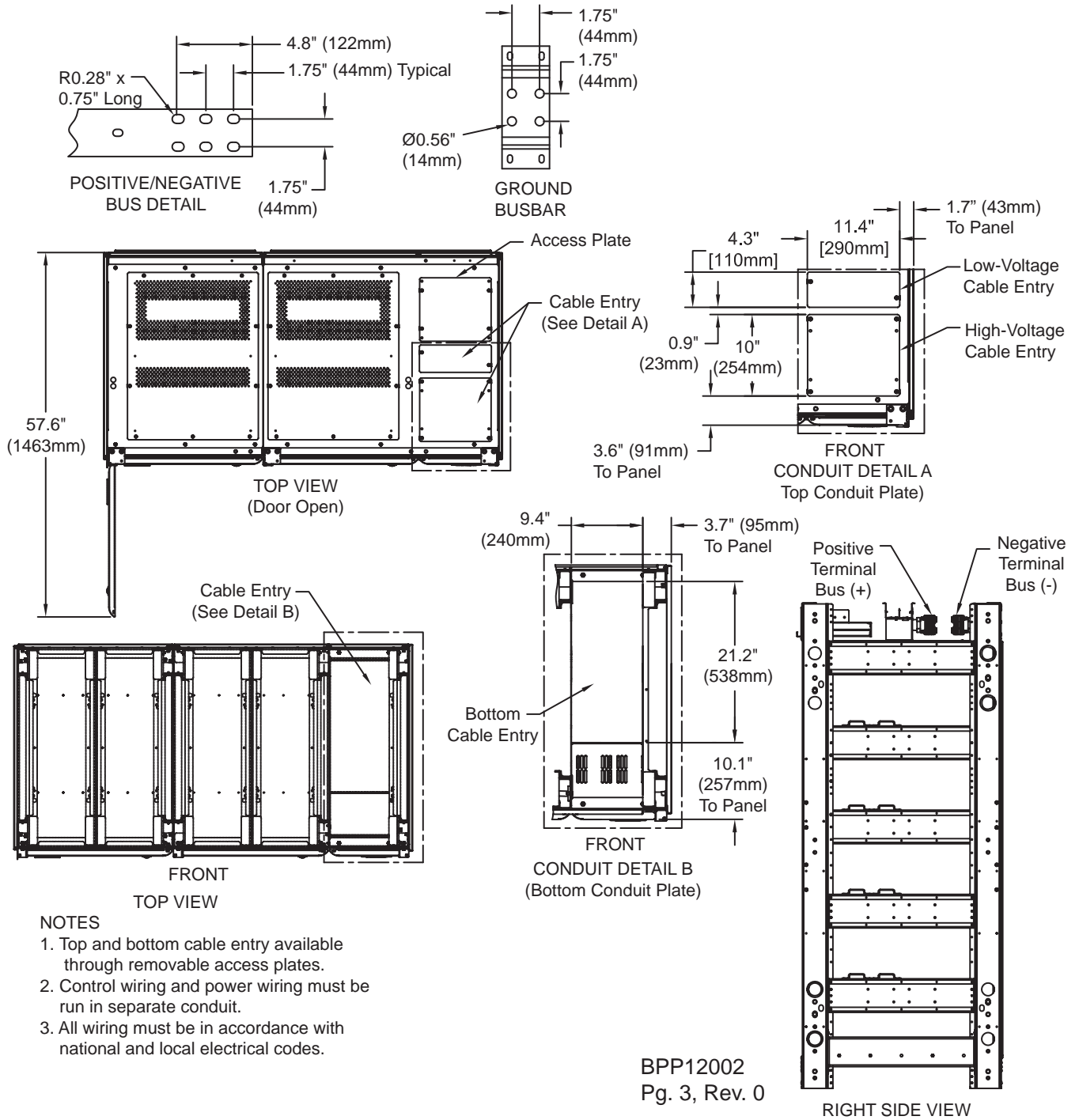


Figure 26 Terminal details, Liebert front-terminal battery cabinet





**Figure 27 Front-terminal battery cabinet shipping split**

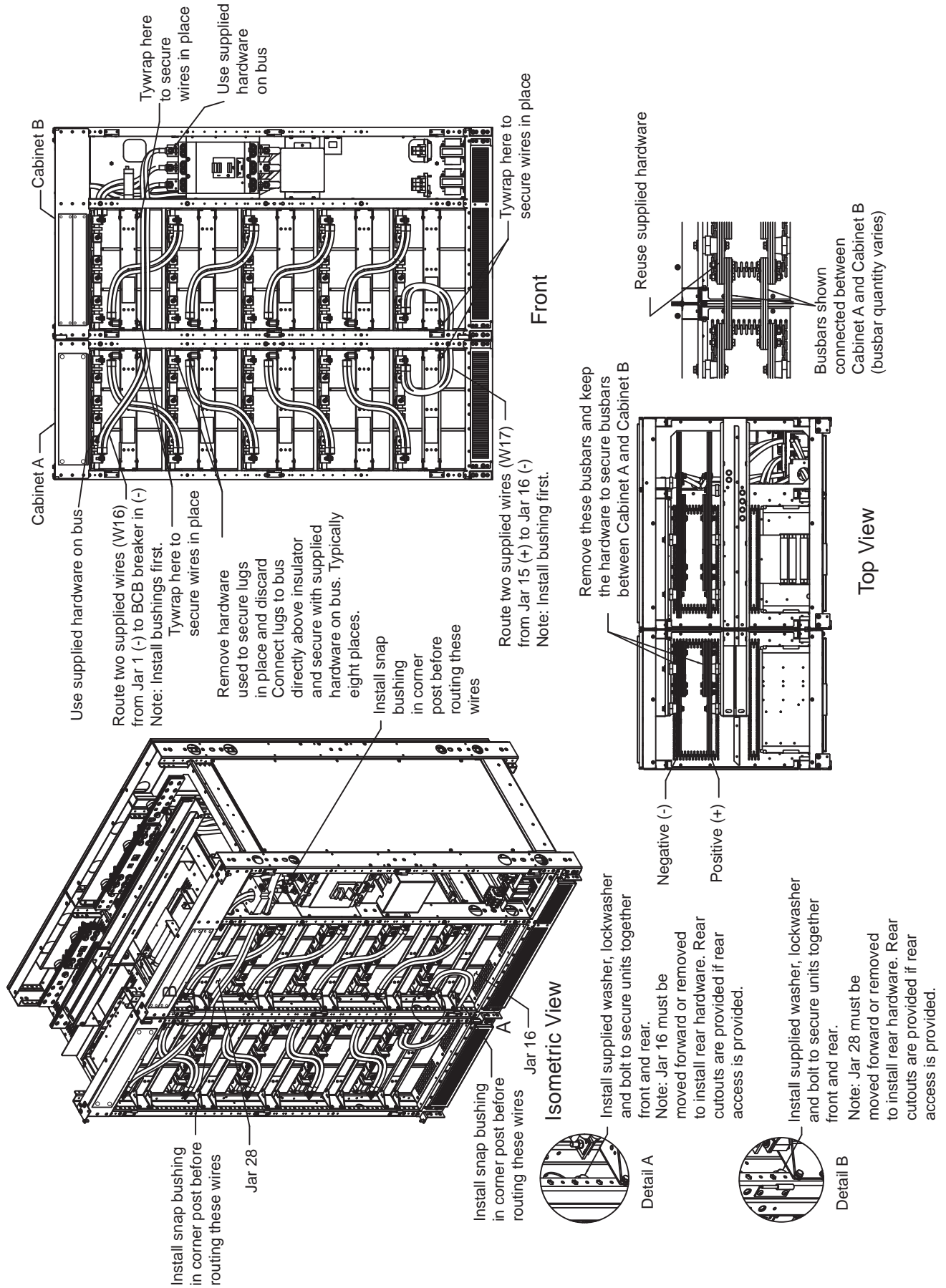
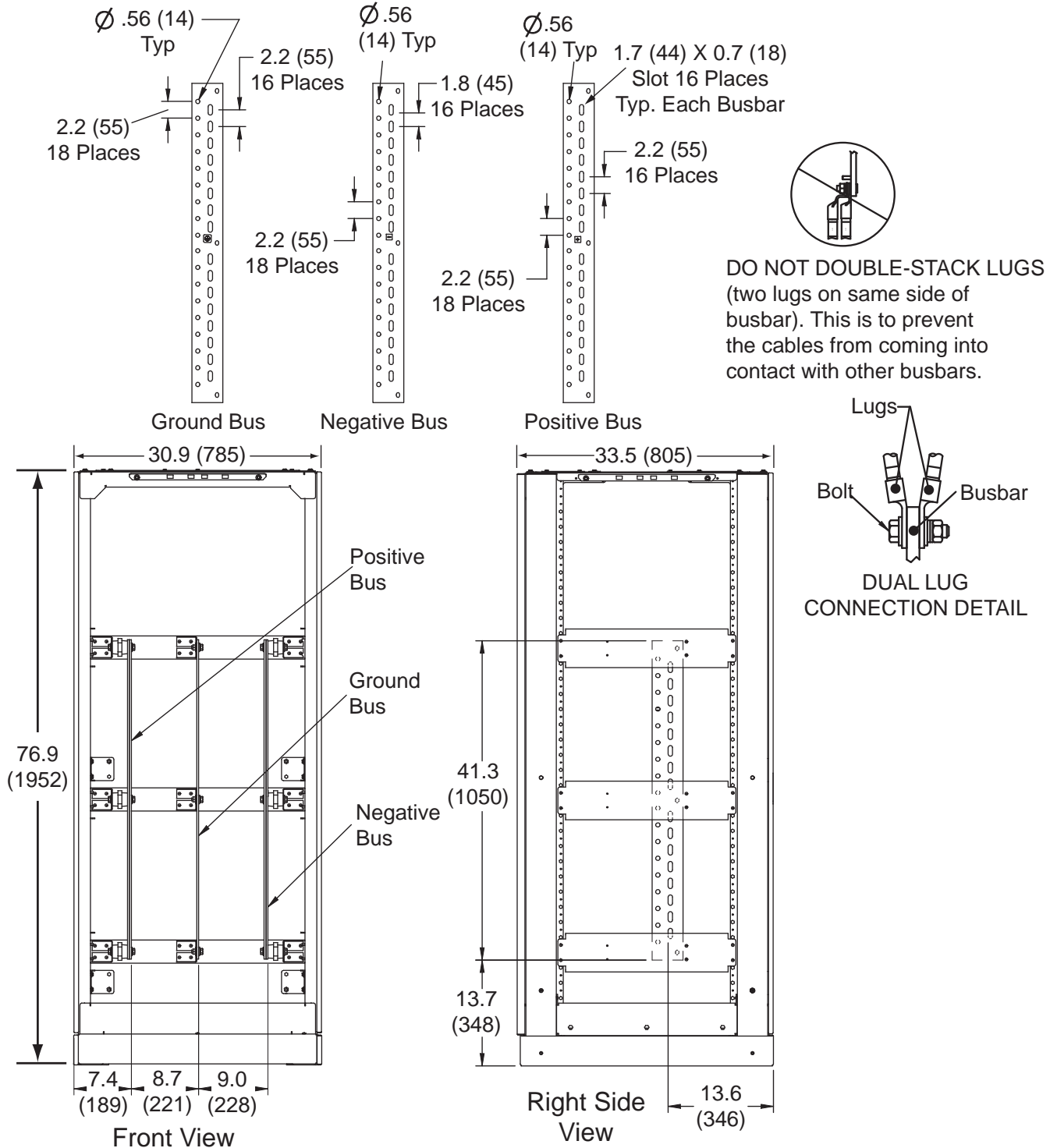


Figure 28 Liebert stand-alone 32" (813mm) junction cabinet terminal wiring



Notes

1. All dimensions are in inches (mm).
2. Control wiring and power wiring must be run in separate conduit.
3. Unless otherwise noted, use copper or aluminum conductors suitable for at least 75°C.
4. Widths are without side panels. The width is 32.1" (815mm) with side panels.
5. The depth dimension includes the front door and rear panel.

**Figure 29** Liebert attached junction cabinet—terminal details

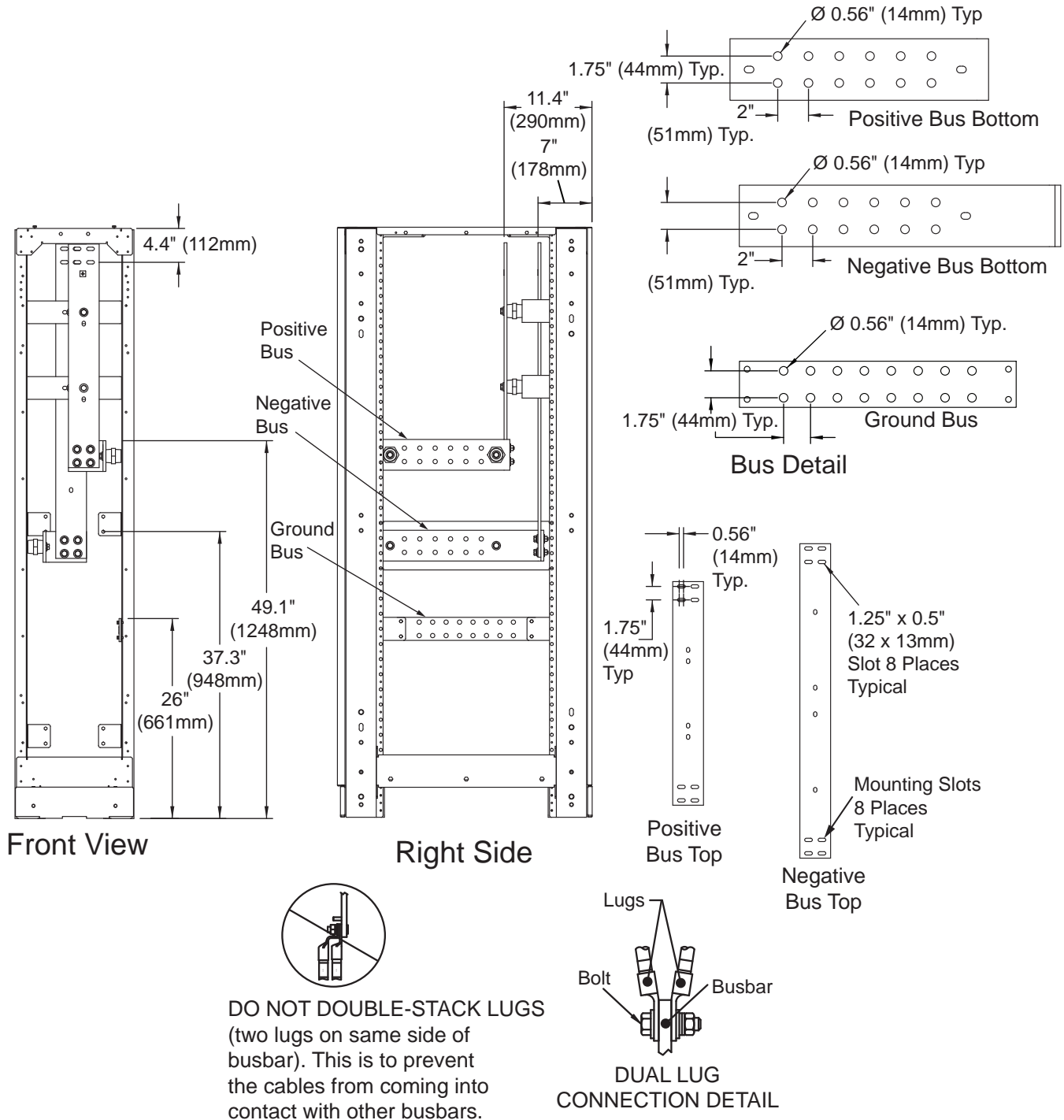
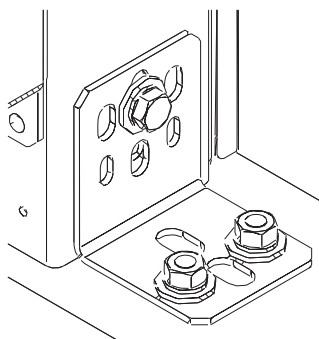
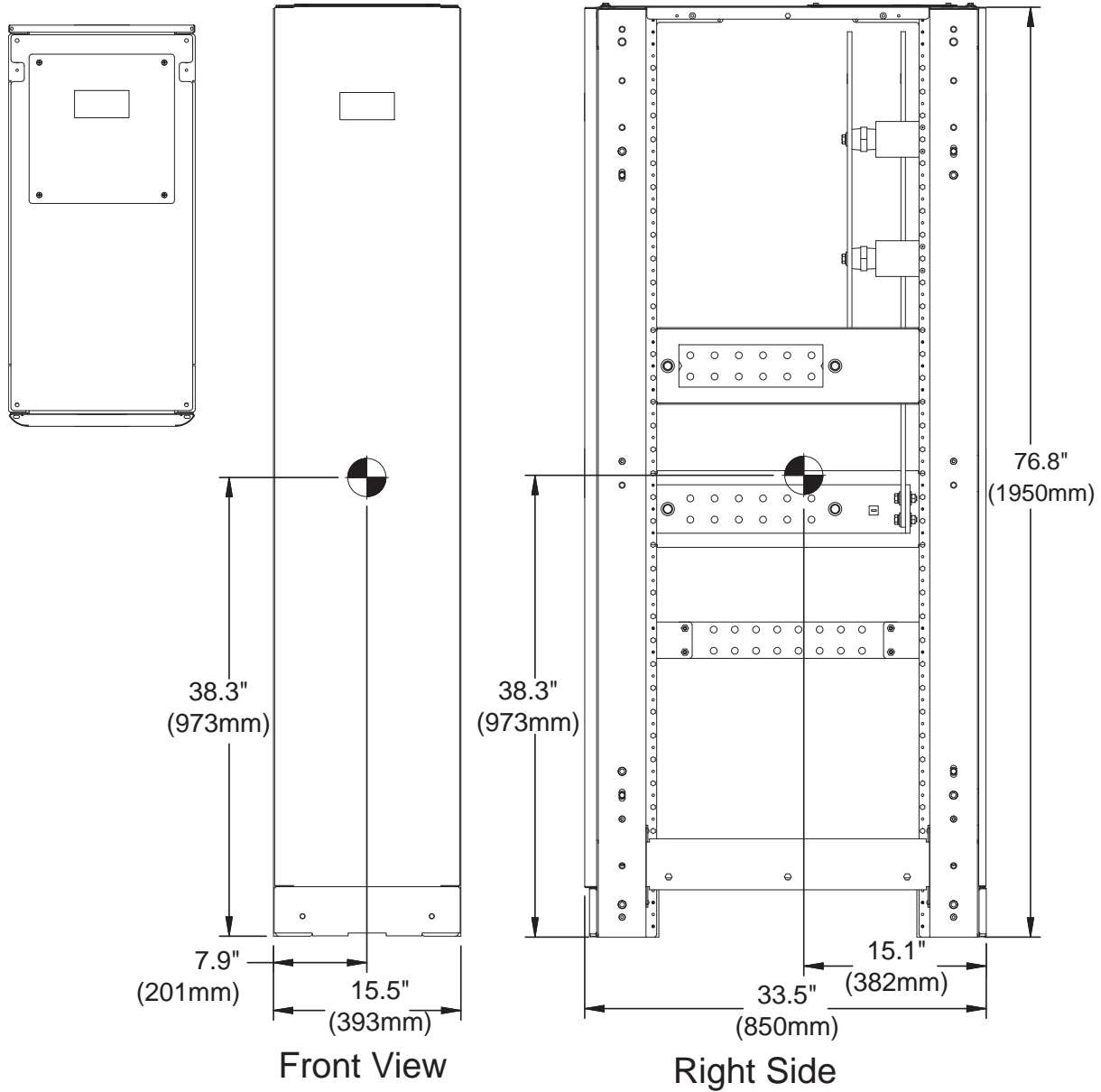


Figure 30 Liebert 15-1/2" attached junction cabinet—Outline drawing



**WARNING!**  
 Unit Removal and Unit Mobility Instructions  
 Brackets must remain attached to the frame until the unit is being placed in its final installation location. (The final installation will always require the unit to be bolted to another Liebert product.) Failure to comply with these instructions could result in equipment damage and injury to personnel.

Figure 31 17" junction cabinet junction cabinet

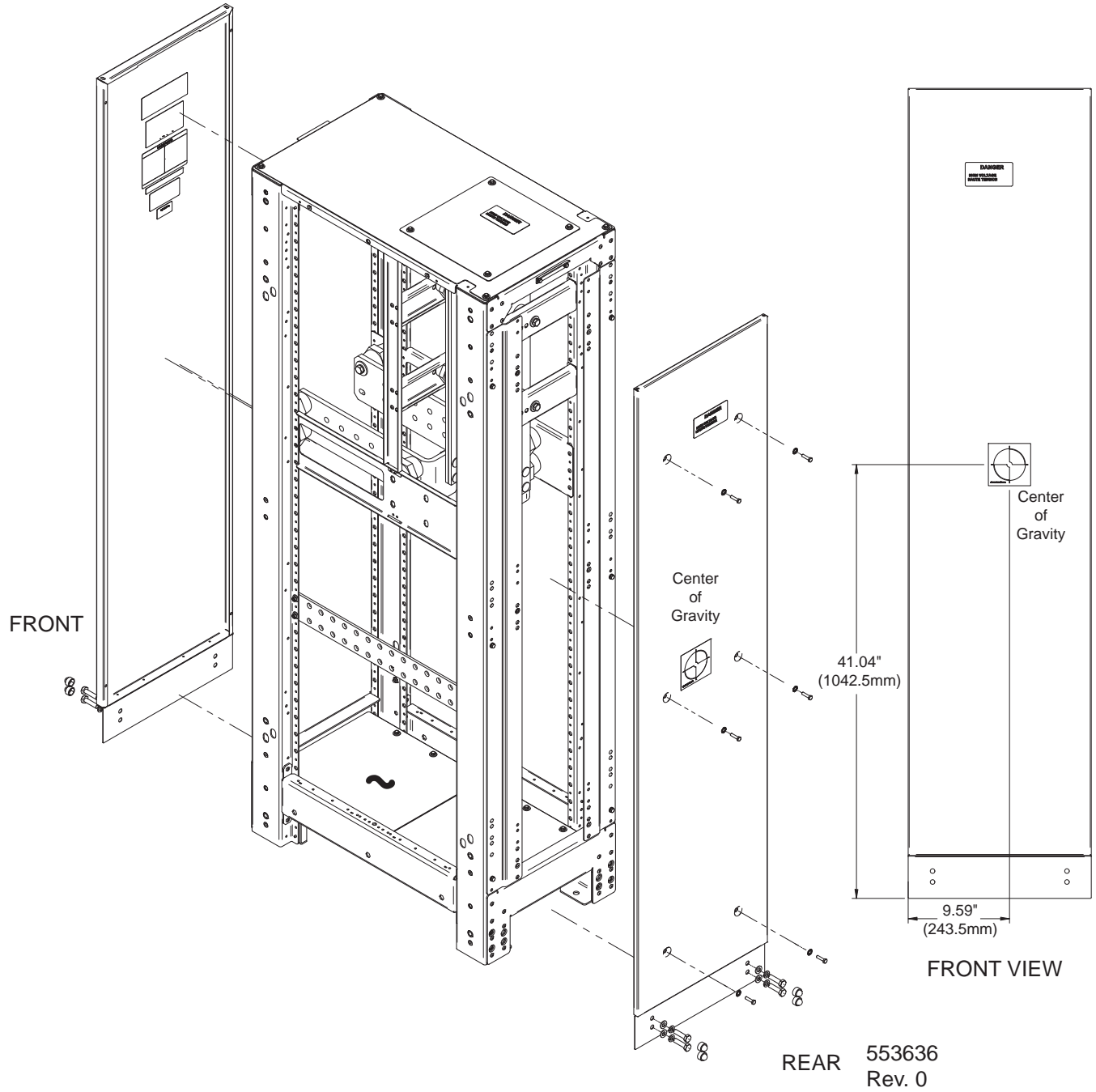
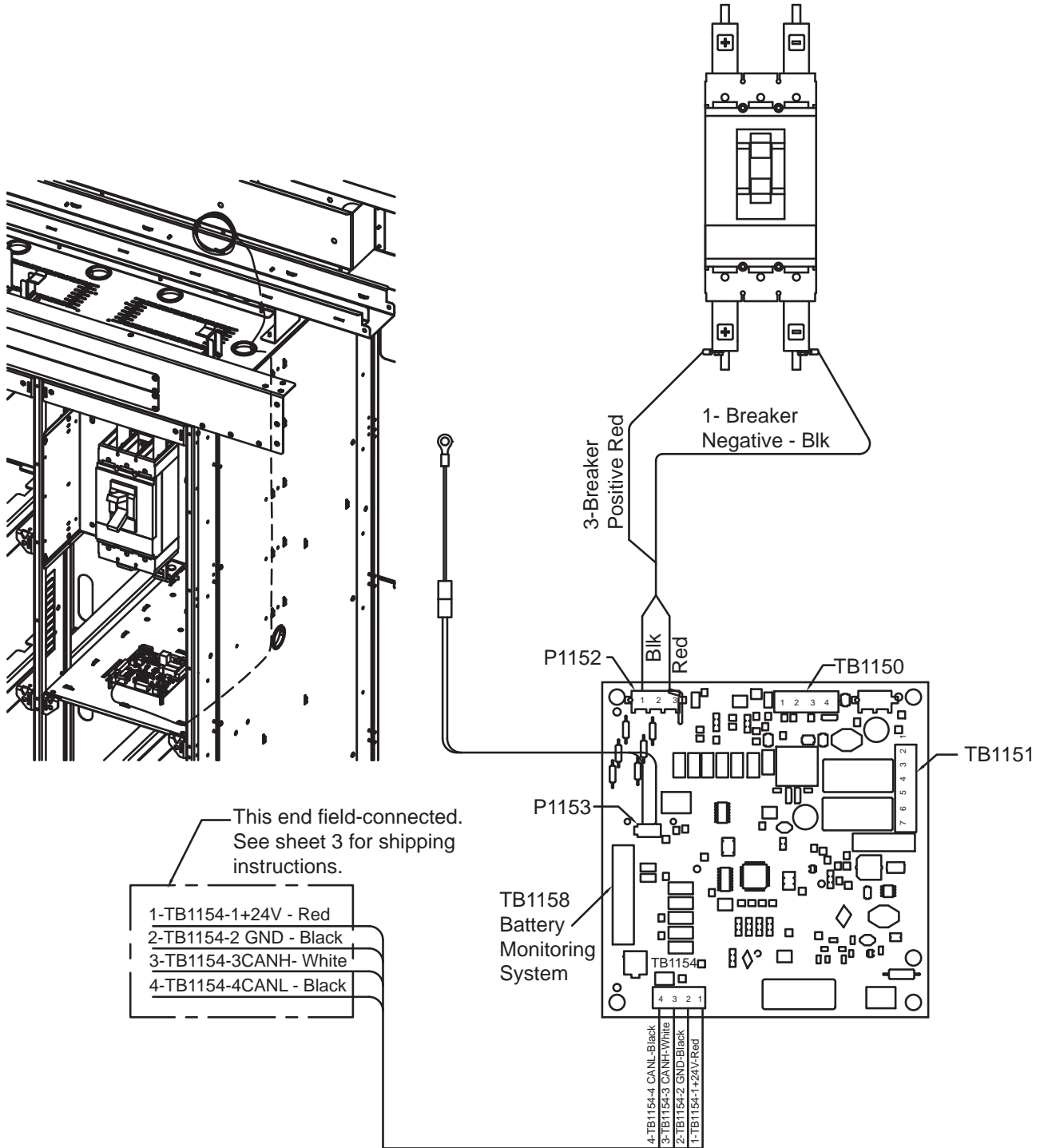
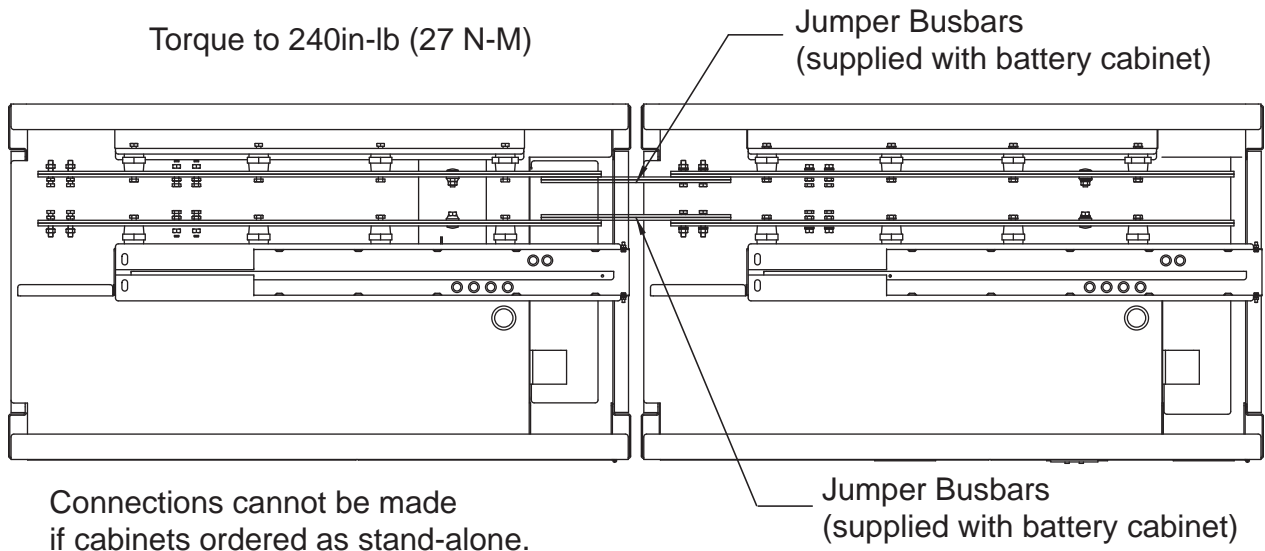


Figure 32 Liebert battery cabinet control wiring



**Figure 33 Attached battery cabinet connections**



**Figure 34 Ground strap location for connected cabinets**

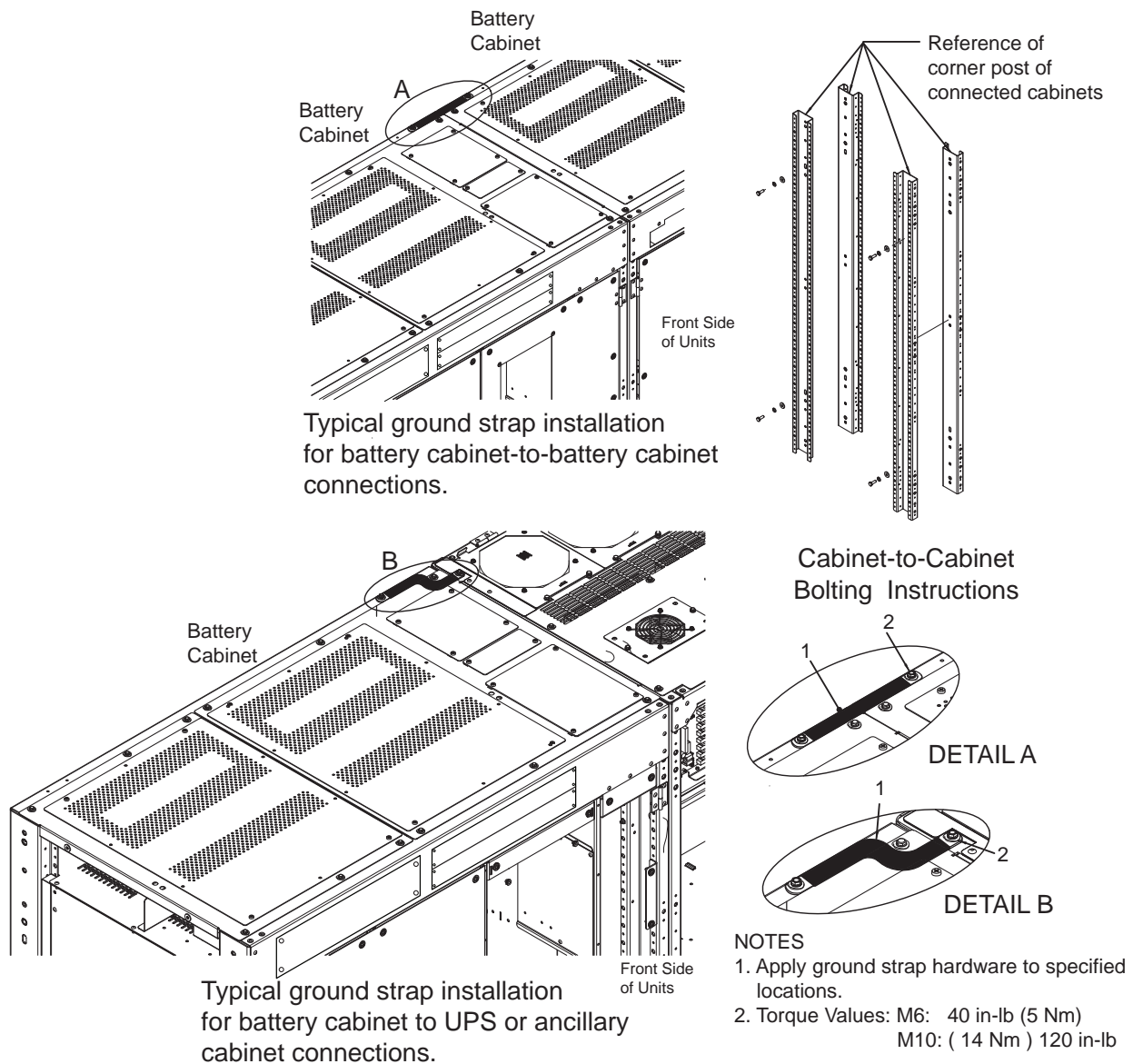


Figure 35 Top-terminal, standard width battery cabinet interconnection wiring to 250-400kVA UPS

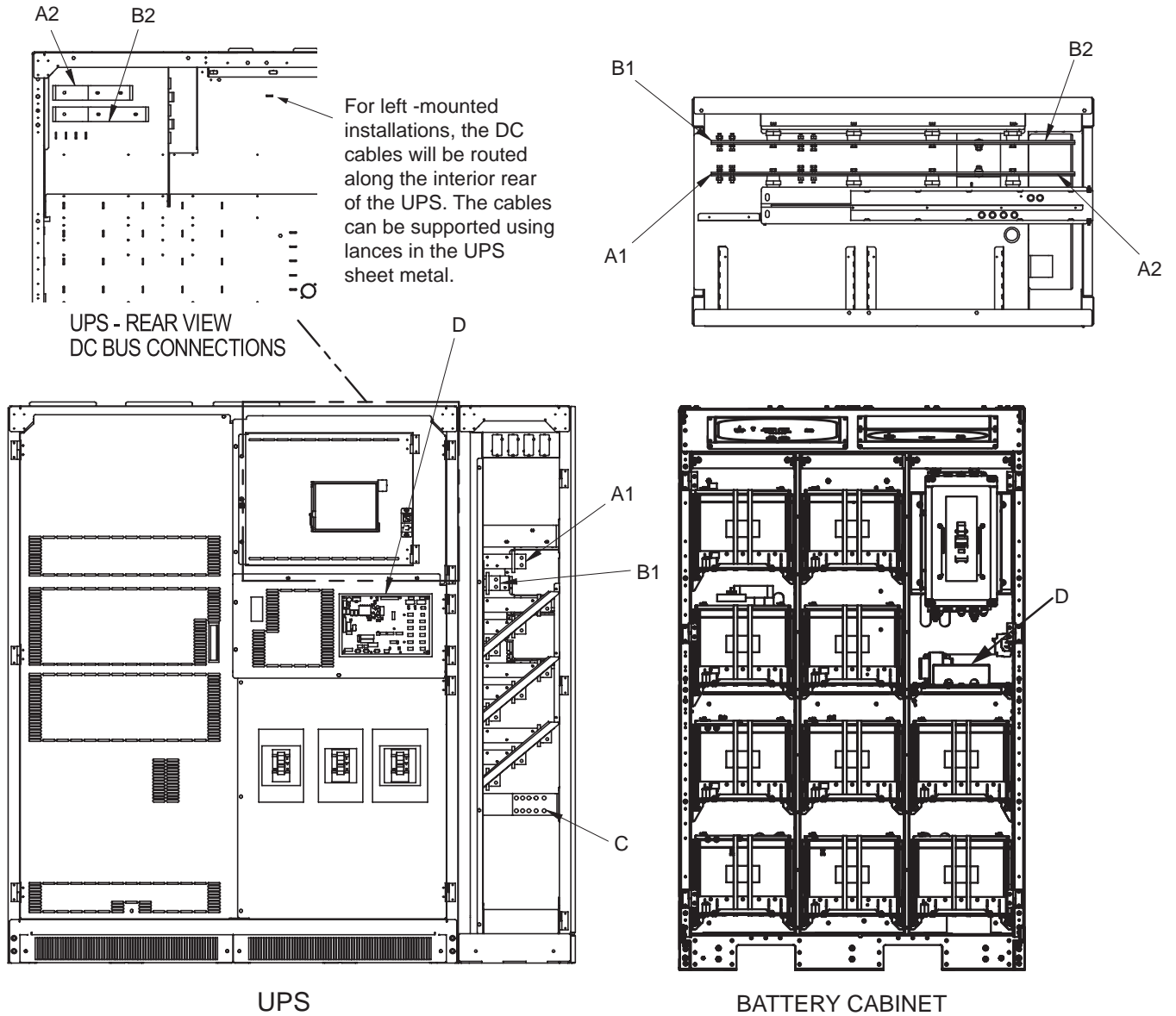


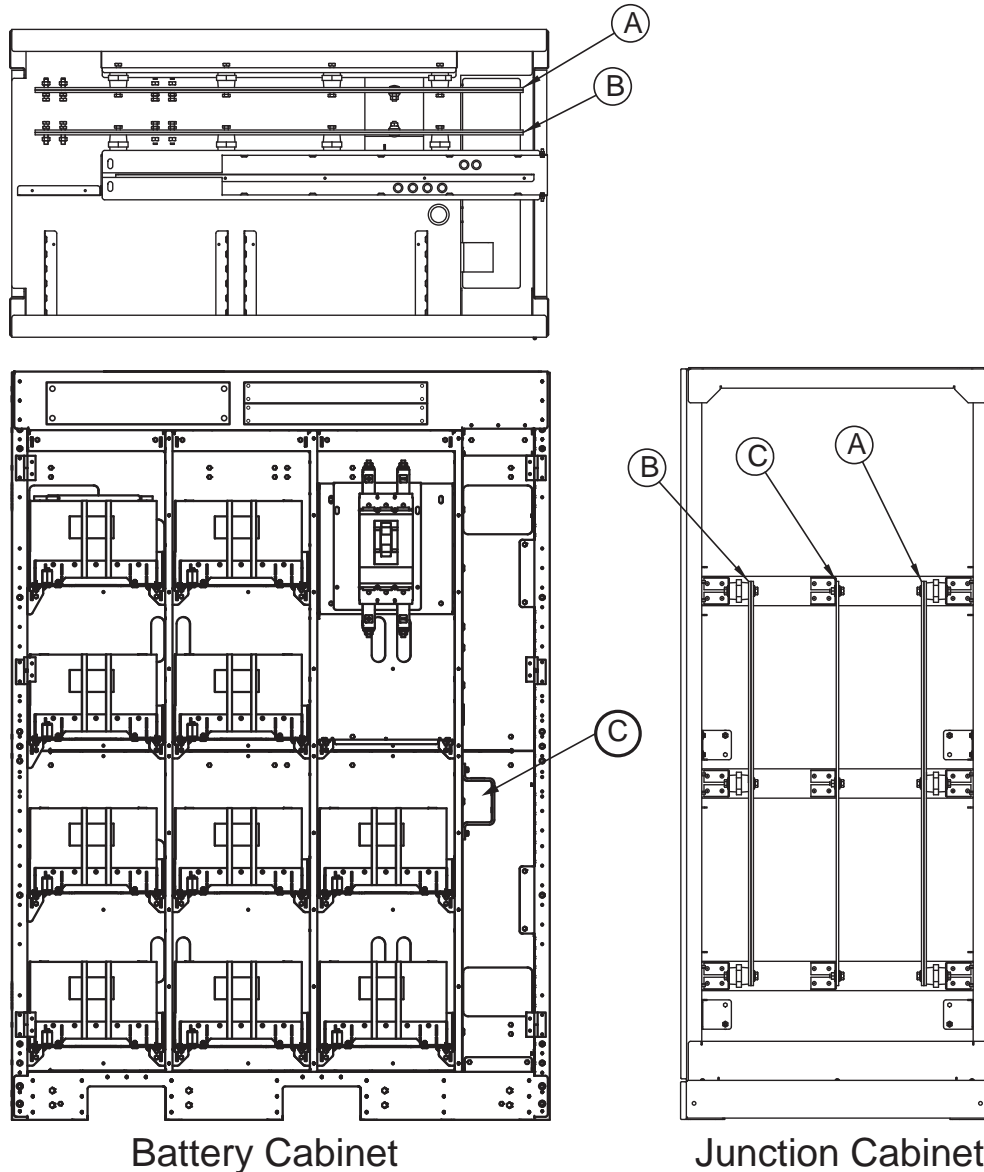
Table 3 Top-terminal battery cabinet interconnection wiring to 250-400kVA UPS

Run	From	To	Conductors
A1	UPS - DC+ Busbar	Battery Cabinet - DC+ Busbar	Positive Power - RH Mount/Stand Alone
B1	UPS - DC- Busbar	Battery Cabinet - DC- Busbar	Negative Power - RH Mount/Stand Alone
A2	UPS - DC+ Busbar	Battery Cabinet - DC+ Busbar	Positive Power - Left Mount
B2	UPS - DC- Busbar	Battery Cabinet - DC- Busbar	Negative Power - Left Mount
C *	UPS - Ground	Battery Cabinet - Ground	Ground
D	UPS - External Interface Board (EIB)	Battery Cabinet - Battery Interface Board (BIB)	CAN Control Cables

\* This is used only for detached cabinets. If the cabinets are attached, use the grounding shown in Figure 34.



**Figure 36** Liebert top-terminal, standard width battery cabinet interconnect wiring to Liebert stand-alone junction cabinet



**Table 4** Liebert top-terminal, standard width battery cabinet interconnect wiring to Liebert junction cabinet

Run	From	To	Conductors
A	Battery Cabinet Negative Bus	Junction Negative Bus	Negative DC Power
B	Battery Cabinet Positive Bus	Junction Positive Bus	Positive DC Power
C	Battery Cabinet Ground	Junction Ground	Ground

Figure 37 Terminal details Liebert NXL™ 250kVA - 400kVA to front-terminal battery point-to-point wiring

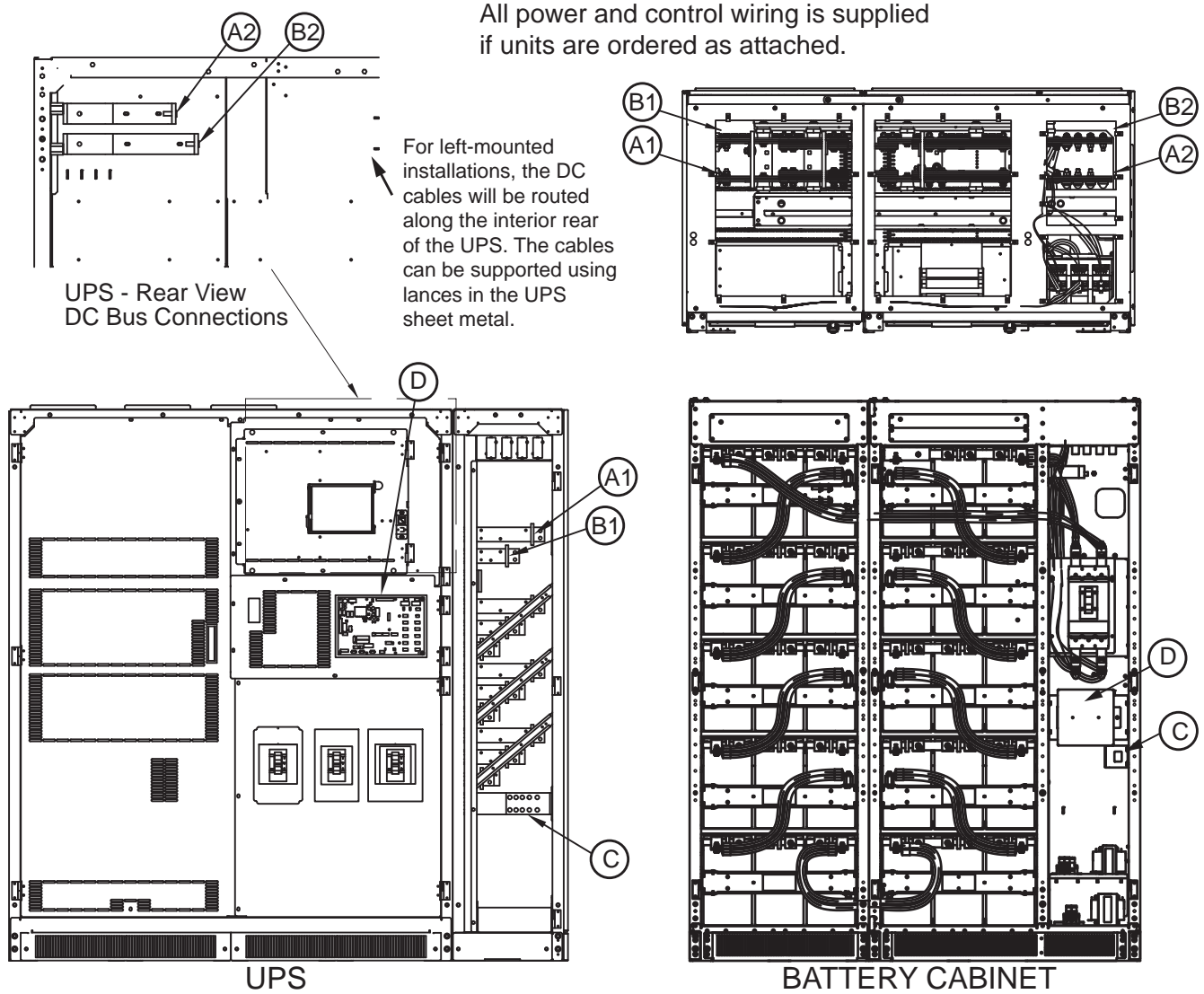
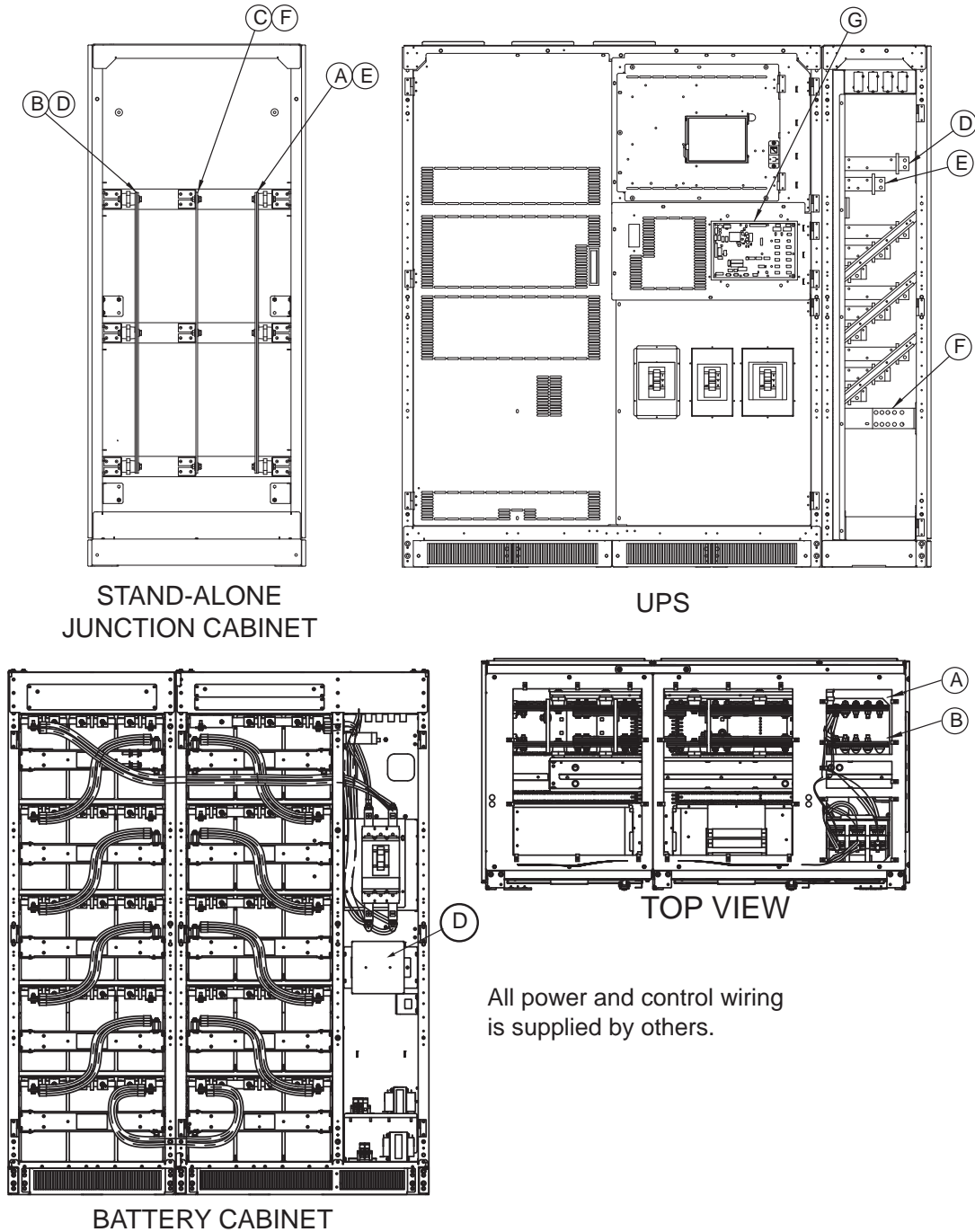


Table 5 Terminal details Liebert UPS 250kVA - 400kVA to front-terminal battery point-to-point interconnect wiring

Run	From	To	Conductors
A1	UPS DC Positive Busbar	Battery Cabinet Positive Bus	Positive DC Power RH Mount /Stand Alone
B1	UPS DC Negative Busbar	Battery Cabinet Negative Bus	Negative DC Power RH Mount / Stand-Alone
A2	UPS DC Positive Busbar	Battery Cabinet Positive Bus	Positive DC Power Left Mount
B2	UPS DC Negative Busbar	Battery Cabinet Negative Bus	Negative DC Power Left Mount
C*	UPS Ground	Battery Cabinet Ground	Ground
D	UPS External Interface Board (EIB)	Battery Cabinet Battery Interface Board (BIB)	CAN Control Cables

\* For detached units only

**Figure 38** Terminal details Liebert NXL™ 250-400kVA front-terminal battery and stand-alone junction cabinet point-to-point wiring



**Table 6** Terminal details Liebert NXL 250-400kVA front-terminal battery and stand-alone junction cabinet point-to-point interconnect wiring

Run	From	To	Conductors
A	Battery Cabinet Negative Bus	Junction Negative Bus	Negative DC Power
B	Battery Cabinet Positive Bus	Junction Positive Bus	Positive DC Power
C	Battery Cabinet Ground	Junction Ground	Ground
D	Junction Positive Bus	UPS Cabinet Positive Bus	Positive DC Power
E	Junction Negative Bus	UPS Cabinet Negative Bus	Negative DC Power
F	Junction Ground	UPS Cabinet Ground	Ground
G	Battery Cabinet Battery Interface Board (BIB)	UPS External Interface Board (EIB)	CAN Control Cables

Figure 39 Terminal details, Liebert NXL™ 500kVA UPS to top-terminal battery and attached junction cabinet, point-to-point wiring

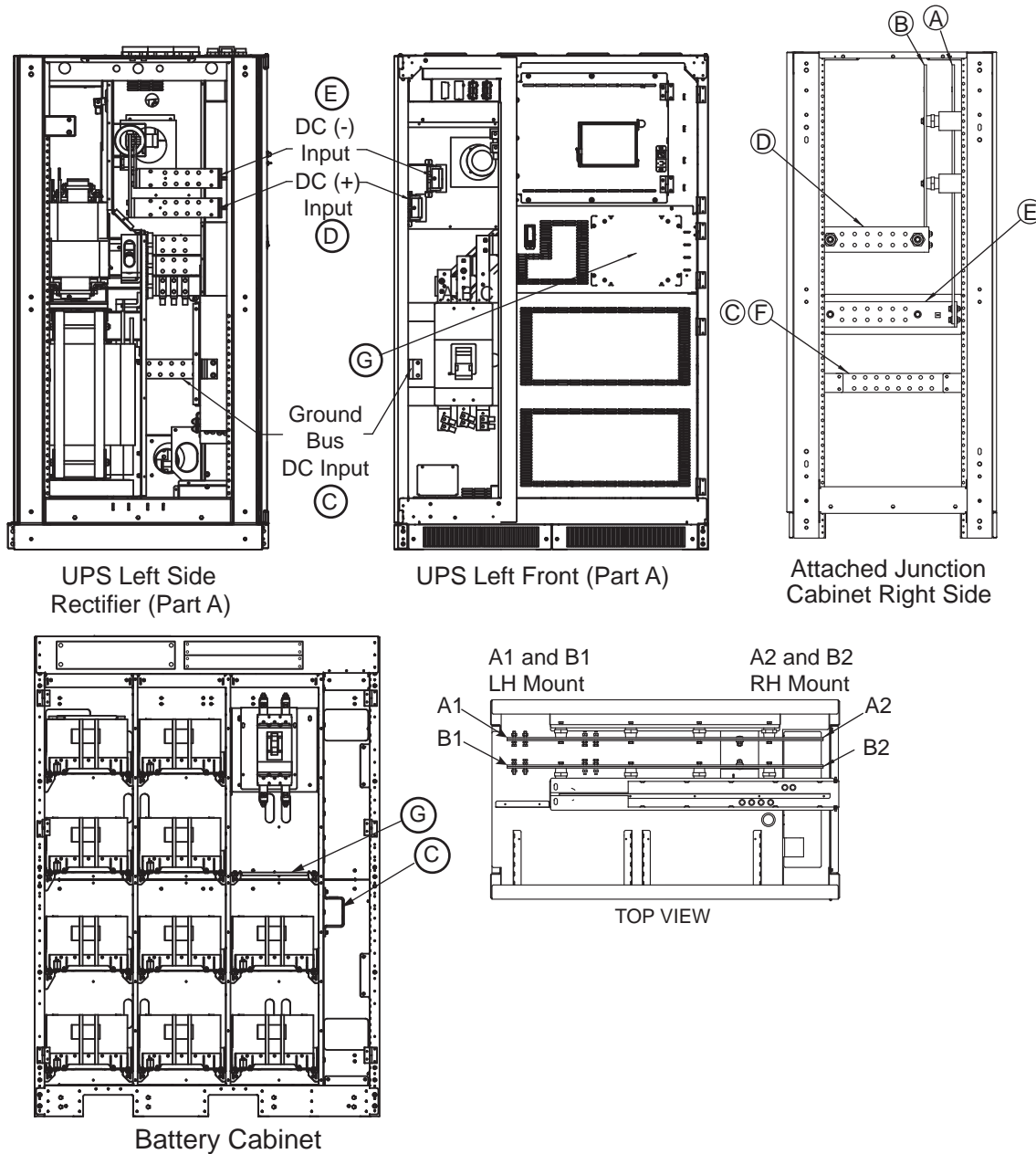
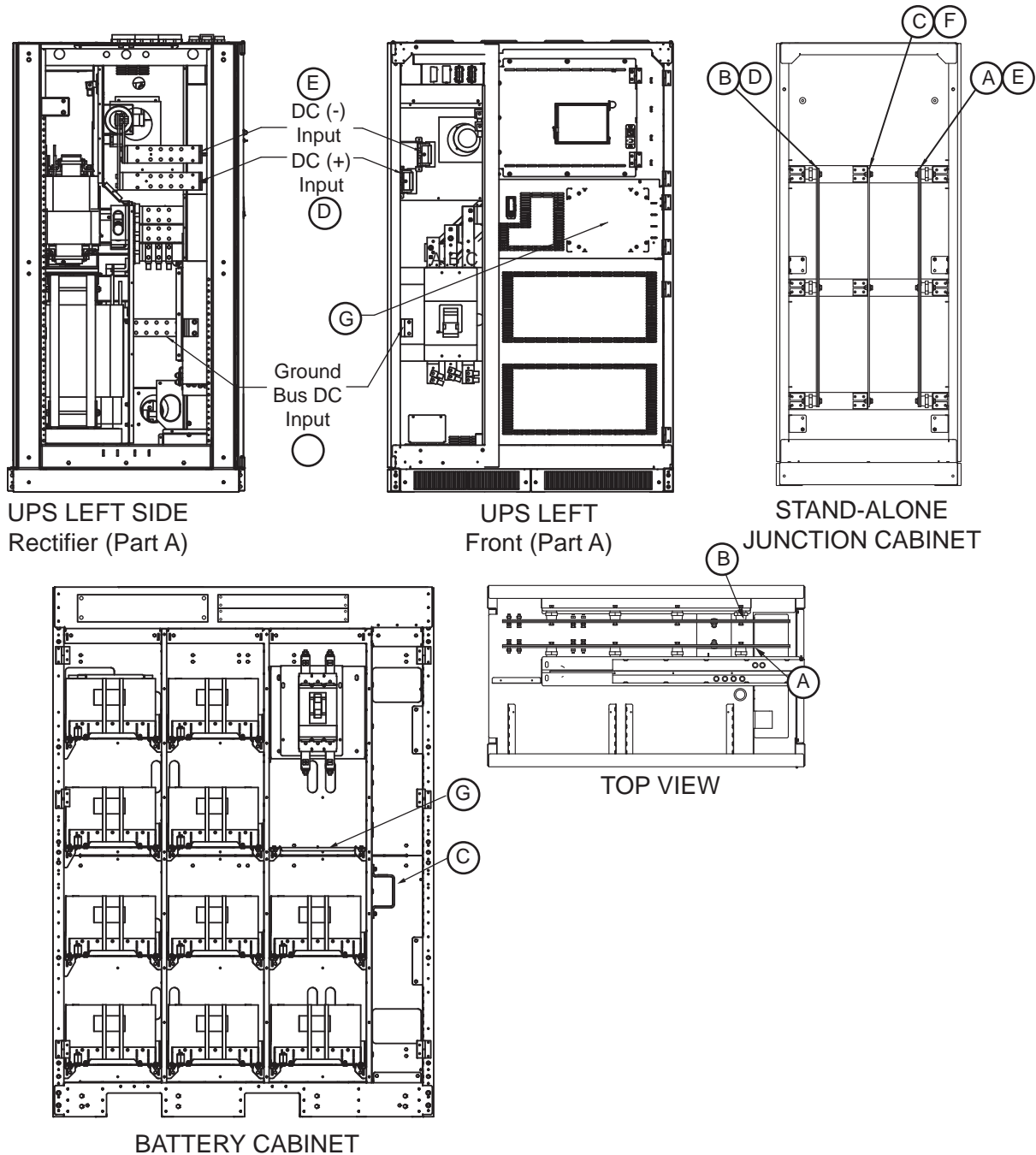


Table 7 Terminal details, Liebert NXL 500kVA UPS to top-terminal battery and attached junction cabinet, point-to-point interconnect wiring

Run	From	To	Conductors
A1	Battery Cabinet Negative Bus	Junction Negative Bus	Negative DC Power (LH Mount)
B1	Battery Cabinet Positive Bus	Junction Positive Bus	Positive DC Power (LH Mount)
A2	Battery Cabinet Negative Bus	Junction Negative Bus	Negative DC Power (RH Mount)
B2	Battery Cabinet Positive Bus	Junction Positive Bus	Positive DC Power (RH Mount)
D	Junction Positive Bus	UPS Cabinet Positive Bus	Positive DC Power
E	Junction Negative Bus	UPS Cabinet Negative Bus	Negative DC Power
F	Junction Ground	UPS Cabinet Ground	Ground
G	Battery Cabinet Battery Interface Board (BIB)	UPS External Interface Board (EIB)	CAN Control Cables

**Figure 40 Terminal details, Liebert NXL™ 500kVA UPS to top-terminal battery and stand-alone junction cabinet, point-to-point wiring**



**Table 8 Terminal details, Liebert NXL 500kVA UPS to top-terminal battery and stand-alone junction cabinet, point-to-point interconnect wiring**

Run	From	To	Conductors
A	Battery Cabinet Negative Bus	Junction Negative Bus	Negative DC Power
B	Battery Cabinet Positive Bus	Junction Positive Bus	Positive DC Power
C	Battery Cabinet Ground	Junction Ground	Ground
D	Junction Positive Bus	UPS Cabinet Positive Bus	Positive DC Power
E	Junction Negative Bus	UPS Cabinet Negative Bus	Negative DC Power
F	Junction Ground	UPS Cabinet Ground	Ground
G	Battery Cabinet Battery Interface Board (BIB)	UPS External Interface Board (EIB)	CAN Control Cables

Figure 41 Terminal details Liebert NXL™ 500kVA to top-terminal battery point-to-point wiring

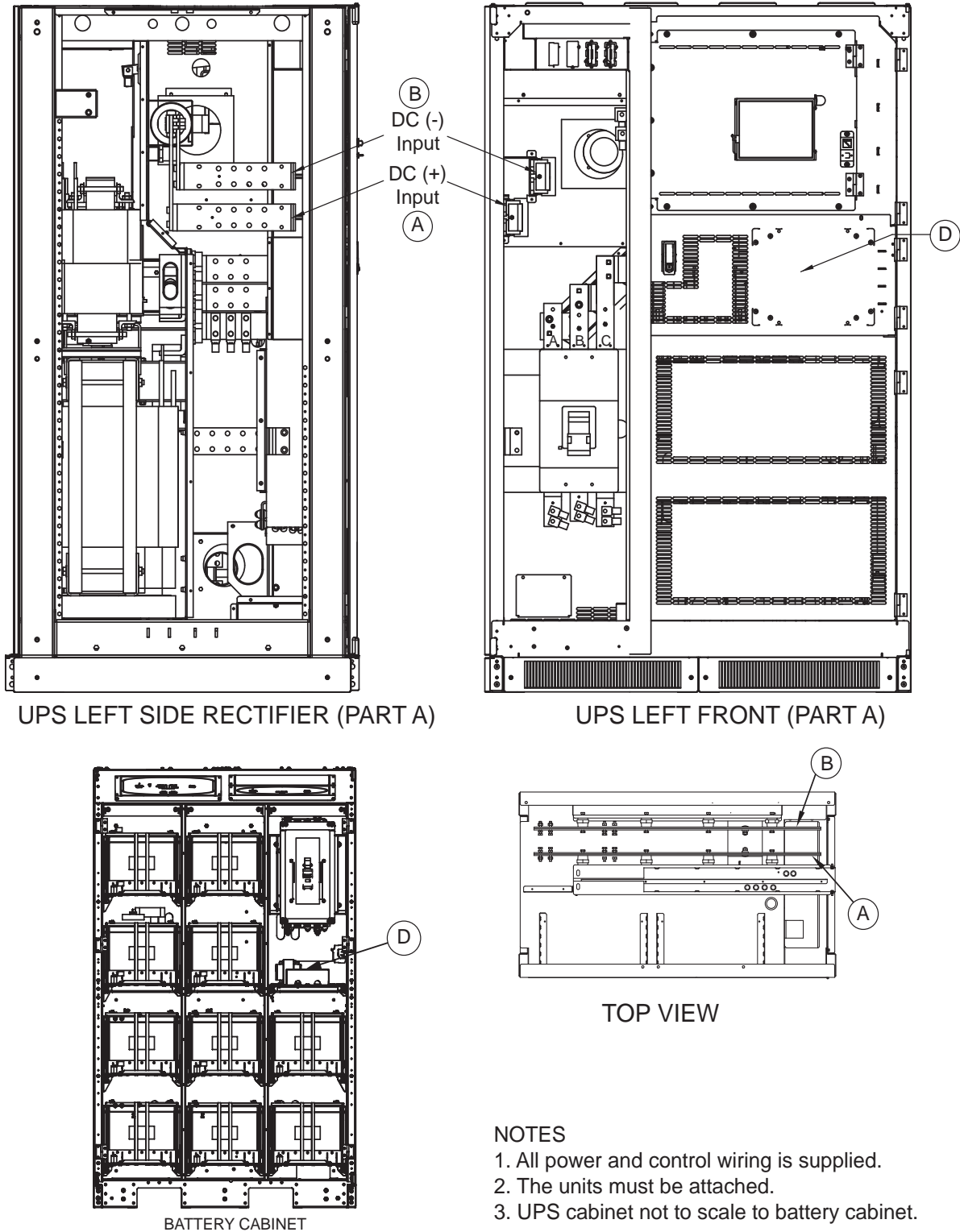


Table 9 Terminal details Liebert NXL 500kVA to top-terminal battery point-to-point interconnect wiring

Run	From	To	Conductors
A	UPS Positive Bus	Battery Cabinet Positive Bus	Positive DC Power
B	UPS Negative Bus	Battery Cabinet Negative Bus	Negative DC Power
D	UPS External Interface Board (EIB)	Battery Cabinet Battery Interface Board (BIB)	CAN Control Cables

Figure 42 Terminal details Liebert NXL™ 500kVA to front-terminal battery point-to-point wiring

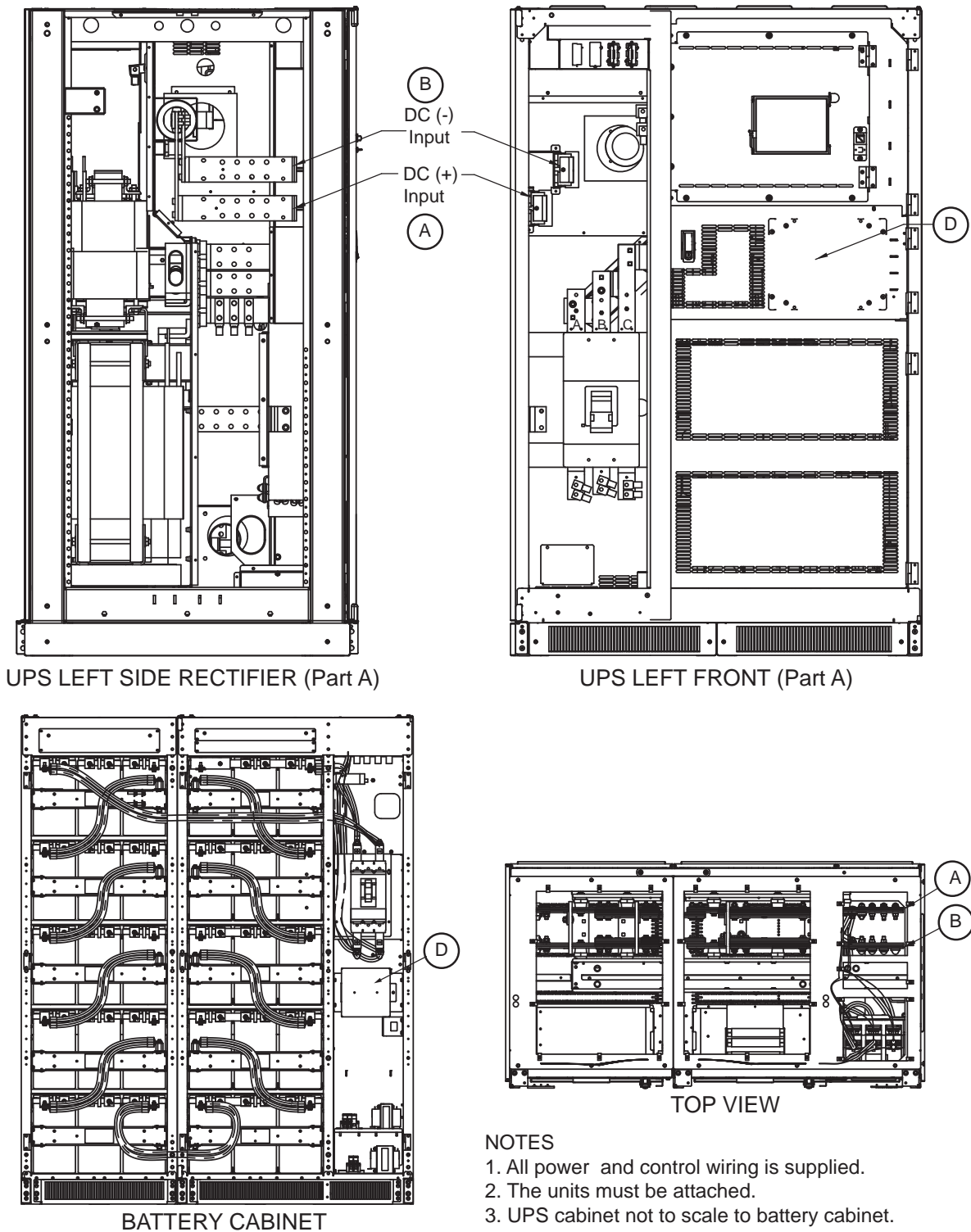
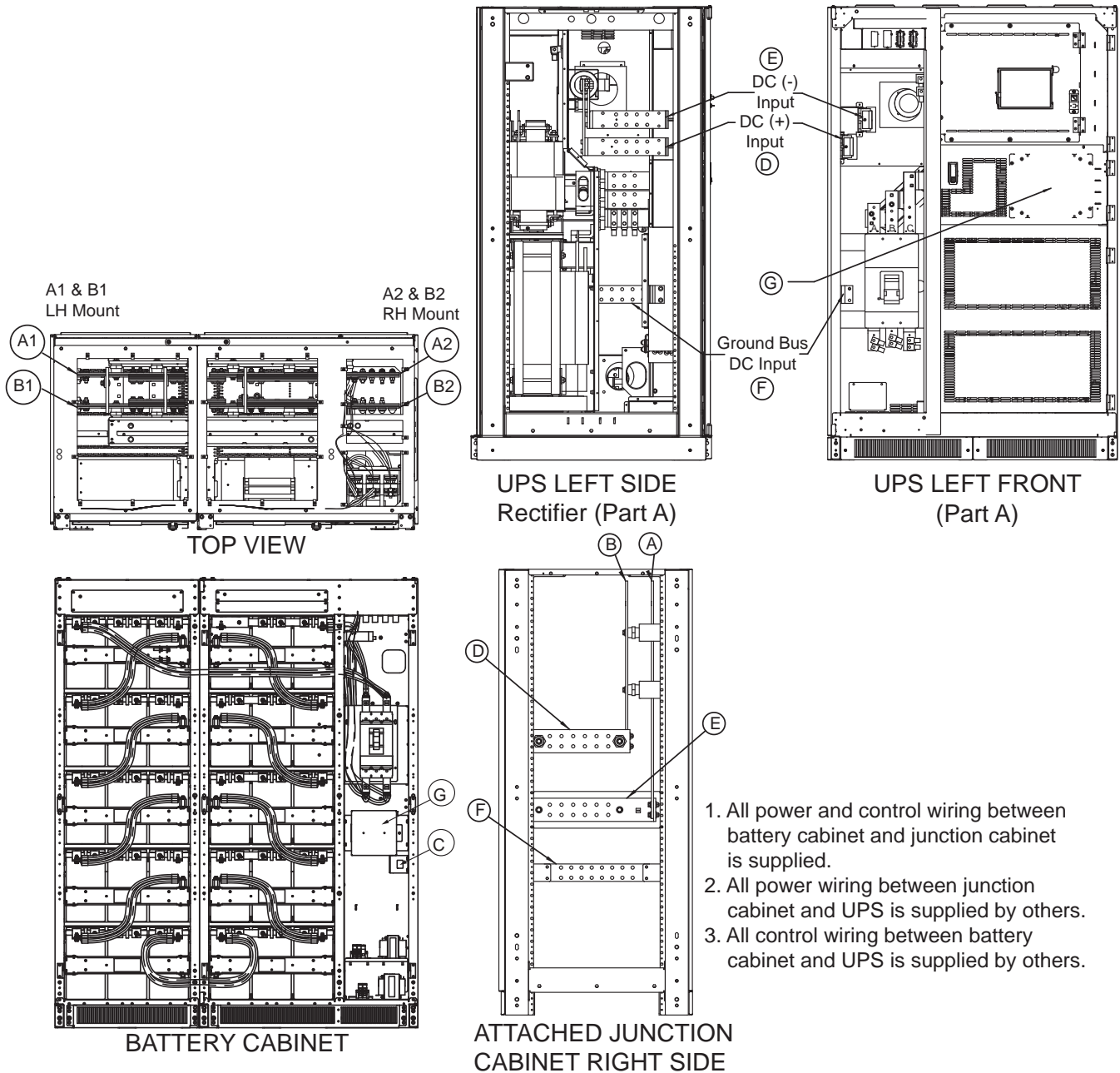


Table 10 Terminal details Liebert NXL 500kVA to front-terminal battery point-to-point interconnect wiring

Run	From	To	Conductor
A	UPS Positive Bus	Battery Cabinet Positive Bus	Positive DC Power
B	UPS Negative Bus	Battery Cabinet Negative Bus	Negative DC Power
D	UPS External Interface Board (EIB)	Battery Cabinet Battery Interface Board (BIB)	CAN Control Cables



**Figure 43** Liebert NXL™ terminal details UPS 625/750kVA to front-terminal battery and attached junction cabinet point-to-point wiring

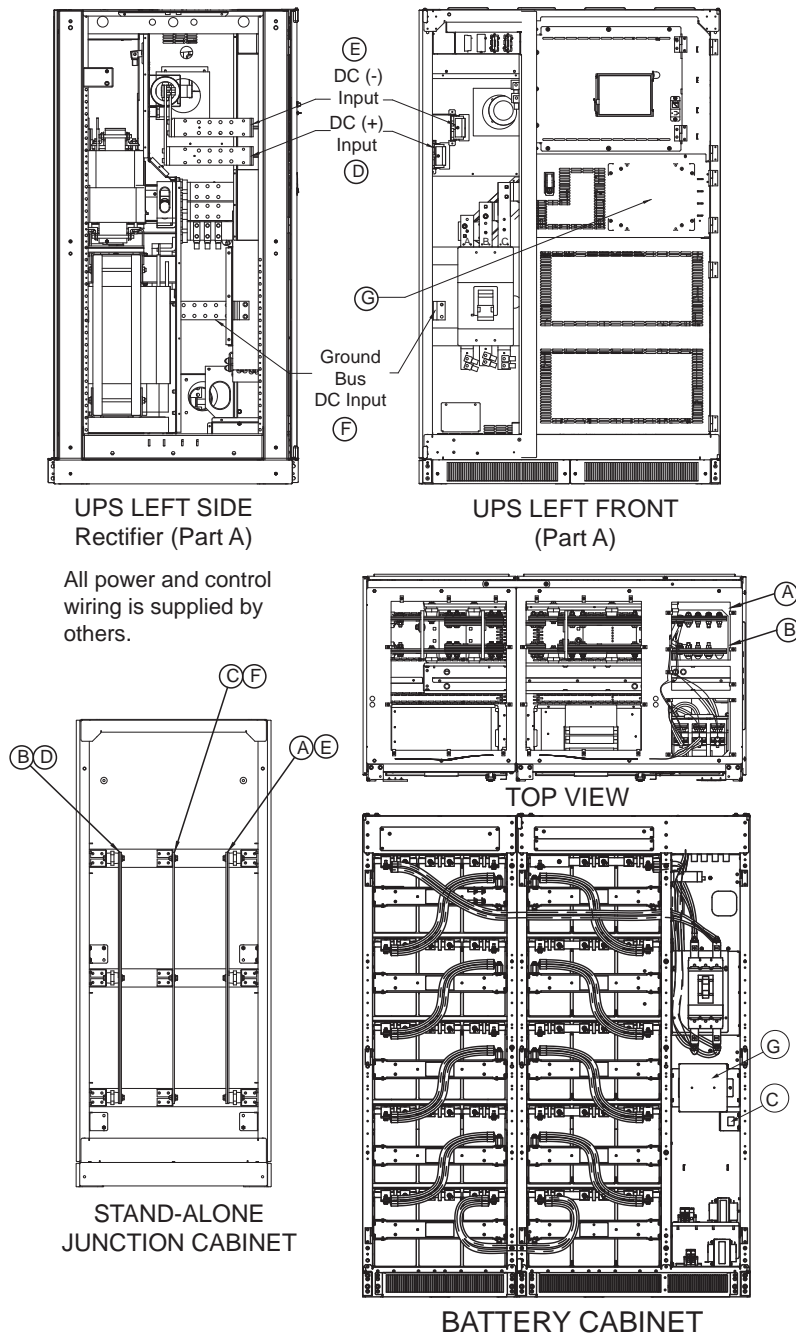


**Table 11** Liebert NXL terminal details UPS 625/750kVA to front-terminal battery and attached junction cabinet point-to-point Interconnect wiring

Run	From	To	Conductors
A1	Battery Cabinet Negative Bus	Junction Negative Bus	Negative DC Power (LH Mount)
B1	Battery Cabinet Positive Bus	Junction Positive Bus	Positive DC Power (LH Mount)
A2	Battery Cabinet Negative Bus	Junction Negative Bus	Negative DC Power (RH Mount)
B2	Battery Cabinet Positive Bus	Junction Positive Bus	Positive DC Power (RH Mount)
D	Junction Positive Bus	UPS Cabinet Positive Bus	Positive DC Power
E	Junction Negative Bus	UPS Cabinet Negative Bus	Negative DC Power
F	Junction Ground	UPS Cabinet Ground	Ground
G	Battery Cabinet Battery Interface Board (BIB)	UPS External Interface Board (EIB)	CAN Control Cables



**Figure 44** Liebert NXL™ terminal details UPS 625/750kVA to front-terminal battery and stand-alone junction cabinet point-to-point wiring



**Table 12** Liebert NXL terminal details UPS 625/750kVA to front-terminal battery and stand-alone junction cabinet point-to-point interconnect wiring

Run	From	To	Conductors
A	Battery Cabinet Negative Bus	Junction Negative Bus	Negative DC Power
B	Battery Cabinet Positive Bus	Junction Positive Bus	Positive DC Power
C	Battery Cabinet Ground	Junction Ground	Ground
D	Junction Positive Bus	UPS Cabinet Positive Bus	Positive DC Power
E	Junction Negative Bus	UPS Cabinet Negative Bus	Negative DC Power
F	Junction Ground	UPS Cabinet Ground	Ground
G	Battery Cabinet Battery Interface Board (BIB)	UPS External Interface Board (EIB)	CAN Control Cables

Figure 45 Terminal details, Liebert NXL™ 625/750kVA UPS to top-terminal battery and attached junction cabinet, point-to-point wiring

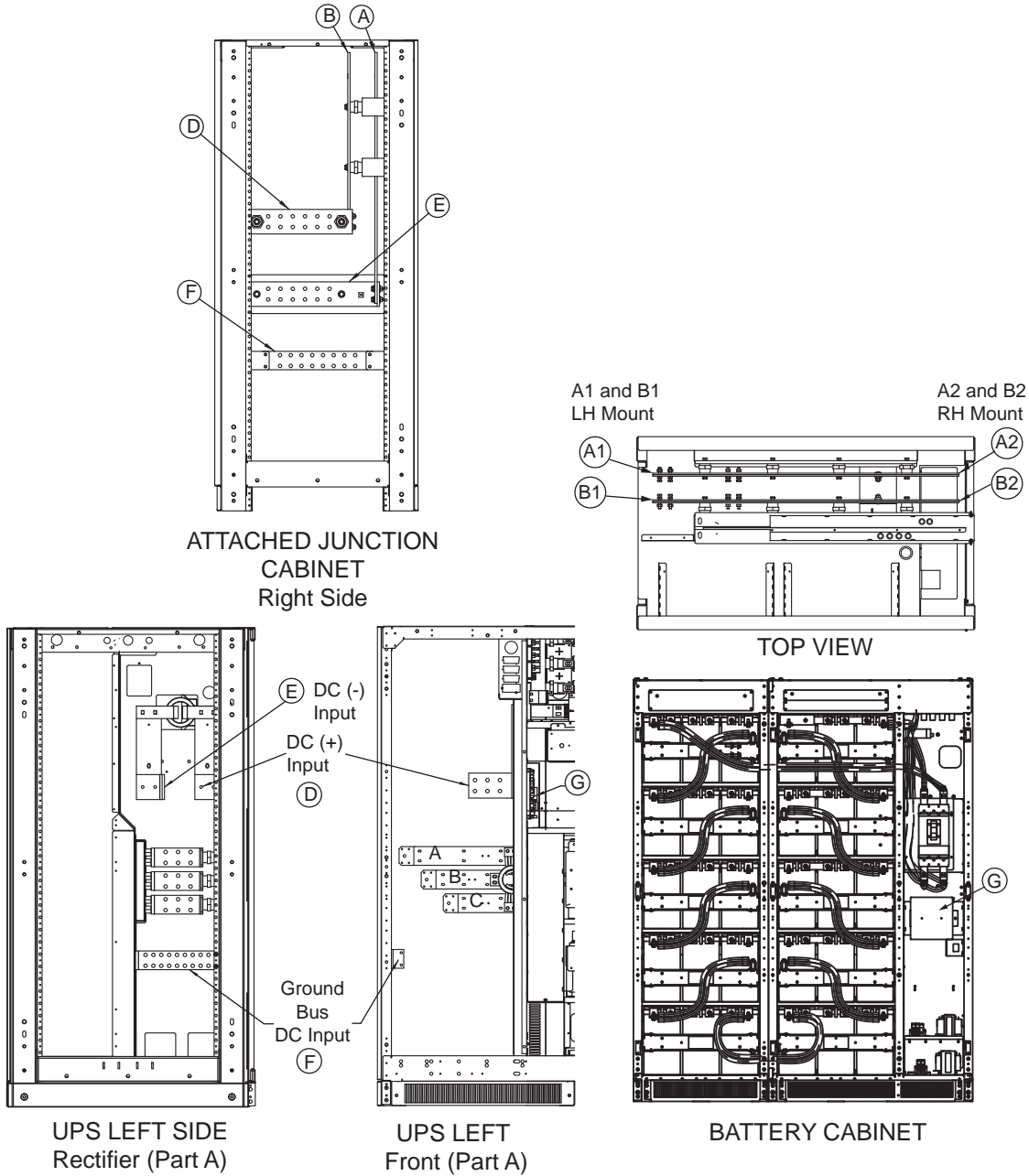
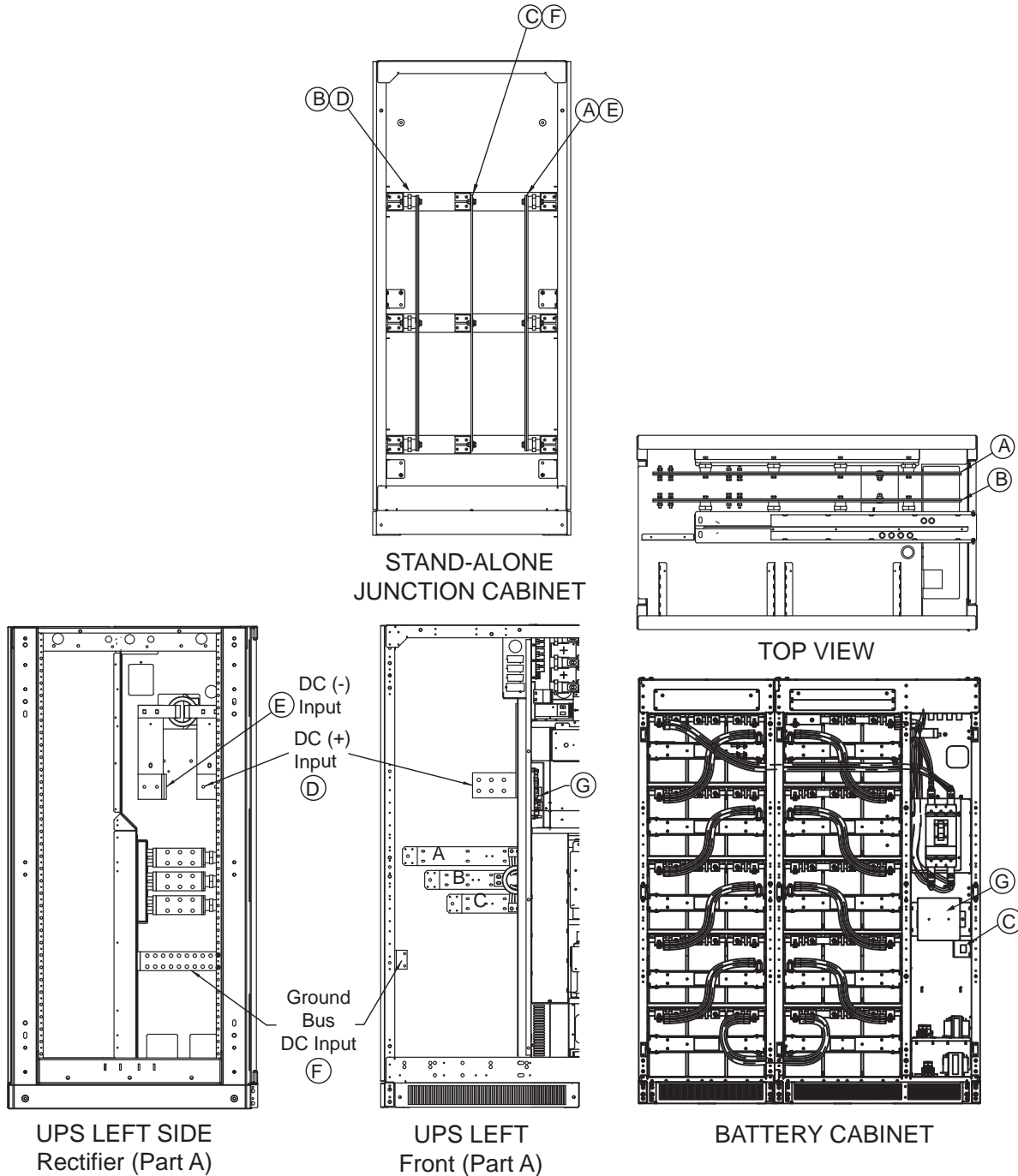


Table 13 Terminal details, Liebert NXL 625/750kVA UPS to top-terminal battery and attached junction cabinet, point-to-point wiring

Run	From	To	Conductor
A1	Battery Cabinet Negative Bus	Junction Negative Bus	Negative DC Power (LH Mount)
B1	Battery Cabinet Positive Bus	Junction Positive Bus	Positive DC Power (LH Mount)
A2	Battery Cabinet Negative Bus	Junction Negative Bus	Negative DC Power (RH Mount)
B2	Battery Cabinet Positive Bus	Junction Positive Bus	Positive DC Power (RH Mount)
D	Junction Positive Bus	UPS Cabinet Positive Bus	Positive DC Power
E	Junction Negative Bus	UPS Cabinet Negative Bus	Negative DC Power
F	Junction Ground	UPS Cabinet Ground	Ground
G	Battery Cabinet, Battery Interface Board (BIB)	UPS External Interface Board (EIB)	CAN Control Cables

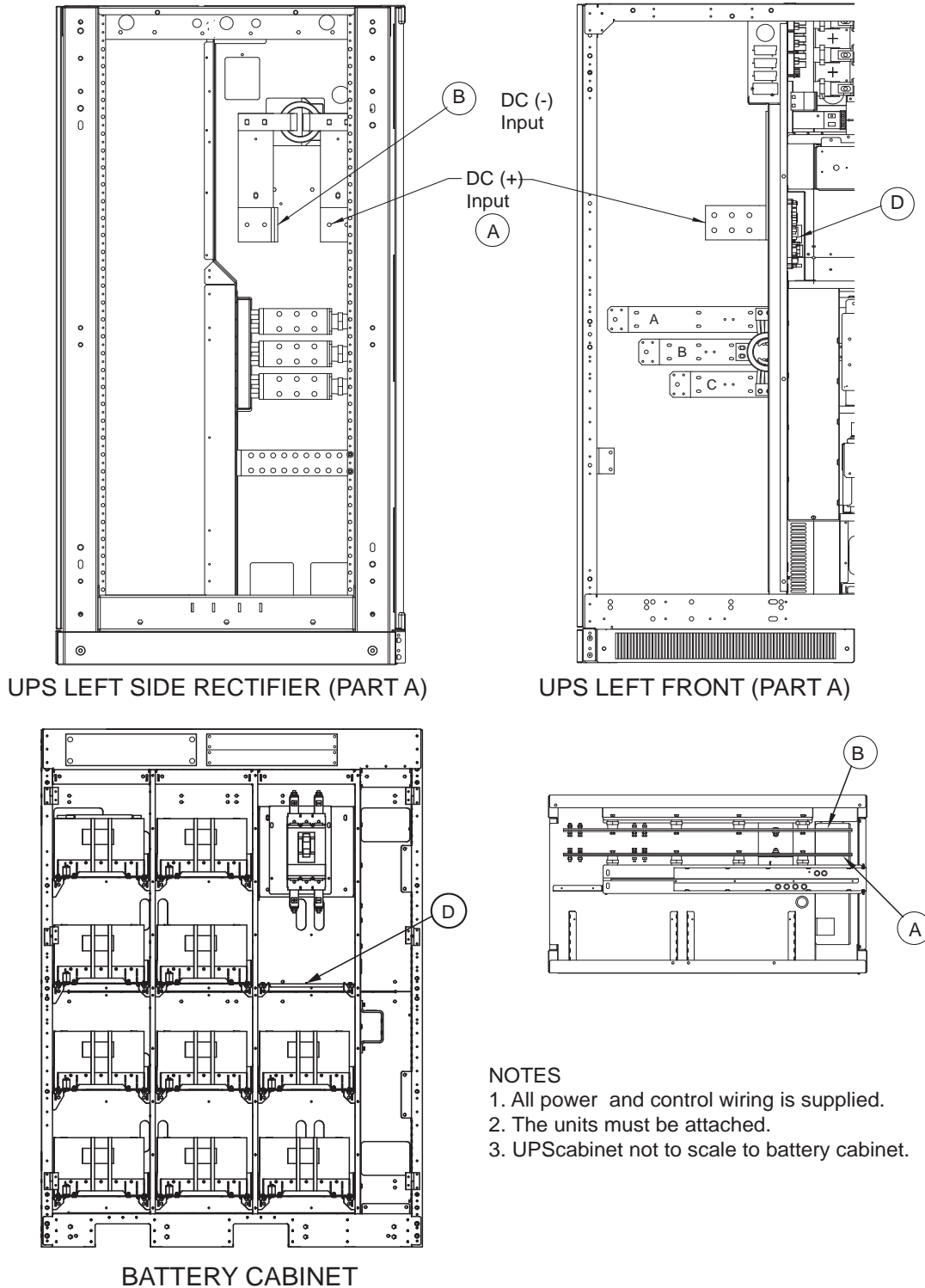
**Figure 46** Terminal details, Liebert NXL™ 625/750kVA UPS to top-terminal battery and stand-alone junction cabinet, point-to-point wiring



**Table 14** Terminal details, Liebert NXL 625/750kVA UPS to top-terminal battery and stand-alone junction cabinet, point-to-point interconnect wiring

Run	From	To	Conductors
A	Battery Cabinet Negative Bus	Junction Negative Bus	Negative DC Power
B	Battery Cabinet Positive Bus	Junction Positive Bus	Positive DC Power
C	Battery Cabinet Ground	Junction Ground	Ground
D	Junction Positive Bus	UPS Cabinet Positive Bus	Positive DC Power
E	Junction Negative Bus	UPS Cabinet Negative Bus	Negative DC Power
F	Junction Ground	UPS Cabinet Ground	Ground
G	Battery Cabinet Battery Interface Board (BIB)	UPS External Interface Board (EIB)	CAN Control Cables

Figure 47 Terminal details Liebert NXL™ UPS 625/750kVA to top-terminal battery point-to-point wiring



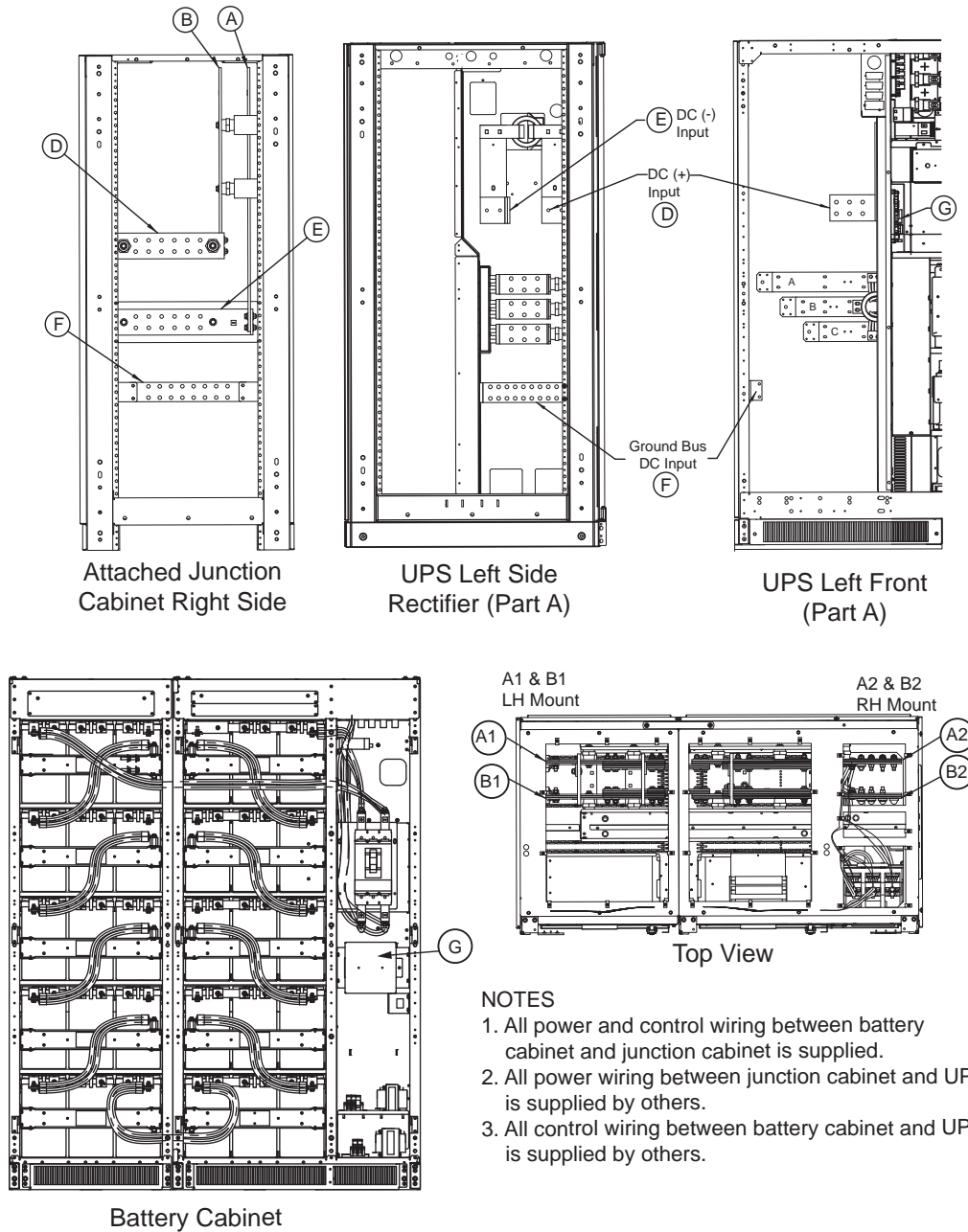
NOTES

1. All power and control wiring is supplied.
2. The units must be attached.
3. UPS cabinet not to scale to battery cabinet.

Table 15 Terminal details Liebert NXL UPS 625/750kVA to battery point-to-point interconnect wiring

Run	From	To	Conductor
A	UPS Positive Bus	Battery Cabinet Positive Bus	Positive DC Power
B	UPS Negative Bus	Battery Cabinet Negative Bus	Negative DC Power
D	UPS External Interface Board (EIB)	Battery Cabinet Battery Interface Board (BIB)	CAN Control Cables

**Figure 48 Terminal details 625/750kVA UPS to front-terminal battery and attached junction cabinet point-to-point wiring**



**Table 16 Terminal details 625/750kVA UPS to front-terminal battery and attached junction cabinet point-to-point interconnect wiring**

Run	From	To	Conductor
A1	Battery Cabinet Negative Bus	Junction Negative Bus	Negative DC Power (LH Mount)
B1	Battery Cabinet Positive Bus	Junction Positive Bus	Positive DC Power (LH Mount)
A2	Battery Cabinet Negative Bus	Junction Negative Bus	Negative DC Power (RH Mount)
B2	Battery Cabinet Positive Bus	Junction Positive Bus	Positive DC Power (RH Mount)
D	Junction Positive Bus	UPS Cabinet Positive Bus	Positive DC Power
E	Junction Negative Bus	UPS Cabinet Negative Bus	Negative DC Power
F	Junction Ground	UPS Cabinet Ground	Ground
G	Battery Cabinet Battery Interface Board (BIB)	UPS External Interface Board (EIB)	CAN Control Cables

Figure 49 Terminal details 625/750kVA to front-terminal battery and stand-alone junction cabinet point-to-point wiring

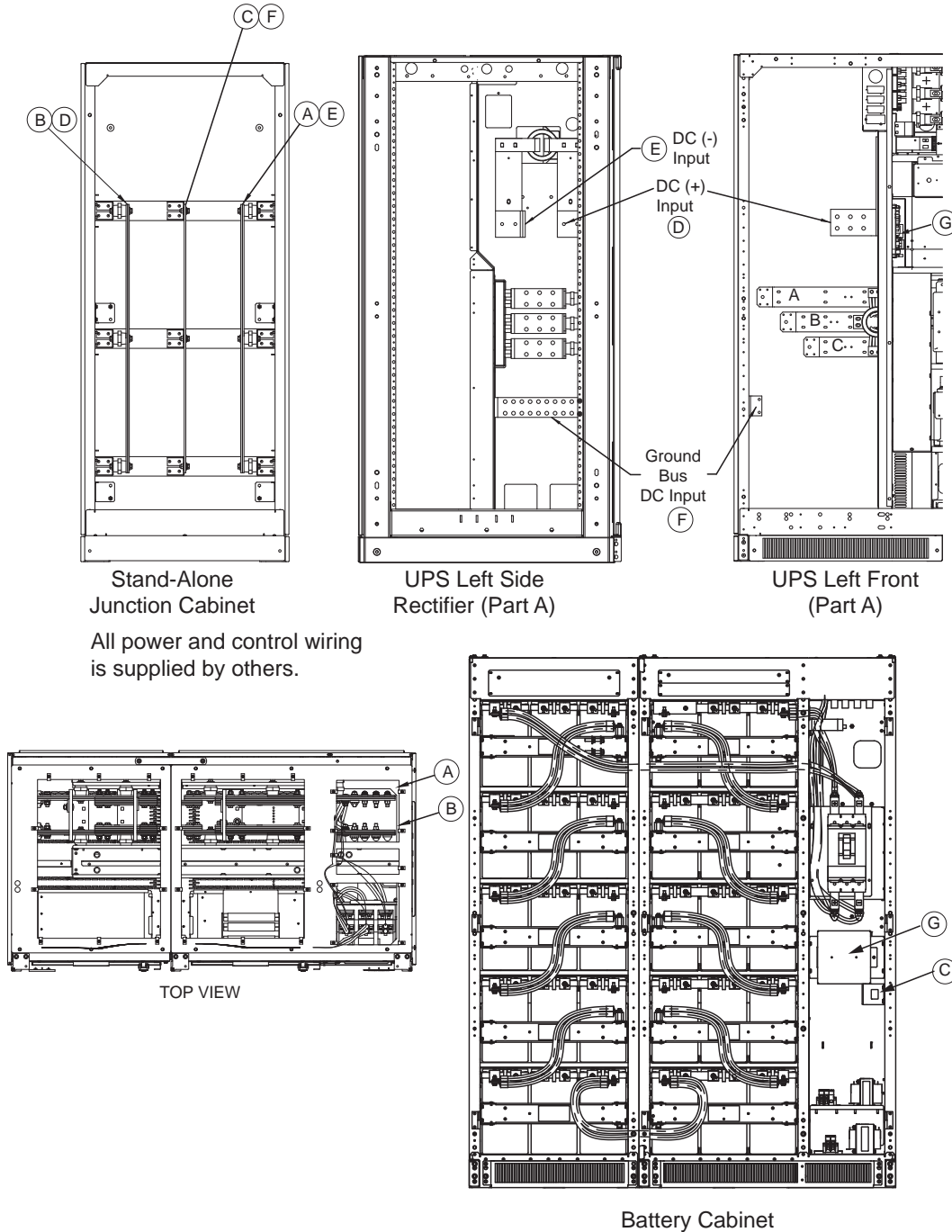


Table 17 Terminal details 625/750kVA to front-terminal battery and stand-alone junction cabinet point-to-point interconnect wiring

Run	From	To	Conductor
A	Battery Cabinet Negative Bus	Junction Negative Bus	Negative DC Power
B	Battery Cabinet Positive Bus	Junction Positive Bus	Positive DC Power
C	Battery Cabinet Ground	Junction Ground	Ground
D	Junction Positive Bus	UPS Cabinet Positive Bus	Positive DC Power
E	Junction Negative Bus	UPS Cabinet Negative Bus	Negative DC Power
F	Junction Ground	UPS Cabinet Ground	Ground
G	Battery Cabinet Battery Interface Board (BIB)	UPS External Interface Board (EIB)	CAN Control Cables

Figure 50 Typical Alber® battery monitoring connections

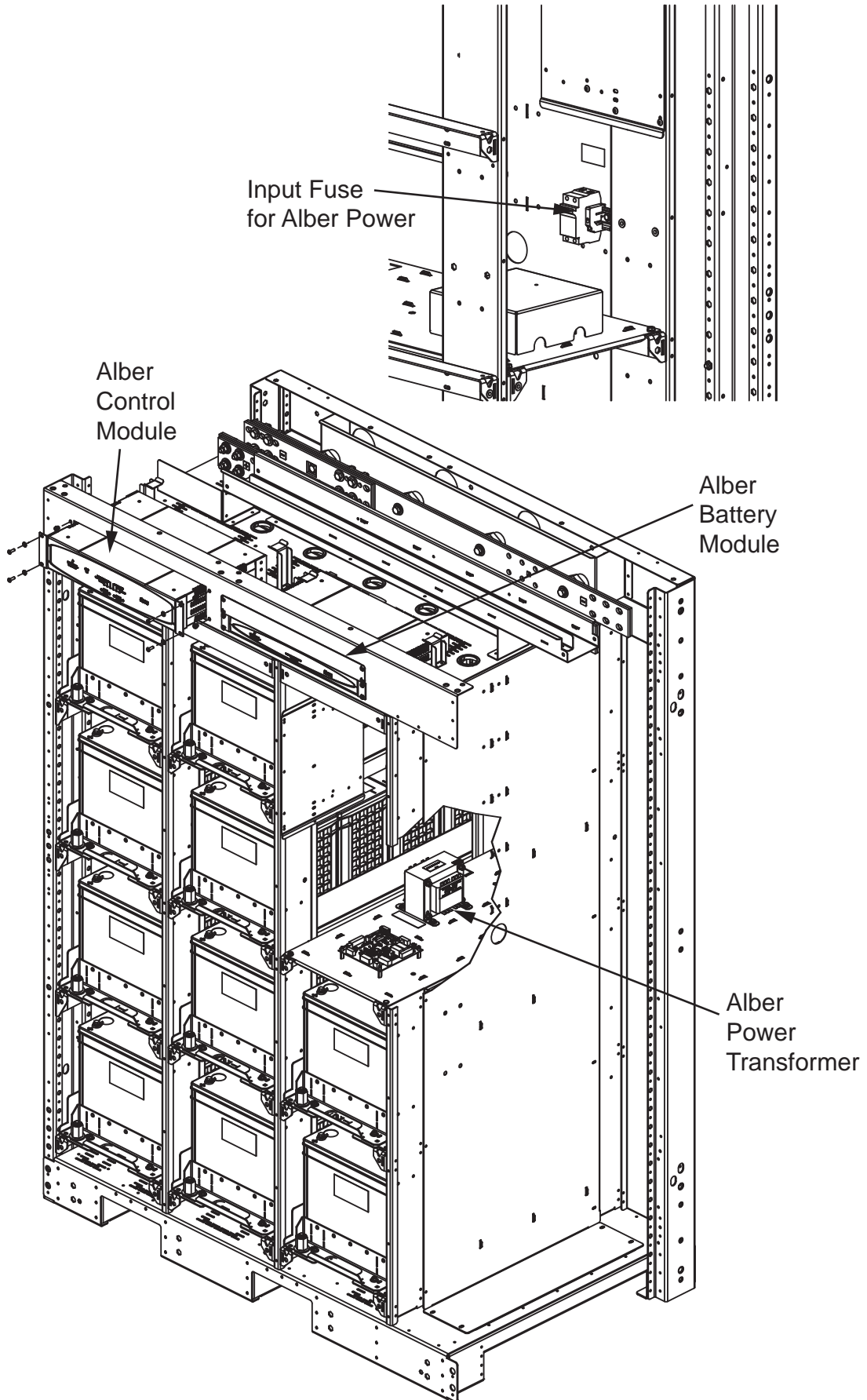
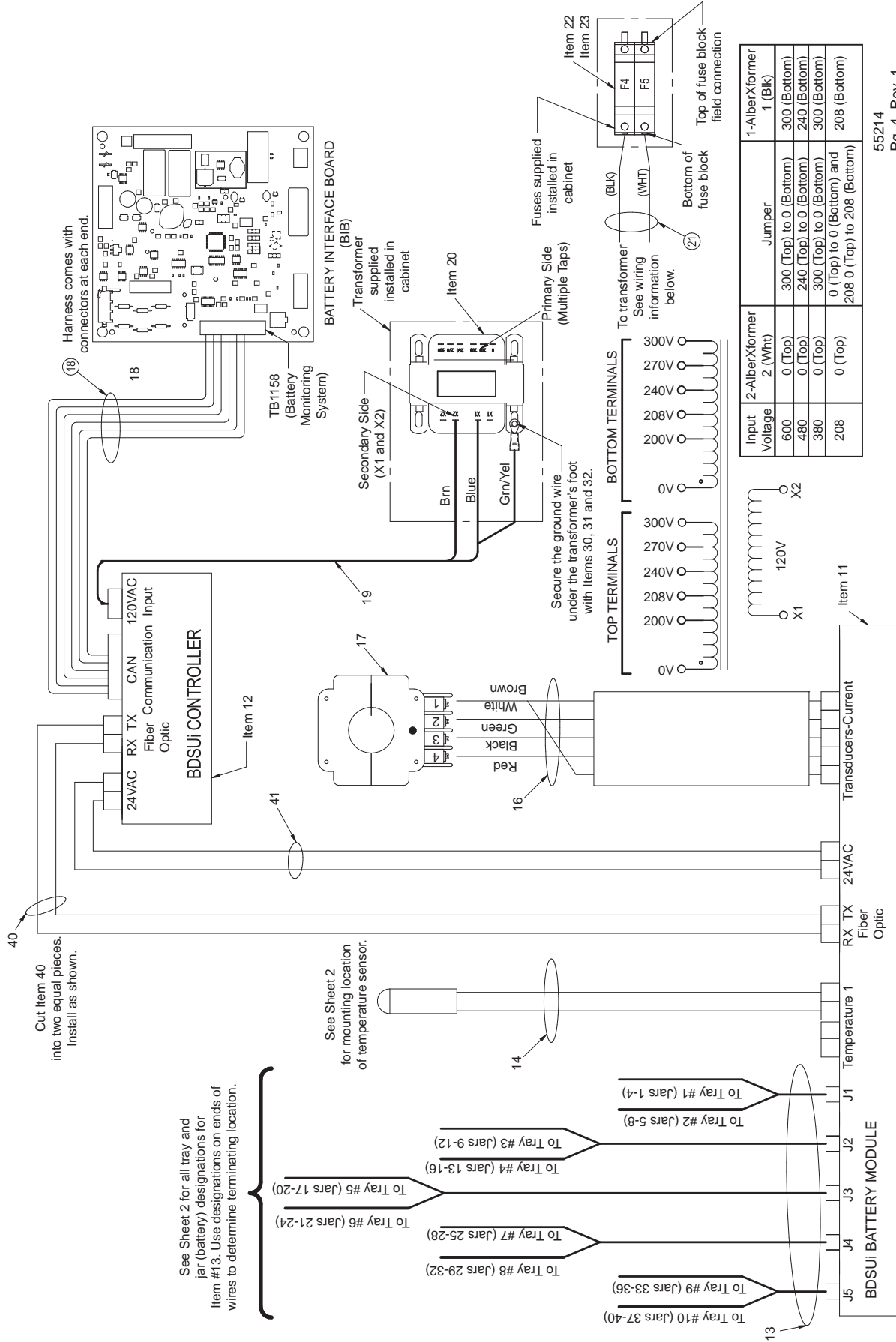




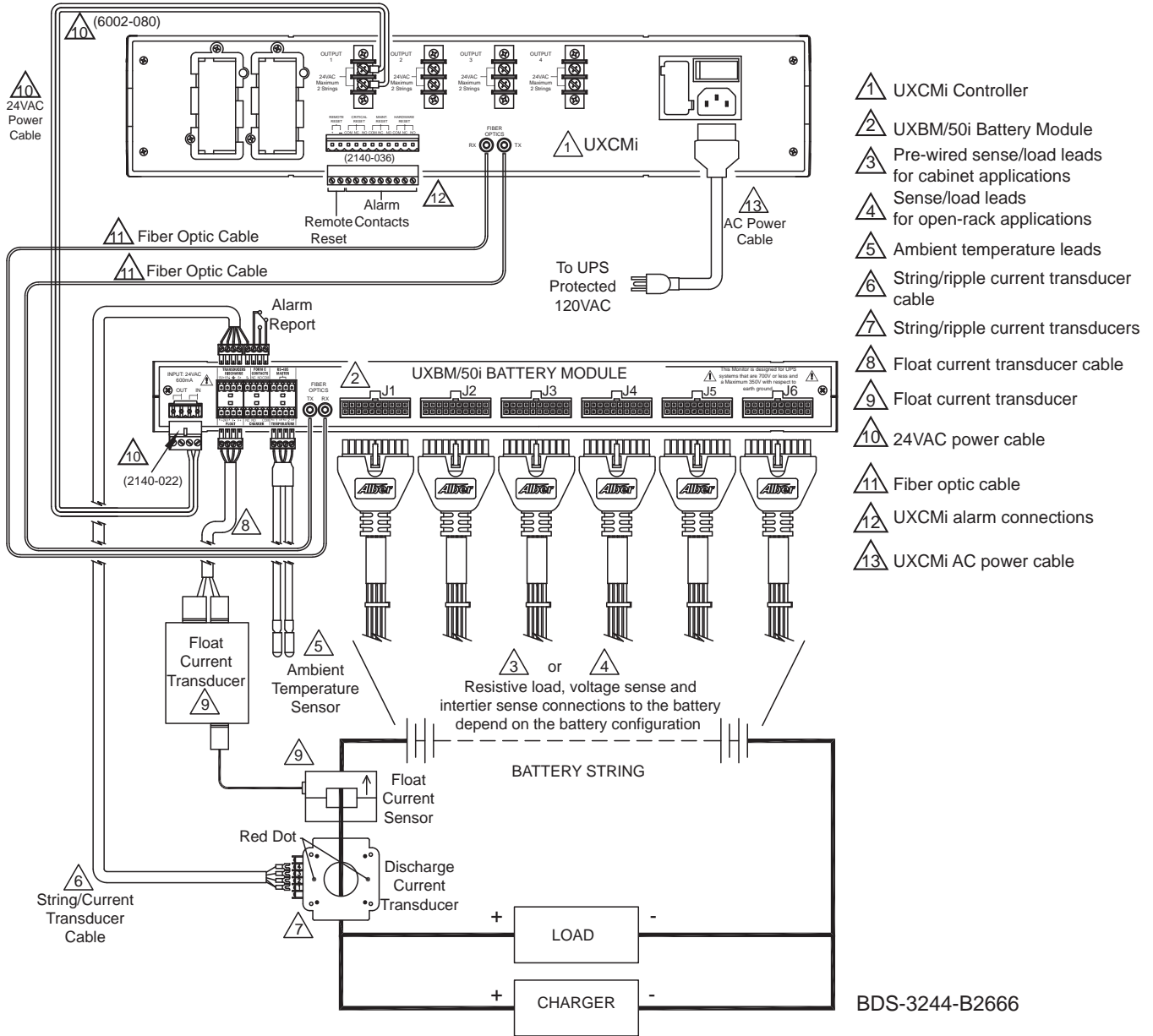
Figure 51 Alber® battery monitoring wiring to multiple battery cabinets



55214  
Pg. 4, Rev. 1



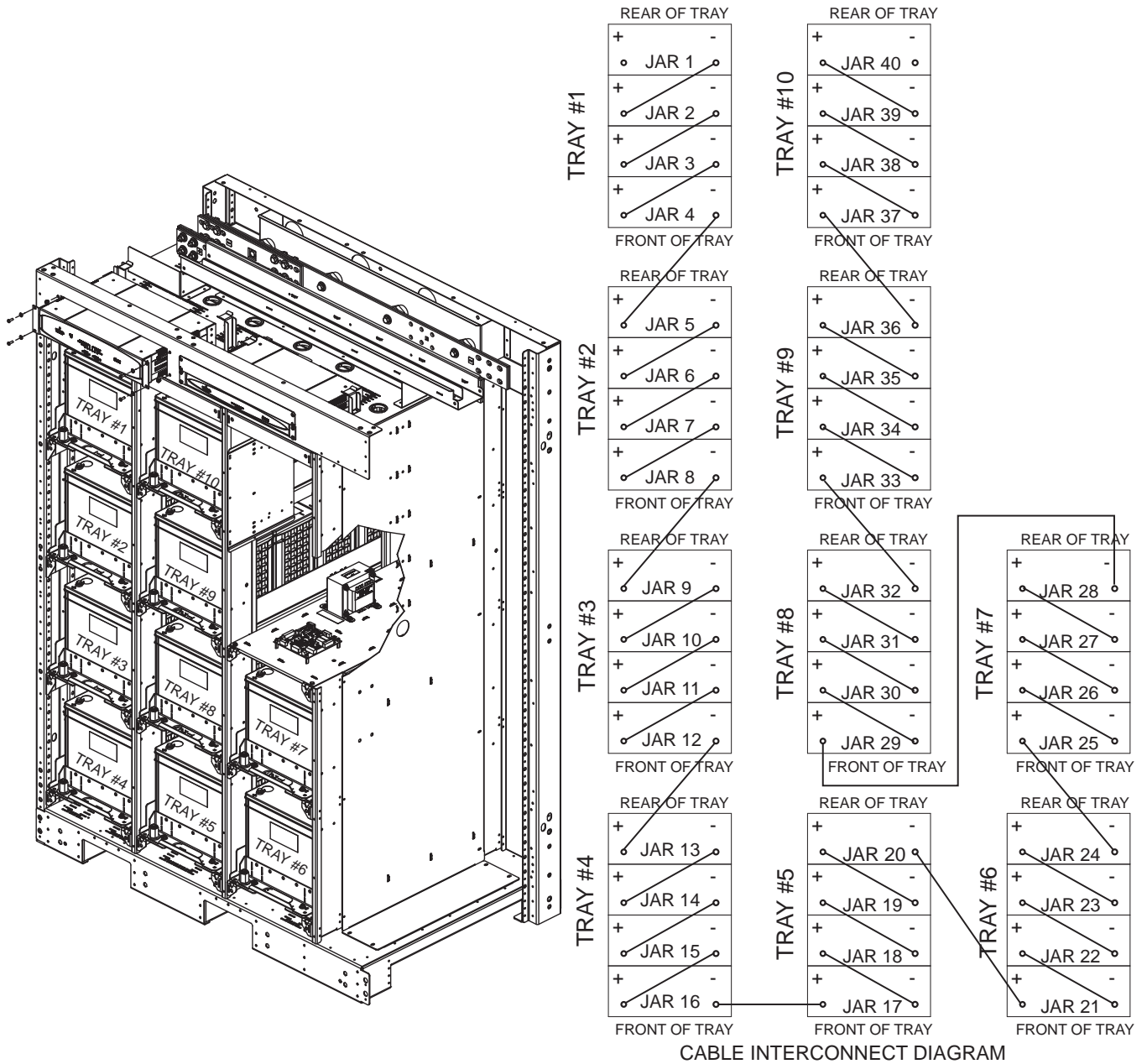
**Figure 52 Alber® battery monitoring assembly diagram**



**Table 18 Alber battery monitoring assembly connections**

Input Voltage	Alber Transformer-2: Wht	Jumper	Alber Transformer-1: Blk	F4-F5 Fuse Rating
600	0 (Top)	300 (Top) to 0 (Bottom)	300 (Bottom)	1.25 A, 600VAC
480	0 (Top)	240 (Top) to 0 (Bottom)	240 (Bottom)	1.5 A, 600VAC
380	0 (Top)	300 (Top) to 208 (Bottom)	300 (Bottom)	2.0 A, 600VAC
208	0 (Top)	0 (Top) to 0 (Bottom) and 208 (Top) to 208 (Bottom)	208 (Top)	3.5A, 600VAC

Figure 53 Top-terminal battery configuration



**Figure 54** Front-terminal battery configuration

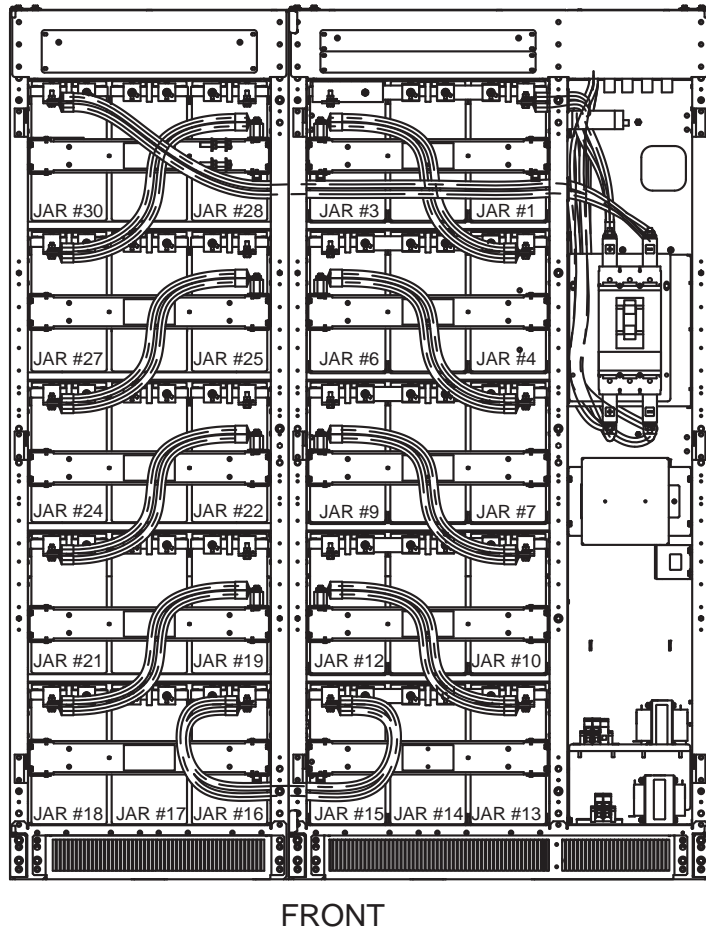
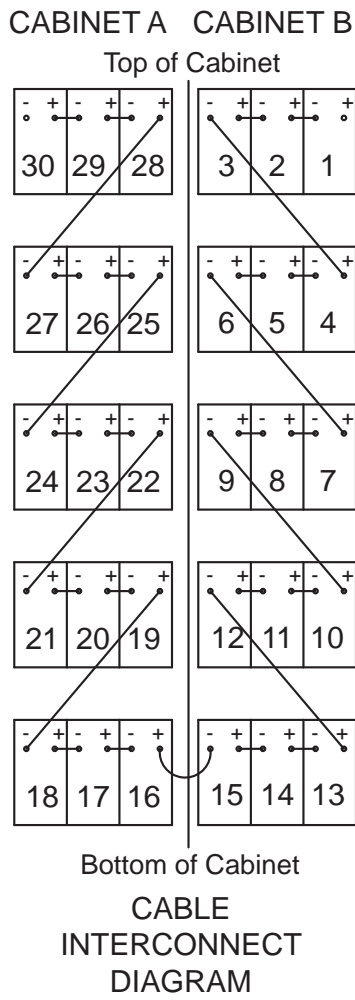
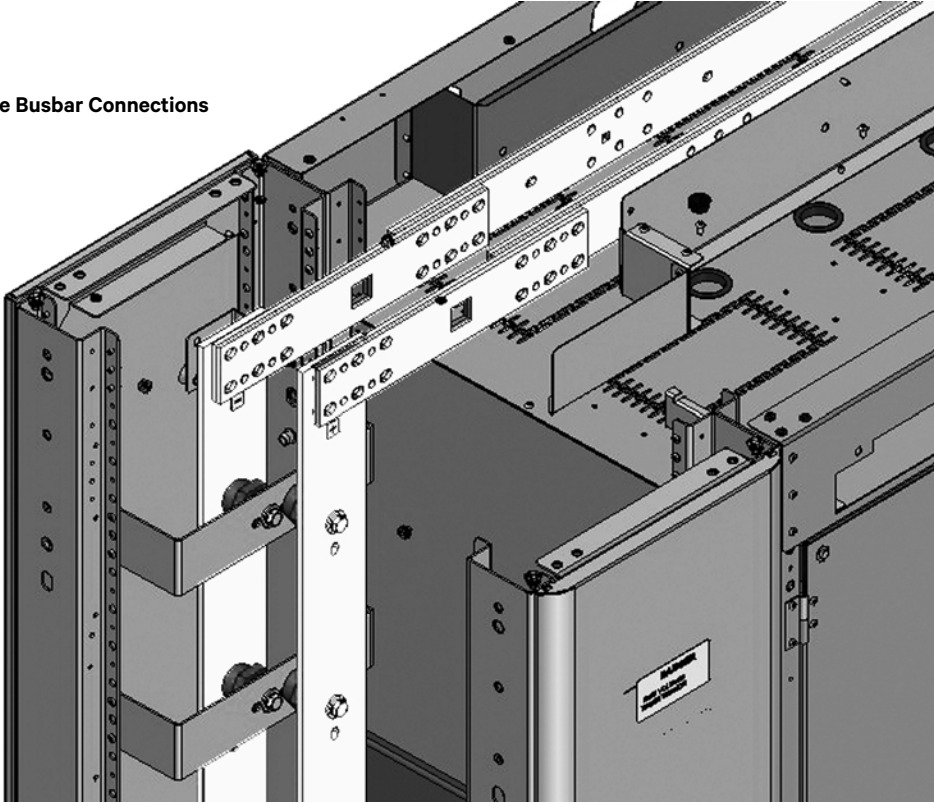


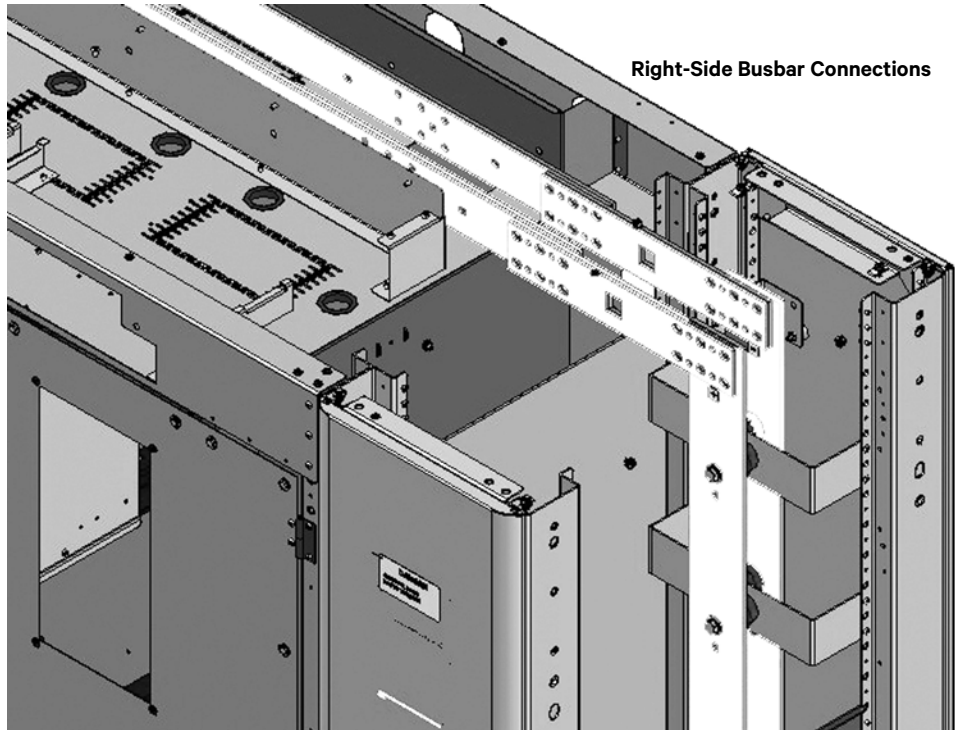
Figure 55 Busbar connection between battery cabinet and attached junction cabinet

Left-Side Busbar Connections



This connection is the same for top-terminal (12V) battery cabinets and front-terminal (16V) battery cabinets.

Right-Side Busbar Connections



# 4.0 SPECIFICATIONS

**Table 19** Liebert NXL™ battery cabinet specifications

Battery Cabinet Parameters	Values	
	Top-Terminal Cabinet	Front-Terminal Cabinet
Battery Type	VRLA (Valve Regulated Lead Acid)	
Nominal Battery Bus, VDC	480V	
Battery Float Voltage, VDC	540V	
Minimum EOD Voltage, VDC	384V (for VRLA / Flooded Lead Acid)	
<b>Physical Parameters and Standards</b>		
Width, in. (mm) <sup>1</sup>	Standard Width: 56.5 (1435) Reduced Width: 48.3 (1227)	63.0 (1600)
Depth, in. (mm) <sup>2</sup>	33.5 (850)	33.5 (850)
Height, in. (mm)	76.8 (1950)	76.8 (1950)
Weight, lb (kg) approx.	<b>Table 22</b>	
Standard Color	Black (ZP-7021)	
Front Door Opening (for serviceability)	More than 180°	
Degree of Protection for UPS Enclosure	IP 20 (with and without front door open)	
Minimum Clearance, Top	24" (610mm)	
Minimum Clearance, Back	0"	
Minimum Clearance, Sides	0"	
Cable Entrance	Top or Bottom	
<b>Standards &amp; Conformities</b>	UL 1778; CSA 22.2 107.3 FCC Part 15, Class A; ISTA Procedure 1H; WEEE; IBC 2012/CBC 2010	
<b>Environmental Parameters</b>		
Storage Temperature Range, °F (°C)	-4°F to 104°F (-20°C to 40°C) <sup>3</sup> 74°F to 80°F (23-27°C) for optimal battery life	
Operating Temperature Range, °F (°C)	32°F to 104°F (0 to 40°C) 74°F to 80°F (23-27°C) for optimal battery life	
Relative Humidity	up to 95% Non-Condensing (Operating and Non-Operating)	
Maximum Altitude Above MSL, ft (m)	4920 (1500) (as per IEC 62040/3) - 1% Maximum kW derate / 100m rise between 1500-3000m	

1. Width dimensions are with side panels attached. Subtract 1.4" (35mm) for dimensions without side panels.
2. Depth dimensions include the front door and rear panel.
3. Contact the factory about storage at temperatures outside this range.

**Table 20 Liebert NXL™ Junction Cabinet specifications**

Battery Specifications	Value		
	500-750kVA Attached	Stand-Alone	800-1100kVA Attached
Nominal Battery Bus, VDC	480V		
Battery Float Voltage, VDC	540V		
Minimum EOD Voltage, VDC	384V (for VRLA / Flooded Lead Acid)		
<b>Physical Parameters</b>			
Width, in (mm) <sup>1</sup>	15.5 (393)	30.9 (785)	17.5 (445)
Depth, in (mm) <sup>2</sup>	33.5 (850)	33.5 (850)	33.5 (850)
Height, in (mm)	76.8 (1950)	76.8 (1950)	76.8 (1950)
Weight, lb (kg) approx.	255 (115)	400 (180)	255 (115)
Color	Black (ZP-7021)		
Degree of Protection for UPS Enclosure	IP 20		
Minimum clearance, Top	24" (610mm)		
Minimum clearance, Back	0"		
Minimum clearance, Sides	0"		
Location of cable entrance	Top or Bottom		
<b>Standards and Conformities</b>	UL 1778; CSA 22.2 107.3; FCC Part 15, Class A ISTA Procedure 1H; WEEE; IBC 2012/CBC 2010		
<b>Environmental</b>			
Storage Temperature Range, °F (°C)	-13°F to 158°F (-25°C to 70°C)		
Operating Temperature Range, °F (°C)	32°F to 104°F (0 to 40°C)		
Relative Humidity	Maximum 95% Non-Condensing (Operating and Non-Operating)		
Maximum Altitude above MSL, ft (m)	4920 (1500) (as per IEC 62040/3) - 1% maximum kW derate / 328ft rise between 4900-9800ft (100m rise between 1500-3000m)		

1. Width dimensions are with side panels attached. Subtract 1.4" (35mm) for dimensions without side panels.
2. Depth dimensions include the front door and rear panel.

**Table 21 Alber® battery monitoring option specifications**

Electrical Data	Value
Input Voltage	220-600VAC
Input Current	< 0.5A
Frequency	60Hz

**Table 22 Battery cabinet weights and breaker frame size**

Manufacturer	Battery Code	Battery Model #	Weight, lb. (kg)	Breaker Frame Size	Torque Value in-lb (Nm)	
<b>C&amp;D</b>	PR	UPS12-300MR	3465 (1572)	350AT/600AF	110 (12.4)	
	QU	UPS12-305PLP	3465 (1572)	400AT/600AF		
	RR	UPS12-350MR	3825 (1735)	400AT/600AF		
	SU	UPS12-355PLP	3825 (1735)	450AT/600AF		
	UR	UPS12-400MR	4215 (1912)	500AT/600AF		
	UU	UPS12-405PLP	4215 (1912)	500AT/600AF		
	WR	UPS12-490MR	5175 (2347)	500AT/600AF		
	WU	UPS12-495PLP	5175 (2347)	600AT/600AF		
	XR	UPS12-540MR	5225 (2370)	600AT/600AF		
	XU	UPS12-545PLP	5225 (2370)	600AT/600AF		
	ZR	UPS12-600MR	5585 (2533)	700AT/1200AF		
	ZU	UPS12-605PLP	5585 (2533)	700AT/1200AF		
<b>Energys</b>	PX	12HX300	3525 (1599)	350AT/600AF	65 (7.3)	
	RX	12HX330	3965 (1798)	400AT/600AF		
	UX	12HX400	4375 (1984)	450AT/600AF		
	WX	12HX505	5295 (2402)	600AT/600AF		
	XX	12HX540	5465 (2479)	600AT/600AF		
	PG	XE60	3155 (1431)	700AT/1200AF		60 (6.8)
	VG	XE95	4275 (1939)	800AT/1200AF		
	2K	16HX800F-FR	8500 (3856)	<b>Liebert eXL</b> 800AT/1200AF		100 (11.3)
				<b>Liebert NX 225-600</b> 225kW: 600AT/600AF 250kW: 700AT/1200AF 300-600kW: 800AT/1200AF		
				<b>Liebert NXL</b> 225kW 700AT/1200AF 270-1100kW: 800AT/1200AF		
	4K	16HX925F-FR	9100 (4128)	<b>Liebert eXL</b> 900AT/1200AF		100 (11.3)
				<b>Liebert NX 225-600</b> 225kW 600AT/600AF 250kW 700AT/1200AF 300kW 800AT/1200AF 400-600kW: 900AT/1200AF		
<b>Liebert NXL</b> 225kW 700AT/1200AF 270kW 800AT/1200AF 360-1100kW: 900AT/1200AF						
<b>East Penn</b>	QA	HR3000	3565 (1617)	400AT/600AF	65 (7.3)	
	TA	HR3500	3965 (1798)	450AT/600AF		
	VA	HR4000	4375 (1984)	500AT/600AF		
	WA	31HR5000	5095 (2311)	500AT/600AF		
	YA	HR5500	5455 (2474)	600AT/600AF		

**Table 23 Recommended lug sizes**

Cable Size	T&B Copper One Hole	T&B Copper Two Hole	T&B Aluminum One Hole	T&B Aluminum Two Hole
#8AWG	54930BE	54850BE	60104-TB	—
#6AWG	54905BE	256-30695-868	60109-TB	—
#4AWG	54906BE	256-30695-733	60114-TB	—
#2-3AWG	54942BE	54811BE	60120	—
#1AWG	54947BE	54857BE	60126	—
#1/0AWG	54950BE	256-30695-593	60132	—
#2/0AWG	54951BE	54862BE	60138	60238
#3/0AWG	54965BE	54864BE	60144	60244
#4/0AWG	54970BE	54866BE	60150	60250
250kcmil	54913BE	54868BE	60156	60256
300kcmil	54914BE	54870BE	60162	60262
350kcmil	54915BE	54872BE	60165	60267
400kcmil	54916BE	54874BE	60168	60269
500kcmil	54918BE	54876BE	60171	60273
600kcmil	54920BE	54878BE	60176	60275
750kcmil	54922BE	54880BE	60178	60277

**Table 24 Torque specifications, unless otherwise labeled**

Nut and Bolt Combinations		
Bolt Shaft Size	Grade 2 Standard lb-in (Nm)	Electrical Connections with Belleville Washers lb-in (Nm)
1/4 (M6)	53 (6.0)	46 (5.2)
5/16 (M8)	107 (12)	60 (6.8)
3/8 (M10)	192 (22)	95 (11)
1/2 (M12)	428 (48)	256 (29)
Circuit Breakers with Compression Lugs (For Power Wiring)		
Current Rating	lb-in (Nm)	—
400 - 1200 Amps	300 (34)	—
Circuit Breakers with Compression Lugs (For Control Wiring)		
AWG Wire Size or Range	lb-in (Nm)	—
#22 - #14	3.5 to 5.3 (0.4 to 0.6)	—



## NOTES





## **TECHNICAL SUPPORT / SERVICE**

### **Web Site**

[www.vertivco.com](http://www.vertivco.com)

### **Monitoring**

[liebert.monitoring@vertivco.com](mailto:liebert.monitoring@vertivco.com)

800-222-5877

Outside North America: +00800 1155 4499

### **Three-Phase UPS & Power Systems**

800-543-2378

Outside North America: 614-841-6598

## **LOCATIONS**

### **United States**

1050 Dearborn Drive

P.O. Box 29186

Columbus, OH 43229

### **Europe**

Via Leonardo Da Vinci 8

Zona Industriale Tognana

35028 Piove Di Sacco (PD) Italy

+39 049 9719 111

Fax: +39 049 5841 257

### **Asia**

29/F, The Orient Square Building

F. Ortigas Jr. Road, Ortigas Center

Pasig City 1605

Philippines

+63 2 687 6615

Fax: +63 2 730 9572

---



**VertivCo.com | Vertiv Headquarters, 1050 Dearborn Drive, Columbus, OH, 43085, USA**

© 2016 Vertiv Co. All rights reserved. Vertiv and the Vertiv logo are trademarks or registered trademarks of Vertiv Co. All other names and logos referred to are trade names, trademarks or registered trademarks of their respective owners. While every precaution has been taken to ensure accuracy and completeness herein, Vertiv Co. assumes no responsibility, and disclaims all liability, for damages resulting from use of this information or for any errors or omissions. Specifications are subject to change without notice.

SL-25418\_REV2\_12-16