



UNI JET

ИБП Borri B8031FXS - технические спецификации. Юниджет

Постоянная ссылка на страницу: <https://www.uni-jet.com/catalog/ibp/online-ibp/borri-b8031fxs/>



TECHNICAL DATA SHEET “B8031 FXS”

10 – 15 – 20 kVA 3Ph_(In) – 1Ph_(Out)

GENERAL INFORMATION

POWER		kVA	10	15	20
UPS Type		ON LINE – Double Conversion			
Nominal output power (Cosφ 0.9)		kVA	10	15	20
Nominal output power (Cosφ 1.0)		kW	9	13.5	18
Efficiency (AC ÷ AC) (ON LINE - Double Conversion)	@25% load	%	> 88		
	@50% load		> 90		
	@75% load		> 91		
	@100% load		> 92		
Efficiency (AC ÷ AC) (Eco Mode)		%	> 98		
Heat dissipation at nominal load and voltage		kW	0.782	1.170	1.564
		kcal/h	0.673	1.005	1.344
UPS ambient temperature		°C	0 ÷ 40		
BATTERY ambient temperature		°C	0 ÷ +25		
UPS storage temperature		°C	-10 ÷ +70		
BATTERY storage temperature		°C	-10 ÷ +60		
Relative humidity (non condensing)		%	< 95		
Altitude		m	< 1000 (above sea level)		
Power derating for altitude > 1000 m			According to “IEC62040-3” 1% power derating every 100m above 1000m up to max 2000m		
Ventilation			Forced		
Requested cooling air volume		m ³ /h	500	500	600
Audible noise level (according to IEC EN 62040-3)		dB	< 52 db		
Standard battery type lead acid		n° cells	2 x 180 2 X 186		
Protection degree			IP 20		
Electromagnetic compatibility EMI			According to “IEC EN 62040-2” (CE marking)		
Safety			IEC EN 62040-1		
Test and performance			IEC EN 62040-3		
Paint			RAL 7016		
Accessibility			Front and top		
Installation			10 cm from the wall		
Dimensions		mm	L = 450 P = 640 H = 1200		
Weight (with battery)		kg	Min. 175 Max. 285	Min. 260 Max. 275	Min. 260 Max. 275
Weight (without battery)		kg	100	110	110
Static load (with battery)		kg/m ²	Min. 583 Max. 878	Min. 859 Max. 912	Min. 859 Max. 912
Static load (without battery)		kg/m ²	321	364	381
Input/Output cable connection			Bottom side		
Transport			By wheels		
Transport mechanical stress			According to “IEC EN 62040-3”		
Design standards			“IEC EN 62040” “ISO 9001:2008” - “ISO 14001”		

Rev.	Descrizione Description	Data Date	Emesso Issued	Approvato Approved	Lingua Language	Pagina Page	di Pag. of Pag.
/	First Issue	15/06/11	L. Fognani	P. Conti	E	1	6
A	Revision JSE414887	10/11/11	L. Fognani	P. Conti			
B	Revision JSE416782	13/03/13	L. Fognani	P. Conti			
					Codice / Code JUD414236		

Free contact interface		On request
Serial communication interface		Standard: RS232 - USB Optional: RS485 (ModBus protocol)
Parallel configuration (optional)		Up to 5+1 (Redundant parallel) Up to 6 (Power parallel)

BLOCK DIAGRAM

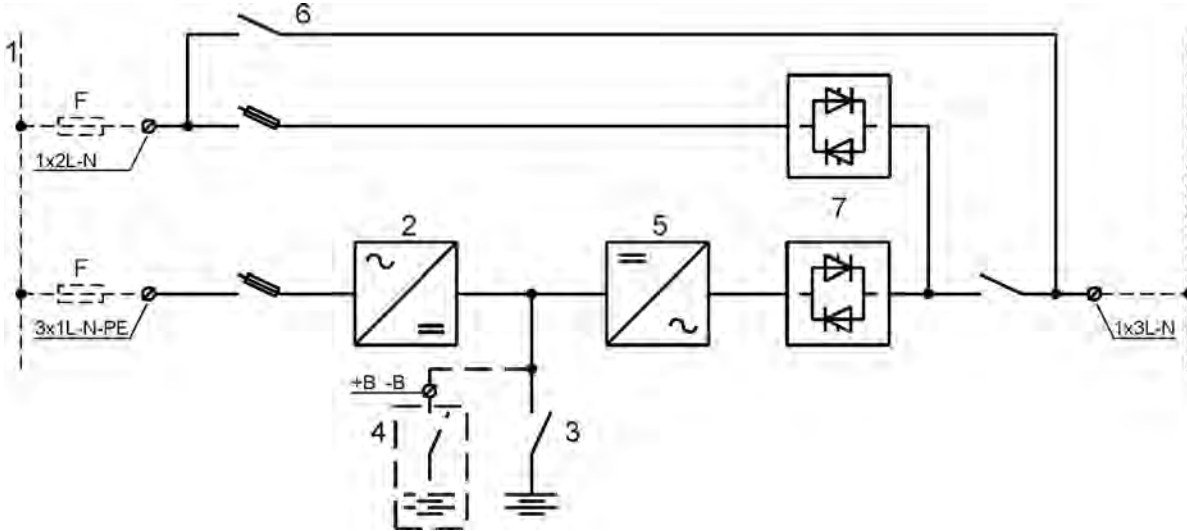

1. Input mains (separate for by-pass and rectifier)
2. Rectifier and battery charger
3. Maximum internal battery: 3,3Ah, 7,2Ah and 9Ah – 60 or 62 batteries
4. Optional external battery
5. Inverter
6. Emergency line (by-pass with backfeed contactor)
7. Inverter (SSI) and by-pass (SSB) static switch

UPS INPUT: RECTIFIER AND BATTERY CHARGER

POWER		kVA	10	15	20
Input			Three-phase + Neutral		
Nominal input voltage range		Vac %	400 -20/+15		
Input frequency range		Hz %	50 – 60 ±5 / ±10 adjustable		
Input power factor			> 0.99		
Input current THD at nominal voltage and THDV <0.5%	@25% load	%	20 <		
	@50% load		8 <		
	@75% load		6 <		
	@100% load		4 <		
DC output voltage accuracy		%	+/- 1%		
DC output voltage ripple		% rms	2% rms		
Battery recharging characteristic			IU (DIN 41773)		
Maximum recharging current - at nominal load		A	6	10	6
Bridge rectifier type			IGBT PFC		
Input protection			Fuses		
Inrush input current		A	< maximum nominal current		
Earth leakage current		mA	< 22		
Nominal current absorbed from mains (at nominal load and battery charged)		A	14	21	26
Maximum current absorbed from mains (at nom. Load, max. recharging current and nominal input voltage)		A	21	28	35
Settable walk-in		sec	Sectable from 5" to 30"		
Settable hold-off		sec	Sectable from 1" to 300"		

BATTERY

POWER	kVA	10	15	20
Maximum internal battery		60 or 62 batteries 3,3AH - 7,2AH - 9AH		
Standard type		Maintenance free		
Cells number (settable)		2x180 or 2x186		
Floating voltage at 25°C (settable)	Vdc	2x406 or 2x418		
Minimum battery discharge voltage	Vdc	Settable		
Inverter input power (at nominal load)	kW	9.5	14.3	19
Inverter input current (at nominal load and minimum Vdc)	A	13.5	20.5	27
Battery Protection (external to the UPS)		Fuses		
Battery Test		Included as standard		

UPS OUTPUT: INVERTER

POWER	kVA	10	15	20
Inverter Bridge		Modular IGBT (transformerless)		
Nominal output power (Cos ϕ 0.9)	kVA	10	15	20
Nominal output power (Cos ϕ 1.0)	kW	9	13.5	18
Efficiency (DC ÷ AC)	%	> 95		
Output		Single phase		
Nominal output voltage (selectable)	Vac	220-230-240		
Output voltage stability		Class 1		
- Static (balanced Load)	%	± 1		
- Static (unbalanced Load)	%	± 2		
- Dynamic (step load 20%÷100%÷20%)	%	± 5		
- Output voltage recovery time (after step load)	ms	< 20		
- IEC EN 62040-3		Class 1		
Output frequency (selectable)	Hz	50 - 60		
Output frequency stability		± 0,001		
- Free running quartz oscillator	Hz	± 2 (other on request)		
- Inverter sync. with mains	Hz	± 1		
- Slew rate	Hz/s	± 1		
Nominal Output Current (@ 400 Vac output)				
- Cos ϕ 0.9 (leading and lagging)	A	43	65	87
- Cos ϕ 1 (purely resistive load)		39	58	78
Overload capability		125% for 10 min 125%/150% for 30 sec >150% for 10 sec		
Short circuit current	A	70	104	140
Short circuit characteristic		Elect. short circuit protection, current limited at above values. Automatic stop after 5 seconds		
Selectivity		Within ½ cycle (Fuse GL 20% In)		
Output waveform		Sinusoidal		
Output harmonic distortion		Fully compliant		
- Linear Load	%	< 2		
- Non Linear Load		< 5		
- IEC EN 62040-3		Fully compliant		
Max crest factor without derating		3 : 1		

UPS OUTPUT: BY PASS

Automatic static by-pass		Electronic thyristor switch
Protection		Fuses
Bypass	Vac	Single phase
Nominal Voltage (selectable)	Vac	220 – 230 – 240
Range	%	±10
Nominal Frequency (selectable)	Hz	50-60
Range	%	±(1÷5) ±10 adjustable
Transfer mode		Without break
Transfer inverter → automatic bypass		In case of : <ul style="list-style-type: none"> - Short circuit - Battery end of discharge - Inverter test - Inverter not operating
Retransfer automatic bypass → inverter		- Automatic - Block on bypass after 6 transfers within 2 minutes, reset by front panel
Overload Capability	%	150 continuously 1000 for 1 Cycle
Manual By-Pass		Standard: <ul style="list-style-type: none"> - Electronically controlled - No break
Back feed protection		Included in basic unit

OPTIONS

1. BATTERY TEMPERATURE VOLTAGE COMPENSATION
2. INSULATION TRANSFORMER ON BY-PASS
3. VOLTAGE ADAPTATION AUTO-TRANSFORMERS
4. RELAY CARD (Eight signals Alarms/Statuses), Free relay contact
5. SERIAL INTERFACE RS-485 (MOD-BUS protocol)
6. SNMP ADAPTER
7. REMOTE MONITORING PANEL
8. PARALLEL CARD INTERFACE KIT
9. EXTERNAL BATTERY CABINET
10. WALL MOUNTED FUSED SWITCH BOX
11. SPECIAL PAINT
12. LOAD-SYNC BUS CARD INTERFACE KIT
13. DIESEL GENERATOR
14. EXTERNAL EPO AUXILIARY CONTACT
15. EXTERNAL MCB AUXILIARY CONTACT

OTHER SOFTWARE SELECTABLE FEATURES

1. OFF-LINE
2. RECTIFIER WALK-IN TIME
3. RECTIFIER DELAY ON STARTUP (HOLD-OFF TIME)
4. FREQUENCY CONVERTER MODE