



**uni jet**

## **ИБП Eaton 9E - руководство пользователя. Юниджет**

Постоянная ссылка на страницу: <https://www.uni-jet.com/catalog/ibp/online-ibp/eaton-9e/>



powerquality.eaton.com

# Eaton 9E

6-20kVA



**EATON**  
Powering Business Worldwide

# CONTENT:

<b>1. Introduction .....</b>	<b>1</b>
1.1 Safety instruction .....	1
1.2 Certification Standards.....	3
1.3 Special Symbols .....	4
<b>2.Presentation.....</b>	<b>5</b>
2.1 Model List .....	5
2.2 Electrical structure .....	5
2.3 UPS views .....	7
<b>3.Installation .....</b>	<b>12</b>
3.1 Unpacking.....	12
3.2 Package content.....	13
3.3 Connection .....	13
<b>4.OPERATION .....</b>	<b>24</b>
4.1 Display and Buttons .....	24
4.2 Operating UPS.....	28
4.3 Configuration .....	30
4.4 Trouble shooting .....	32
4.5 Alarm codes.....	34
<b>5.Technical data .....</b>	<b>35</b>

# 1. Introduction

## 1.1 Safety instruction

- The UPS must be installed and maintained exclusively by qualified staff. See installation and operation instructions before connecting to the supply.
- The UPS must be installed with an earth connection. It has a high leakage current. The first wire to be connected is the earth wire, which must be connected to the terminal marked PE (yellow/green).
- The UPS generates a leakage current of over 3.5 mA. The leakage current of the load should be added to that of the UPS on the protective earth wire.
- The UPS needs a neutral connection to work properly. Operation without Neutral may damage the unit.
- A readily accessible disconnect device shall be incorporated in the building installation wiring for permanently connected equipment.
- The UPS generates hazardous electric voltages inside it even when the input and/or battery switches are open. The inside of the UPS is protected by safety guards that are not to be removed by non-qualified staff. All installation and maintenance or other operations that entail gaining access to the inside of the UPS require the use of tools and are to be performed exclusively by qualified staff.
- The UPS contains an energy source: the batteries. All terminals and sockets may be powered even when the UPS is not connected to the mains.
- The total battery voltage is potentially hazardous: it may cause an electric shock. The compartment containing the batteries is protected by safety guards, which are not to be removed by non-qualified staff.

All battery installation and maintenance operations entail gaining access to the inside of the UPS and require the use of tools: these operations are to be performed exclusively by qualified staff.









- The batteries replaced are to be considered as toxic waste and treated accordingly. Dispose of used batteries according to the instructions. Do not throw the batteries into fire: they could explode. Do not attempt to open the battery casing: no maintenance work can be done on them. In addition, the electrolyte is hazardous for the skin and eyes and may be toxic.
- Risk of explosion if battery is replaced by an incorrect type.
- Do not turn on the UPS if you see any leaks of liquid or a white powder residue.
- Make sure that no water, liquid in general and/or other foreign matter gets inside the UPS.
- Under hazardous conditions, turn off the UPS at the “1/0” main power switch and open all the isolators present (see the user manual to locate the “1/0” main power switch and the isolators).
- Do not open the battery fuse holders while the UPS is powering the load from the batteries. An interruption of the battery DC voltage may cause an electric arc and result in breakage of the equipment and/or fire.
- The energy required to power the load is provided by the batteries in the event of a power failure. If the battery protection were open, the load would be powered off.
- Fuses have to be replaced with the same type if necessary.
- To connect external battery cabinets, use the expansion cable suggested by the manufacturer in this manual.

## 1.2 Certification Standards

<b>Safety</b>
IEC 62040-1:2008 IEC 60950-1:2005 (Modified)
<b>EMC</b>
Conducted Emission: IEC 62040-2. Category C3
Radiated Emission: IEC 62040-2. Category C3
ESD:IEC 61000-4-2. Contact: Level 2, Air discharge: Level 3
RS:IEC 61000-4-3. Level 3
EFT:IEC/EN 61000-4-4. Level 4
Surge:IEC/EN 61000-4-5. Level 4
CS:IEC/EN 61000-4-6. Level 3
MS:IEC/EN 61000-4-8. Level 3
Voltage Dips, short interruptions and voltage variations:IEC/EN 61000-4-11
Warning: This is a product for commercial and industrial application, in other environment installation restrictions or additional measures may be needed to prevent disturbances. Additional curbs may be needed while output wiring length is more than 10m or communication wiring length is more than 3m.

## 1.3 Special Symbols

The following are examples of symbols used on the UPS or accessories to show you the important information:

Symbol and Explanation			
Symbol	Explanation	Symbol	Explanation
	Alert you to pay special attention		Direct current source (DC)
	Caution of high voltage		Protective ground
	Turn on or turn off the UPS		Recycle
	Alternating current source (AC)		Do not dispose with ordinary trash

# 2.Presentation

9E series UPS uses ON-LINE double conversion technology, resulting in the highest levels of reliability and maximum protection for critical loads.

## 2.1 Model List

Model	Power Ratings	PF	Voltage (Output)
9E6Ki	6kVA/4.8kW	0.8	230V (220/240)
9E10Ki	10kVA/8kW Combo	0.8	230V (220/240)
9E10KiXL	10kVA/8kW Combo	0.8	230V (220/240)
9E15Ki	15kVA/12kW Combo	0.8	230V (220/240)
9E20Ki	20kVA/16kW Combo	0.8	230V (220/240)
9E20KiXL	20kVA/16kW Combo	0.8	230V (220/240)
9EEBM180	For 9E6Ki		180V
9EEBM240	For 9E10Ki, 9E10KiXL		240V

“XL” Model: Model with internal supercharger, and without internal batteries. Other models with internal batteries

## 2.2 Electrical structure

9E6Ki

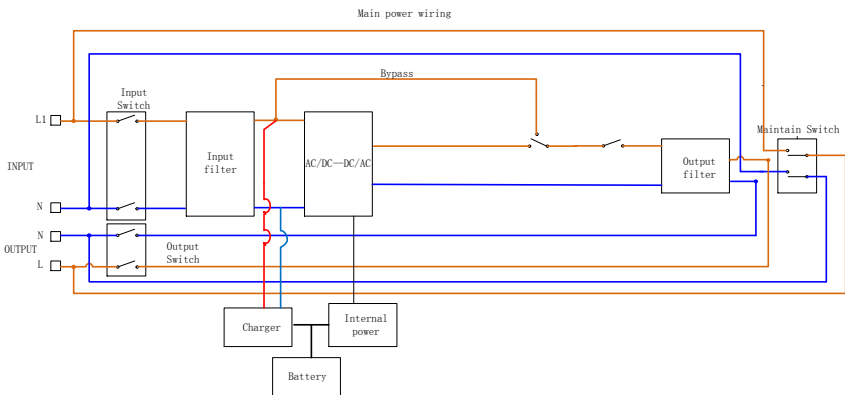



## 9E10Ki, 9E10KiXL

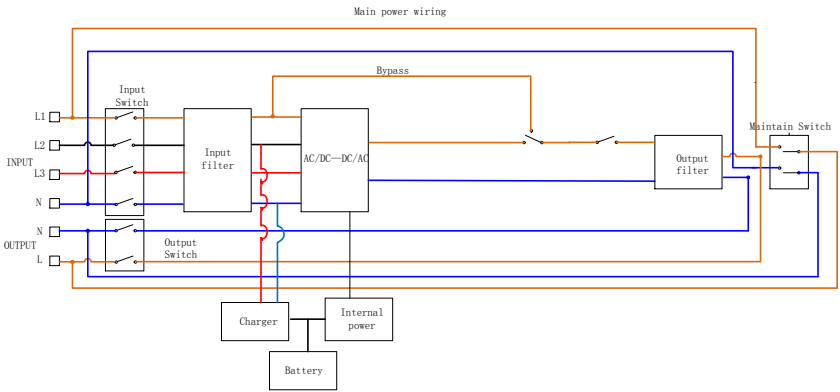

## 9E15Ki, 9E20Ki, 9E20KiXL

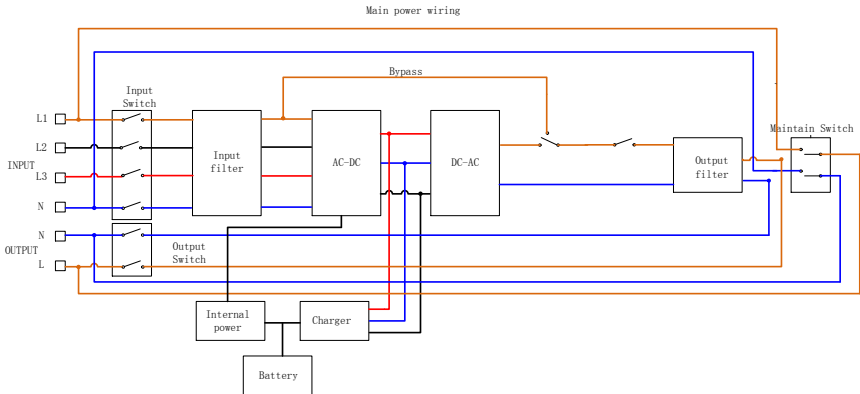

## 2.3 UPS views

### 2.3.1 UPS Front view

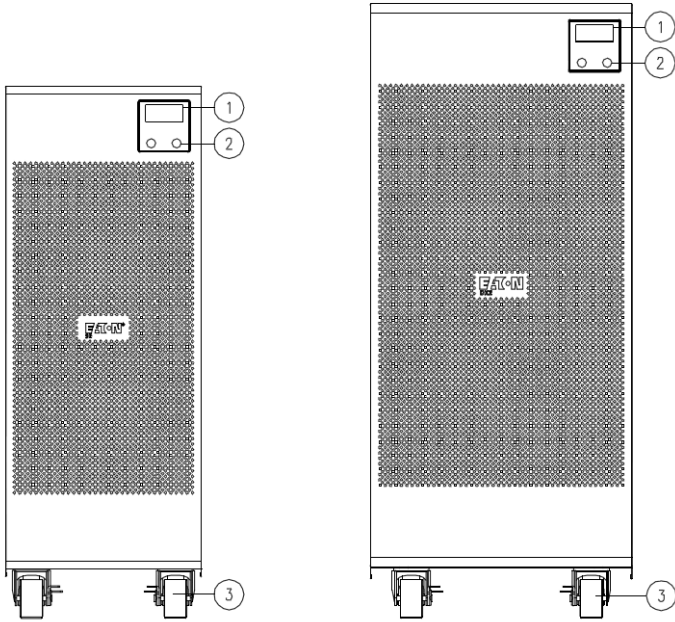

- ① Display
- ② Multipurpose buttons
- ③ Wheels (front wheels swivel and can be locked, fixed rear wheels)

## 2.3.2 UPS Rear view

**9E6Ki**  
With backpanel cover

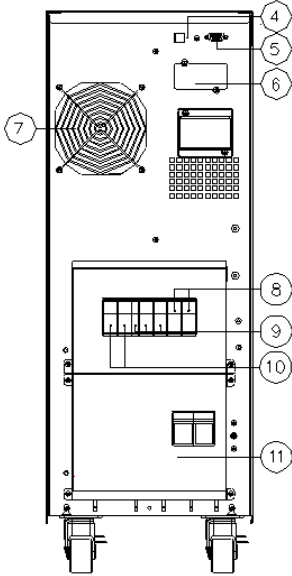

**9E6Ki**  
Without backpanel cover

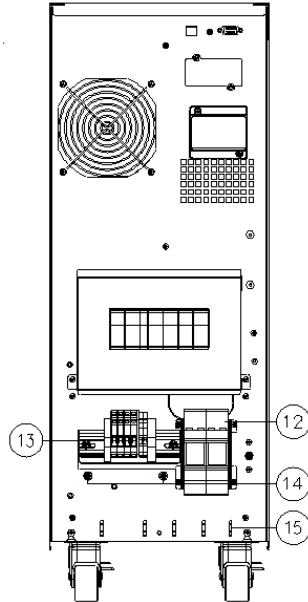

- ④ USB communication port
- ⑤ RS232 communication port
- ⑥ Slot for optional communication card
- ⑦ Cooling fan(s)
- ⑧ Output switch
- ⑨ Manual bypass for maintenance

- ⑩ Input switch
- ⑪ Cover for terminals
- ⑫ Fuse
- ⑬ Terminals for I/O cable connection (refer to related section)
- ⑭ Earthing screws
- ⑮ Tie wrap hold-down

**9E10Ki/9E10KiXL**  
With backpanel cover

**9E10Ki/9E10KiXL**  
Without backpanel cover

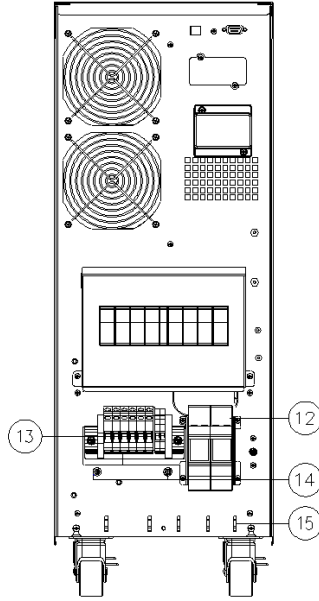
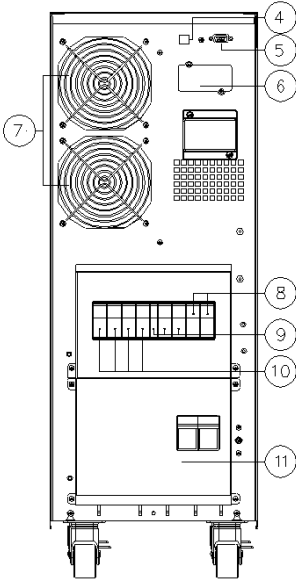

④ USB communication port

⑤ RS232 communication port

⑥ Slot for optional communication card

⑦ Cooling fan(s)

⑧ Output switch

⑨ Manual bypass for maintenance

⑩ Input switch

⑪ Cover for terminals

⑫ Fuse

⑬ Terminals for I/O cable connection (refer to related section)

⑭ Earthing screws

⑮ Tie wrap hold-down

## UPS Rear view

**9E15Ki/9E15KiXL/9E20Ki/9E20KiXL 9E15Ki/9E15KiXL/9E20Ki/9E20KiXL**  
With backpanel cover                      Without backpanel cover

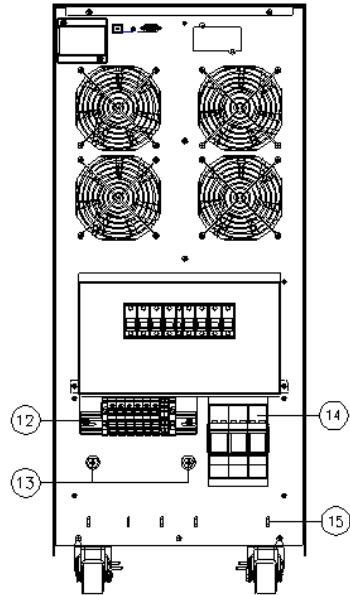
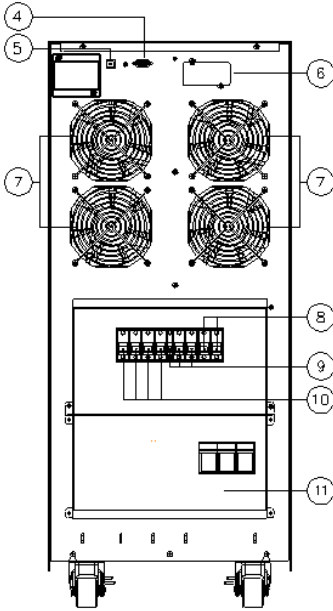

- |  |   |
|--|---|
| ④ RS232 communication port             | ⑩ Input switch  |
| ⑤ USB communication port               | ⑪ Cover for terminals   |
| ⑥ Slot for optional communication card | ⑫ Terminals for I/O cable connection (refer to related section) |
| ⑦ Cooling fans                         | ⑬ Earthing screws   |
| ⑧ Output switch                        | ⑭ Fuse  |
| ⑨ Manual bypass for maintenance        | ⑮ Tie wrap hold-down  |

### 2.3.3 EBM Rear view

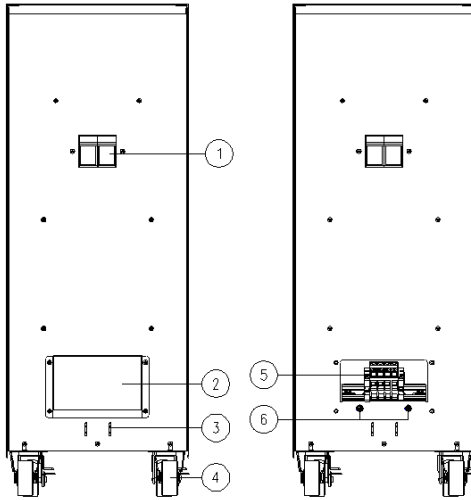

- ① Fuse
- ② Cover for terminals
- ③ Tie wrap hold-down
- ④ Wheels (front wheels swivel and can be locked, fixed rear wheels)
- ⑤ Terminals for I/O cable connection (refer to related section)
- ⑥ Earthing screws

# 3.Installation

## 3.1 Unpacking

1. Cut the straps
2. Open the carton, take off wood board, accessory pack and PE form.
3. Remove carton upward and take out front PE form.
4. Put the wood board (removed at step2) as figure showed. Make sure that the slide rests firmly against the pallet so it remains in place during unloading operations. Pull the UPS from the front with caution when sliding it off the pallet.

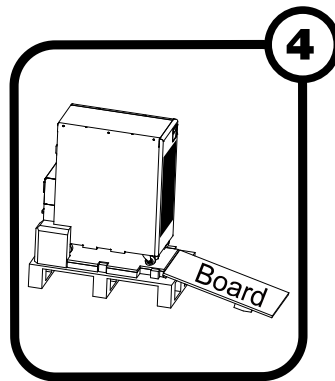
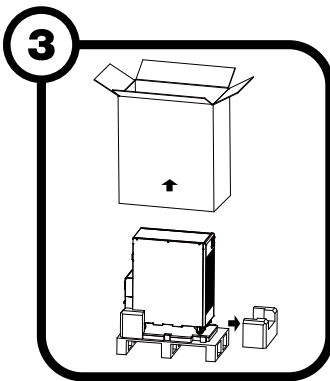
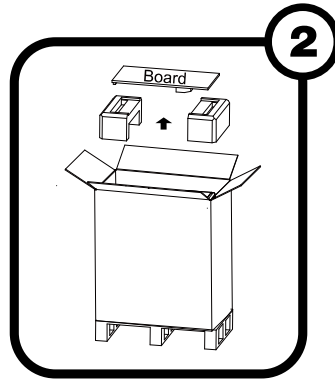
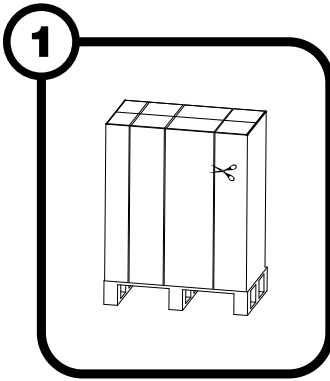

**NOTE:** All parts of the packaging should be kept for future use.

## 3.2 Package content

After opening the packaging, it is first necessary to check the contents.  
The package must contain:

UPS

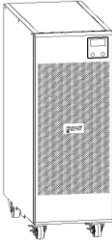

USB cable



RS232 cable



Jumper  
(15/20kVA models only)

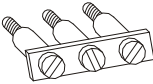

User manual

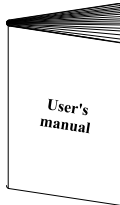

Software CD



## 3.3 Connection

### 3.3.1 Installation requirements

#### Warning:

**Installation must be performed by qualified personnel. The first connection to perform is the protective conductor (earth cable), which must be connected to the screw marketed .**

The UPS, when inserted in an installation, does not alter the existing neutral (system earthing) arrangements.



A differential switch upstream will also be triggered for a fault occurring downstream of the UPS. In calculating reactivity of this switch, account must be taken of the leakage current of the UPS (approx. 8 mA) plus that of the load which come together on the UPS's earth conductor.

UPS input	Differential switch
Single-phase	Type B or Type A
Three-phase	Type B

The neutral arrangements are altered only if there is an isolating transformer or when the UPS operates with a neutral that is disconnected upstream.

**In any case avoid connecting the output neutral with the input neutral or to the earth as this could damage the UPS.**

**Reminder : The UPS needs a neutral connection to work properly. Operation without Neutral may damage the unit.**

**For installation with change in system earthing arrangement or galvanic isolation see below schematic**

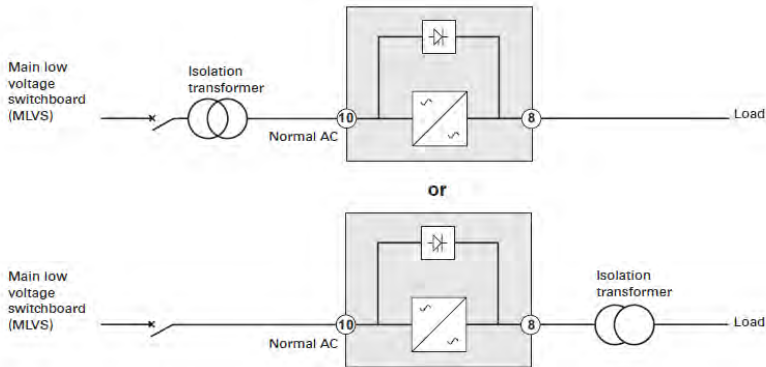
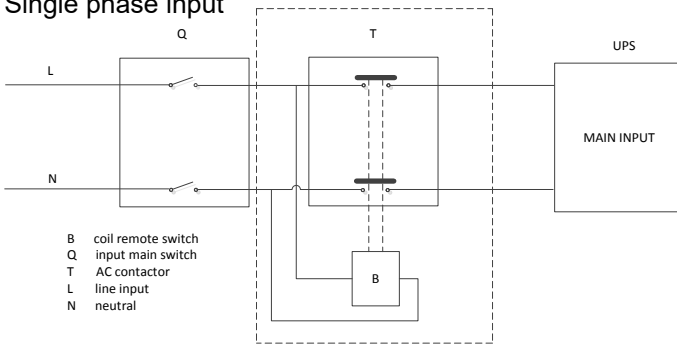

Fig.3-1 Change in SEA or Galvanic isolation

**Notice:** It is required to install an external isolating device against current backfeed between Mains input and UPS. After the device is installed, it must add a warning label with the following wording or the equivalent on the external AC contactor: RISK OF VOLTAGE BACKFEED. Isolate the UPS before operating on this circuit, then check for hazardous voltage between all terminals. The current rating of T - AC contactor should be more than 1.3 times of UPS capacity

### Single phase input



### Three phase input

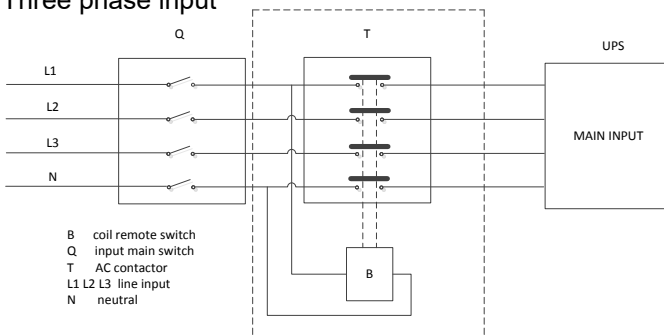

Fig.3-2 Typical external isolating device installation

## 3.3.2 UPS Wiring Connection

To make the mains power and load connections, follow the instructions below:

1. Install a magneto-thermal switch (**63A for 6 & 10kVA versions, 125A for 15 and 20kVA versions**) with intervention curve D upstream of the machine (4 poles for three-phase versions, 2 poles for single-phase versions).
2. The connection terminals to use for the input and output lines are located on the backpanel. Unscrew the 4 screws located on the sides of the cover (one on each side, see figure).
3. Remove the backpanel cover (see figure to the side).

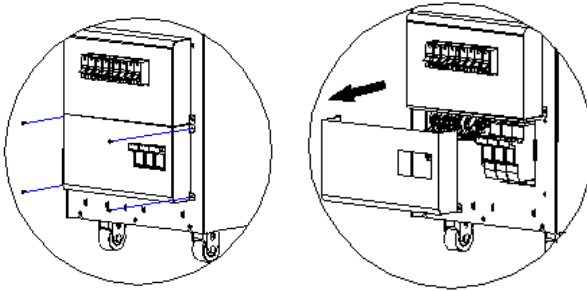

Fig.3-3 Wiring connection

### Single-phase version (9E6Ki only)

4. (**SINGLE-PHASE CONNECTION 9E6KI**): use 3 cables with cross-section  $6 \text{ mm}^2$  (EARTH, N and L) for the input, and 3 cables with cross-section  $6 \text{ mm}^2$  for the output (EARTH, N and L).
5. Connect the wires to the relative terminals, following exactly the instructions given below:

#### Input line

- a - Make sure that the magneto-thermal switch upstream is open.
- b - Connect the earth wire to screw A.
- c - Connect the neutral wire to terminal 2.
- d - Connect the live wire to terminal 1.

#### Output line

- a - Connect the earth wire to screw B.
- b - Connect the neutral wire to terminal 3.
- c - Connect the live wire to terminal 4.

## R.E.P.O.

- a - The REPO connection (between terminal 5 and 6) is normally open.  
For more information please refer to the REPO section of this manual

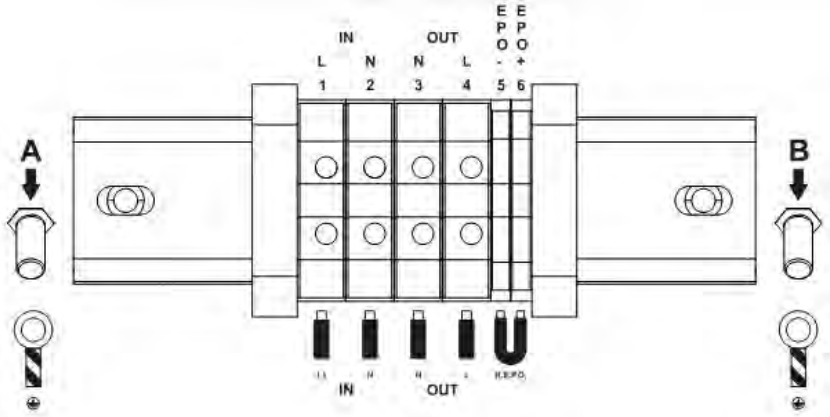

Fig.3-4 6K terminal view

6. Tighten the terminals well, close the backpanel cover and secure it with the screws taken out earlier.

The suggested tighten force is 1.2~1.6Nm.

## Combo version

### Single-phase connection

4. (**SINGLE-PHASE CONNECTION** 9E10KI, 9E10KIXL): use 3 cables of cross-section 10 mm<sup>2</sup> (EARTH, N and L) for the input, and 3 cables of cross-section 10 mm<sup>2</sup> for the output(EARTH, N and L).

(**SINGLE-PHASE CONNECTION** 9E15KI, 9E15KIXL): use 3 cables of cross-section 16 mm<sup>2</sup> (EARTH, N and L) for the input, and 3 cables of cross-section 16 mm<sup>2</sup> for the output(EARTH, N and L).

(**SINGLE-PHASE CONNECTION** 9E20KI, 9E20KIXL): use 3 cables of cross-section 25 mm<sup>2</sup> (EARTH, N and L) for the input, and 3 cables of cross-section 25 mm<sup>2</sup> for the output(EARTH, N and L).

- Short-circuit the input terminals (1, 2 and 3) with the jumper provided in the accessories kit. Connect the wires to the respective terminals, following exactly the instructions below:

**Input line**

- Ensure that the upstream magneto-thermal switch is open.
- Connect the earth wire to screw A.
- Connect the neutral wire to terminal 4.
- Connect the live wire to terminal 1.

**Output line**

- Connect the earth wire to screw B.
- Connect the neutral wire to terminal 5.
- Connect the live wire to terminal 6.

**R.E.P.O.**

- The REPO connection (between terminal 5 and 6) is normally open. For more information please refer to the REPO section of this manual

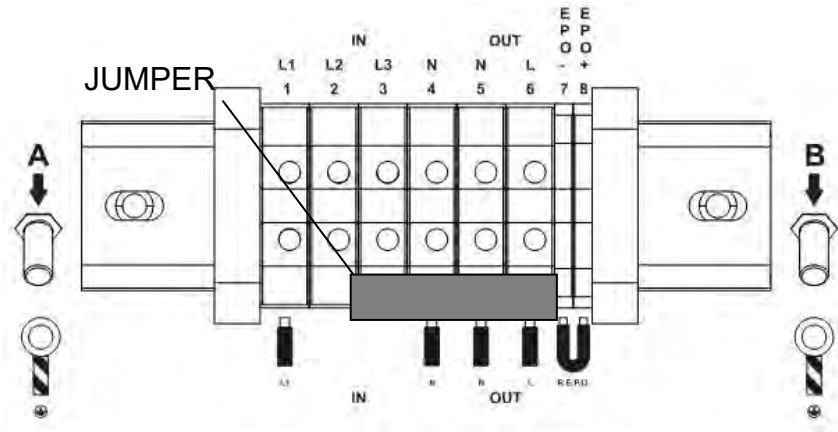

Fig.3-5 10~20K single phase input terminal view

- Tighten the terminals well, close the backpanel cover and secure it with the screws taken out earlier.

For 10 to 15kVA the suggested tighten force is 1.2~1.6Nm. For 20kVA, the suggested tighten force is 2.5~3 Nm.

## Three-phase connection

1. (**THREE-PHASE CONNECTION 9E10KI, 9E10KIXL**): Use 2 cables of cross-section 4 mm<sup>2</sup> (L2 and L3) and 3 with cross-section 10 mm<sup>2</sup> (EARTH, N, L1) for the input (N.B.: L1 and N are of greater cross-section because in bypass operation they have to carry all of the input current). For the output use 3 cables of cross-section 10 mm<sup>2</sup> (EARTH, N and L).

(**THREE-PHASE CONNECTION 9E15KI, 9E15KIXL**): Use 2 cables of cross-section 4 mm<sup>2</sup> (L2 and L3) and 3 of cross-section 16 mm<sup>2</sup> (EARTH, N, L1) for the input (N.B.: L1 and N are of greater cross-section because in bypass operation they have to carry all of the input current). For the output use 3 cables of cross-section 16 mm<sup>2</sup> (EARTH, N and L).

(**THREE-PHASE CONNECTION 9E20KI, 9E20KIXL**): Use 2 cables of cross-section 6 mm<sup>2</sup> (L2 and L3) and 3 of cross-section 25 mm<sup>2</sup> (EARTH, N, L1) for the input (N.B.: L1 and N are of greater cross-section because in bypass operation they have to carry all of the input current). For the output use 3 cables of cross-section 25 mm<sup>2</sup> (EARTH, N and L).

2. Connect the wires to the respective terminals, following exactly the instructions below:

### **Input line**

- a - Ensure that the upstream magneto-thermal switch is open.
- b - Connect the earth wire to screw A.
- c - Connect the neutral wire to terminal 4.
- d - Connect the wires of the phases to terminals 1, 2 and 3 (for L1 use red wire).

### **Output line**

- a - Connect the earth wire to screw B.
- b - Connect the neutral wire to terminal 5.
- c - Connect the live wire to terminal 6.

### **R.E.P.O.**

- a - The REPO connection (between terminal 5 and 6) is normally open. For more information please refer to the REPO section of this manual

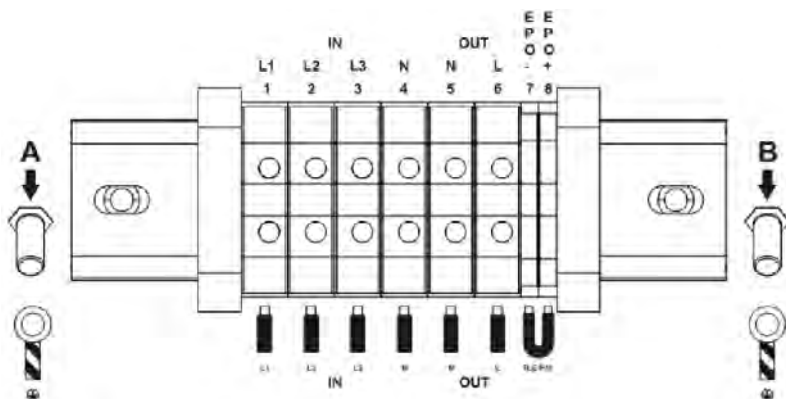

Fig.3-6 10~20K three phase input terminal view

3. Tighten the terminals well, close the backpanel cover and secure it with the screws taken out earlier.

For 10 to 15kVA the suggested tighten force is 1.2~1.6Nm. For 20kVA, the suggested tighten force is 2.5~3 Nm.

### **R.E.P.O.**

The terminal block on the back of the UPS also implements the R.E.P.O. (Remote Emergency Power Off) function that can be used to shut off the UPS remotely in case of an emergency.

For installation, connect to the device's normally open contact .

In case of an emergency, if the stop device is used, the REPO control is closed and the UPS goes into stand-by mode and the load is completely disconnected.

**Attention:** before restarting the UPS, reset the stop device.

The circuitry of the remote control terminal board is self-powered with SELV circuits. Therefore, an external voltage supply is not required. When a contact is closed, a maximum current of 15mA circulates.

All connections with the remote control terminal board are made through a cable which guarantees a double insulation connection.

If you would like to bring the R.E.P.O. control outside, unscrew the two screws securing the lower part of the backpanel cover and remove it (as indicated in the section "Connections"). Then, proceed as follows:

1. Use a  $2 \times 0.75\text{mm}^2$  cable to make the connection with the R.E.P.O. terminals.
2. Insert the screw driver in the square hole and press down to make the round hole terminal open. Then insert the wire into the round hole. Then pull out the screw driver. Connect the two wires of the cable to terminals 5 and 6 (for version **9E6Ki**), 7 and 8 (for versions **9E10Ki**, **9E10KiXL**, **9E15Ki**, **9E15KiXL**, **9E20Ki**, **9E20KiXL**) to be able to remotely shut off the UPS.

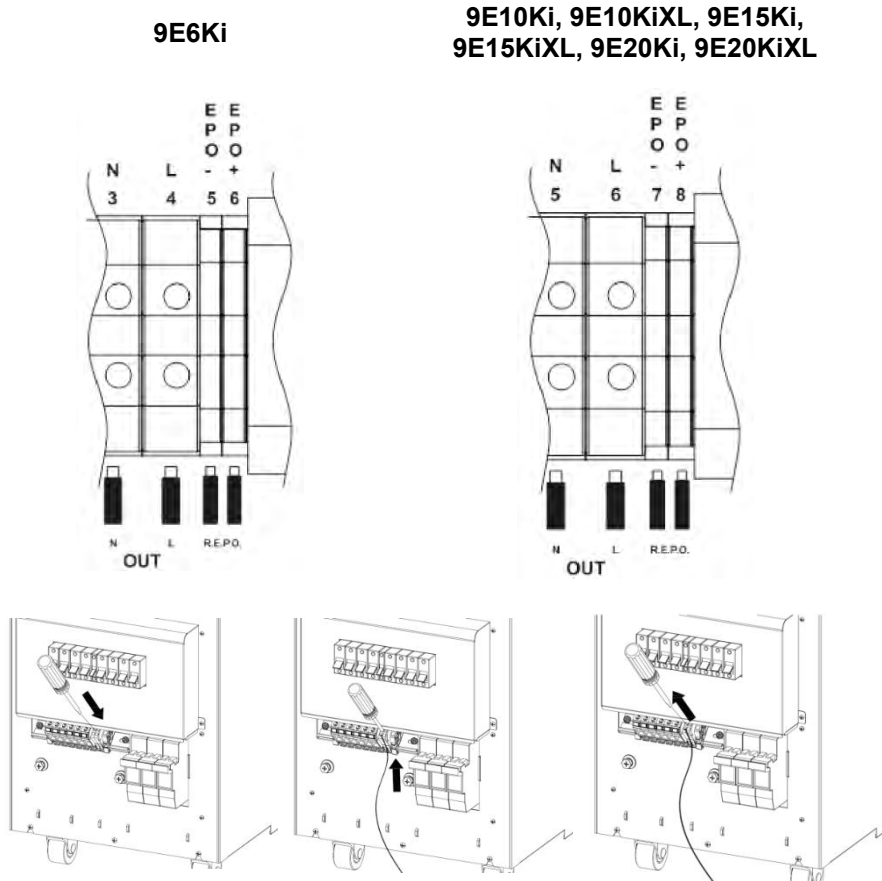

Fig.3-7 EPO terminal connection

3. Close the backpanel cover and secure it with the screws taken out earlier.



### 3.3.3 EBM Wiring Connection

It is possible to connect more than one EBM in order to achieve any level of autonomy without mains power.

In order to ensure the battery runtime displayed is accurate, please set your battery configuration through UPS Configuration Tool (download available here: <http://pqsoftware.eaton.com>).

Connect any Battery Boxes in a cascade as shown in the figure below:

1. **CONNECTION: Use 3 cables with 10 mm<sup>2</sup> section (Earth, +, N and -)**
2. Connect the wires to the relative terminals, following exactly the instructions given below:  
For 9E6Ki, 9E10Ki, 9E10KiXL
  - a - Make sure that the fuse holder of the external battery box is open.
  - b - Connect the earth (PE) wire to EBM's earth (PE) screw
  - c - Connect the positive (+) branch wire to EBM's positive (+) terminal.
  - d - Connect the negative (-) branch wire to EBM's negative (-) terminal.

The suggested tighten force is 1.6Nm. (Detailed wiring diagram see fig 3-9~10)

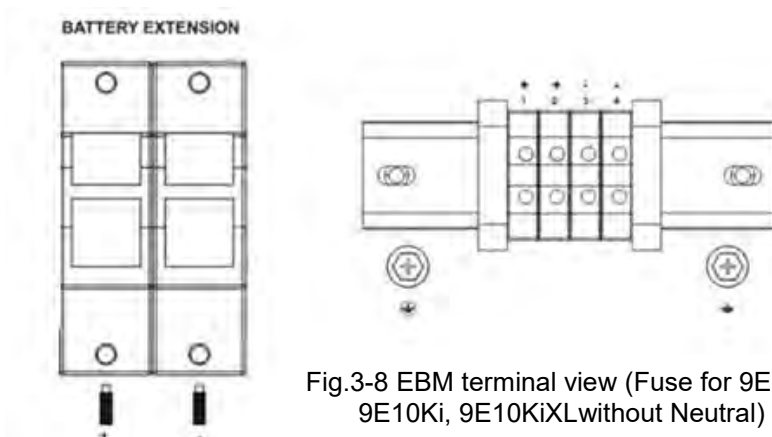

Fig.3-8 EBM terminal view (Fuse for 9E6Ki, 9E10Ki, 9E10KiXL without Neutral)

Versions 9E6Ki, 9E10Ki, 9E10KiXL

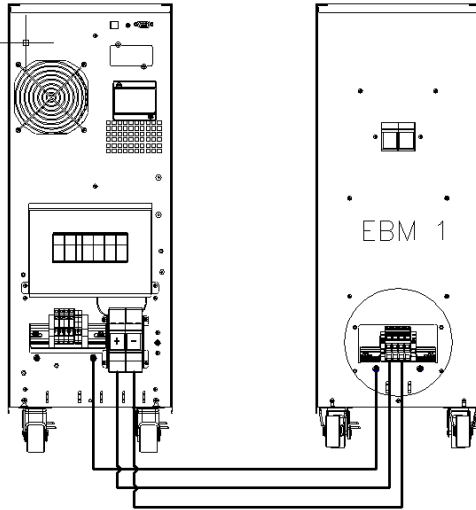

Fig.3-9 EBM terminal connection for 9E6Ki, 9E10Ki, 9E10KiXL With Single EBM

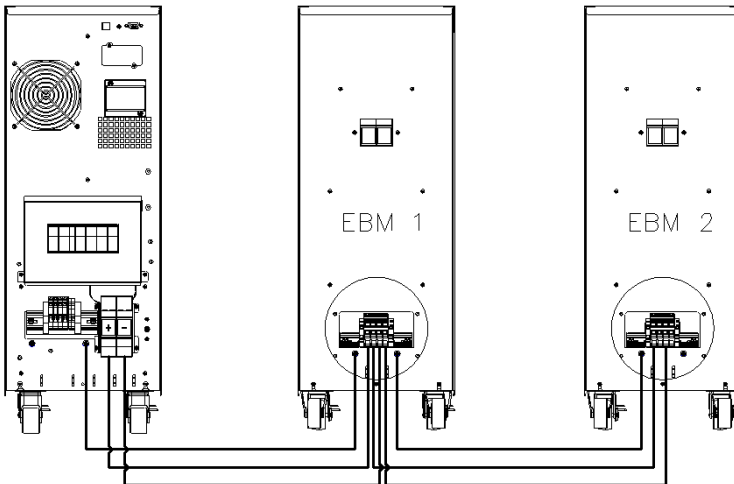

Fig.3-10 EBM terminal connection for 9E6Ki, 9E10Ki, 9E10KiXL With Multiple EBM

**Note: For 9E15Ki, 9E20Ki, 9E20KiXL EBM wiring connection, you should check the 9EEBM manual in EBM package.**

# 4.OPERATION

## 4.1 Display and Buttons



Fig. 4-1 Control Panel

The following tables shows the buttons, LCD indicator and LED indicator status and description:

Table 4-1 Control Buttons Functions



The Button	Function	Illustration
	Turn on	If the UPS is in standby or bypass mode, press >2s, the buzzer will beep once, then the UPS system will be turned on.
	Turn off	If the UPS is in line, battery, HE or battery test mode, press >3s, the buzzer will beep once, then the UPS will be turned off.
	Transfer	If the UPS is in fault mode, and the fault cause has disappeared, press >2s, the buzzer will beep once, fault will be cleared and UPS will turn to standby mode.
	Function key	Battery test on line mode, Press the button >2s
		Mute: Press the button >2s
		Down to next page: Press the button <200ms

Table 4-2 LED indicator

LED name	Colour	Description
Line	Green	It indicates the utility is normal
Battery	Yellow	It indicates the input is connected with battery, and the input power is supplied from the battery.
Bypass	Yellow	It indicates the UPS is in bypass mode, the load current is directly supplied from the utility power
Inverter	Green	It indicates that the inverter is OK and the load is supplied from the inverter.

Note: After UPS power on, all LEDs will be lightened for 2 seconds, and then turn to normal status. When UPS is turning on, 4 LEDs will be lightened one by one until the UPS is turned on successfully.

LED	Line	Battery	Bypass	Inverter
No Output mode	☉			
Bypass mode	●		●	
Line mode	●			●
Battery mode		●		●
Battery test mode		★		●
Fault mode	□		◇	
Warning	□	□	□	□

☉:Utility is normal

●: Lightened constantly

★: Flashing every 4s

◇: Depended on the fault status

□: Depend on the original display

Table 4-3 Buzzer

Priority	UPS condition	Buzzer
1	UPS fault and failure	Continuous
2	Normal mode	No beep
3	Battery/battery test mode	One beep per 4 sec (One beep per 1s when battery low)
4	Bypass mode	One beep per 2 minutes
5	Overload	One beep per 500ms
6	Other alarm	One beep per 1s
7	Manual bypass	One beep per 1s

Note: buzzer alarm can be enable/disable by function button, if buzzer alarm is disabled, all present alarm is muted except that the button press still has a tick beep. Buzzer alarm will be enabled automatically once new alarm arises.

**Interface**

In order to make sure all segments are OK, LCD begins to do self-test after power on. During self-test, all the segments will be lighted for 2 seconds, then the LCD will turn to normal display status.

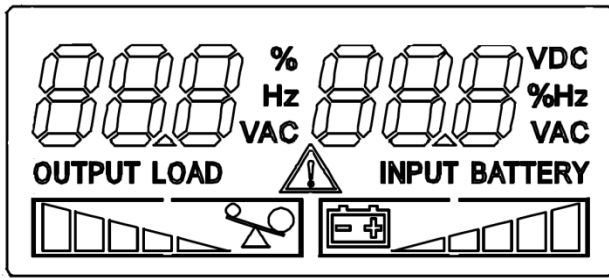





Fig. 4-2 The default LCD display

Icon	Icon name	Description
	Measurements	Display values, eg: voltage, frequency, load percentage, etc.
<b>VDC</b>	DC Voltage	Battery voltage
<b>%</b>	Percentage	The percentage, eg: Load percentage and battery capacity percentage
<b>OUTPUT</b>	Output	It indicates information for output.
<b>INPUT</b>	Input	It indicates information for input.
<b>LOAD</b>	Load	It indicates information for load.
<b>BATTERY</b>	Battery	It indicates information for battery.
	Load level	It indicates the load level. Load border will flash if the load is overload.
	Battery level	It indicates the battery capacity. Battery border will flash if the battery is low.
	Warning/Fault	It indicates warnings or UPS Fault . If it is a warning, the icon will flash; if it is a fault, the icon will be lighted constantly.

## 4.2 Operating UPS

**Notice:** Please switch off the connected loads first before turning on the UPS, and switch on the loads one by one after the UPS is turned on. Switch off all of the connected loads before turning off the UPS.

**Notice:** Power on for the first time

1. Close the magnetothermic switch located upstream of the UPS.
2. Close the input and output switches and insert the battery fuses (if any) located on the back of the UPS's backpack.

### 4.2.1 Turning on UPS with mains

Check that all connections are correct. Check the breaker of external battery pack is in "ON" position.

Set input breaker in "ON" position. At this time the fan begins to rotate. By pressing  button continuously for more than 2 second, the buzzer will beep once, UPS starts to turn on.

A few seconds later, the UPS turns into Line mode. If the mains power is abnormal, the UPS will transfer to Battery mode without output interruption of the UPS.

### 4.2.2 Turning on UPS without mains

Check that all connections are correct. Check the breaker of external battery pack is in "ON" position.

By pressing  button continuously for more than 2s, the buzzer will beep once, UPS starts to turn on.

A few seconds later, the UPS turns into Battery mode. If the mains power comes back, the UPS will transfer to Line mode without output interruption of the UPS.

### 4.2.3 Turning off UPS with mains

To turn off the inverter of UPS press  button continuously for more than 3s and the buzzer beep once.

The UPS will turn into standby mode.

Cut off the mains power supply.

A few seconds later, LCD display shuts down.

#### **4.2.4 Turning off UPS without mains**

To power off the UPS press  button continuously for more than 3s, and the buzzer beep once. The UPS will cut off the output.

A few seconds later, LCD shuts down and no voltage is available from the UPS output.

#### **4.2.5 Transfer to Bypass**

To transfer the UPS in internal bypass mode, press on/off button and test button at the same time for more than 4 seconds.

To transfer the UPS back to normal mode, press on/off button and test button at the same time for more than 4 seconds.

#### **4.2.6 Transfer to maintenance Bypass**

To transfer the UPS in maintenance bypass mode, switch on the maintenance switch. And then the UPS will transfer to maintenance bypass mode. Switch off the input and output switch before doing maintenance on the UPS.

To transfer the UPS back to normal mode, switch on the input and output switch and then switch off the maintenance switch. Then turn on the UPS following “Turning on UPS” steps.

#### **4.2.7 Transfer to manual Bypass**

Press the on/off button and function button continuously for 4s, the UPS will transfer to manual bypass mode.

If execute manual bypass operation when the UPS is working on ECO mode, the UPS will transfer to bypass output mode. If press the on/off button again to clear manual bypass, the UPS will not transfer back to ECO mode and will stays in bypass output mode.

Only when ups working in line-on mode before executing manual bypass operation, UPS will auto restart to line mode after clearing the manual bypass operation.



## 4.3 Configuration

### 4.3.1 UPS parameters

In order to change UPS parameters (Output Voltage, Number of EBM, ....) please use UPS Configuration Tool (download available here: <http://pqsoftware.eaton.com>).

### 4.3.2 Communication ports

On the back of the UPS (see UPS Views), the following communication ports are present: RS232 connector, USB connector, Slot for optional connectivity cards.

#### RS232 or USB communication ports

The RS232 and USB communication ports cannot operate simultaneously.

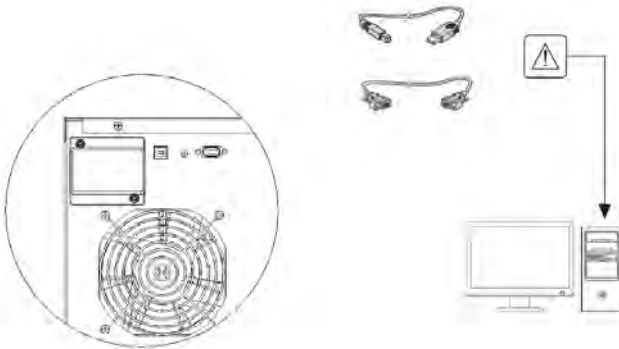

1. Connect the RS232 or USB communication cable to the serial or USB port on the computer.
2. Connect the other end of the communication cable to the RS232 or USB communication port on the UPS.

The **UPS** can now communicate with EATON power management software.

## Connectivity Cards

The UPS is equipped with an expansion slot for optional Connectivity Cards (see figure on right).

It is not necessary to shutdown the UPS before installing a communication card.

1. Remove the slot cover secured by screws.
2. Insert the communication card in the slot.
3. Secure the card cover with the 2 screws

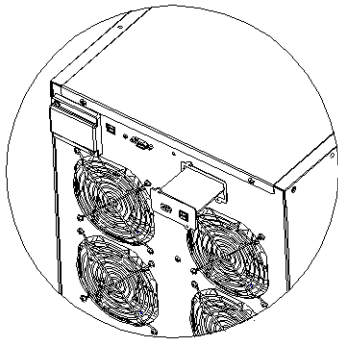

Connectivity cards allow the UPS to communicate in a variety of networking environments and with different types of devices.

- **Network-MS card** - has SNMP and HTTP capabilities as well as monitoring through a Web browser interface; connects to Ethernet network. In addition, a Environmental Monitoring Probe can be attached to obtain humidity, temperature, smoke alarm, and security information.
- **Modbus-MS card** - has connection to Modbus protocol in addition to network management.
- **Relay-MS card** - has isolated dry contact (Form-C) relay outputs for UPS status: Utility failure, Battery low, UPS alarm/OK, or on Bypass.

### 4.3.3 Eaton Intelligent Power Software suite

Each 9E UPS ships with Eaton Intelligent Power Software suite. To begin installing, see the instructions accompanying the Software suite CD.

Eaton Software suite provides up-to-date graphics of UPS power and system data and power flow.

It also gives you a complete record of critical power events, and it notifies you of important UPS or power information.

If there is a power outage and the 9E UPS battery power becomes low, Eaton Software suite can automatically shut down your computer system to protect your data before the UPS shutdown occurs.

## 4.4 Trouble shooting

PROBLEM	POSSIBLE CAUSE	SOLUTION
THE DISPLAY DOES NOT LIGHT UP	INPUT SWITCH OPEN	Close the input switch located on the back of the UPS.
	MAIN CONNECTION CABLE MISSING	Check that the power cable is connected correctly.
	NO MAINS VOLTAGE (BLACKOUT)	Check that the power reaches the UPS
	UPSTREAM THERMAL PROTECTION TRIP	Reset the thermal protection. <u>CAUTION:</u> Check that there is no output overload to the UPS.
THE DISPLAY IS ON BUT THE LOAD IS NOT POWERED	THE UPS IS IN Standby mode	Press the "ON" button on the front panel to power the loads.
THE UPS IS OPERATING FROM THE BATTERY DESPITE THE PRESENCE OF MAINS VOLTAGE	THE INPUT VOLTAGE IS OUTSIDE THE PERMITTED TOLERANCE RANGE FOR MAINS OPERATION	Problem with the mains. Wait until the input mains voltage returns within the tolerance range. The UPS will automatically return to mains operation.

<p>THE BUZZER SOUNDS CONTINUOUSLY AND THE DISPLAY SHOWS ONE OF THE FOLLOWING CODES: <b>A80E, A810, F808</b></p>	<p>THE LOAD APPLIED TO THE UPS IS TOO HIGH</p>	<p>Reduce the load to within the threshold of 100% (or user threshold in the case of code A80E). If the display shows an Fault: remove the load and switch the UPS off and back on again.</p>
<p>THE DISPLAY SHOWS THE FOLLOW CODE: <b>A60D</b></p>	<p>BATTERIES MISSING OR BATTERY BOX MISSING OR NOT CONNECTED</p>	<p>Check that the Battery Box is inserted and connected to the UPS correctly.</p>
<p>THE BUZZER SOUNDS CONTINUOUSLY AND THE DISPLAY SHOWS ONE OF THE FOLLOWING CODES: <b>A004 F004</b></p>	<p>THE TEMPERATURE INSIDE THE UPS IS TOO HIGH</p>	<p>Check that the temperature of the environment in which the UPS is located does not exceed 40°C.</p>
<p>THE BUZZER SOUNDS CONTINUOUSLY AND THE DISPLAY SHOWS ONE OF THE FOLLOWING CODES: <b>F805</b></p>	<p>THERE IS A FAULT ON ONE OR MORE OF THE LOADS POWERED BY THE UPS</p>	<p>Disconnect all the utilities, switch the UPS off and back on again, reconnect the utilities one at a time to identify which one is faulty.</p>
<p>THE BUZZER SOUNDS CONTINUOUSLY AND THE DISPLAY SHOWS ONE OF THE FOLLOWING CODES: <b>F704, F70D,F70C,F302, F303,F305,F300,F301 ,F304, F002</b></p>	<p>THE UPS IS MALFUNCTIONING</p>	<p>If possible, disconnect the power to the load, switch the UPS off and back on again; if the problem occurs again, call the support centre.</p>
<p>THE DISPLAY SHOWS THE CODE: <b>A900</b></p>	<p>THE MAINTENANCE BYPASS FUNCTION IS ACTIVE</p>	<p>To take the UPS out of the maintenance bypass function, open the manual bypass switch on the back of the UPS.</p>

## 4.5 Alarm codes

Using a sophisticated self-diagnosis system, the UPS is able to check its own status and any anomalies and/or faults which may occur during normal operation and display them on the display panel. If there is a problem, the UPS signals the event by showing the code and the type of active alarm on the display.

### Alarms

“Minor” problems which reduce performance or prevent certain functions from being used.

CODE	DESCRIPTION
A007	Fans blocked
A107	Cable connection error
A10A	Unbalanced input voltages (three-phase input)
A806	E.P.O control active
A80E	Overload: load > 105%
A810	Load percentage greater than the user threshold set
A60D	Batteries missing or Battery Box missing or not connected
A802	Low battery
AC20	UPS work in Manual Bypass operation mode

### Faults

Faults are normally preceded by an alarm signal and their scale leads to the power-off of the inverter and the load being powered by the bypass line.

CODE	DESCRIPTION
F002	UPS Fault
F004	Dissipator over temperature
F302 F303	Capacitor bank undervoltage
F300 F301	Capacitor bank overvoltage
F304	Unbalanced capacitor bank
F305	Failed capacitor bank soft start
F70D	Inverter overvoltage
F805	Short circuit

<b>F704</b>	Failed inverter soft start
<b>F70C</b>	Inverter undervoltage
<b>F808</b>	Output overload fault
<b>F811</b>	Negative output power

## 5. Technical data

UPS MODELS		9E6Ki	9E10Ki, 9E10KiXL	9E15Ki	9E20Ki, 9E20KiXL
<b>INPUT</b>					
Nominal voltage	[Vac]	220 - 230 - 240	220 - 230 – 240 / 380 – 400 - 415		
Maximum operating voltage	[Vac]	276	276 / 478		
Nominal frequency	[Hz]	50 - 60			
Nominal current	[A]	26	41 / 16 (42 / 20,5 XL)	62 / 22	82 / 28 (83 / 29,5 XL)
<b>BATTERY</b>					
Recharge time (standard versions)	[h]	< 8h for 90% of the charge			
Expandability and nominal voltage of the Battery Box		180Vdc	240Vdc	240 + 240Vdc	240 + 240Vdc
Charging current (for XL versions only)		Not applicable	4,4A	5A	5A
<b>OUTPUT</b>					
Nominal voltage	[Vac]	Selectable: 220/230/240			
Frequency	[Hz]	Selectable: 50, 60 or <b>auto sensing</b>			
Nominal power	[VA]	6000	10000	15000	20000
Nominal power	[W]	4800	8000	12000	16000
Overload: 105% < load < 110%	Bypass line available:		activates the bypass		
	after 5 min, then		continues to work		
Overload: 110% < load < 130%	Bypass line not available:		locks after 5 min		
	Bypass line available:		activates the bypass		
Overload: 130% < load < 150%	after 1 min, then		locks after 1 min		
	Bypass line not available:		locks after 1 min		
Overload: 130% < load < 150%	Bypass line available:		activates the bypass		
	after 10 s, then		locks after 10 s		

		Bypass line not available:	locks after 10 s		
Overload load > 150%		Bypass line available: after 100 ms, then	activates the bypass locks after 1 s		
		Bypass line not available:	locks after 1 s		
<b>OTHER</b>					
Leakage current to earth	[mA]	< 8mA			
Ambient temperature	[°C]	0 – 40			
Humidity		< 95% without condensation			
Protection devices		Batteries deep discharge - overcurrent - short circuit - overvoltage - undervoltage - circuit breaker			
Dimensions W x D x H	[mm]	262 x 613x 709		350 x 706 x 818	
Weight	[kg]	68.8	86 (29 XL)	147	160 (48.5 XL)
Operating Temperature		0 °C to 40 °C			
Operating humidity		0-95% no condensing			
Altitude		Up to 1,000 meters above sea level with 10% derating per 1000m			
Storage temperature		-15°C to 60°C without batteries 0~35°C with batteries			

<b>EBM</b>		<b>180VDC 9Ah</b>	<b>240VDC 9Ah</b>
Nominal battery voltage	[Vdc]	180Vdc	240Vdc
Dimensions W x D x H	[mm]	262 x 580 x 709	
Weight	[kg]	105.5	132.4





614-06847-03