



UNI JET

ИБП APC MGE Galaxy 9000 - руководство по установке. Юниджет

Постоянная ссылка на страницу: <https://www.uni-jet.com/catalog/ibp/online-ibp/apc-mge-galaxy-9000/>



MGE™ Galaxy™ 9000

50, 60 Hz
800 – 900 kVA



Installation manual

Single-unit UPS

Modular UPS

Parallel UPS with SSC

Frequency converters

Static Switch Cubicle

1. Characteristics	
1.1 Characteristics common to all cubicles	4
1.2 Rectifier-inverter cubicle	5
1.3 Static Switch Cubicle	5
1.4 Electrical parameters for selecting protective devices	6
1.5 Electrical parameters for determining cable cross-sections	7
2. Installation (to be carried out by qualified personnel only)	
2.1 Handing	10
2.2 Positioning the cubicles	10
2.3 Floor loads (figure 5)	11
2.4 Cubicle layout on false floor or normal floor (figures 6, 7, 8)	11
2.5 Power circuit wiring diagrams	13
2.6 Cubicle mounting and connection	17
2.7 Connection of power circuits	19
2.8 Connection of "Media Contacts 9" standard auxiliary circuits (figure 16)	22
2.9 Connections between cubicles (modular UPSs or parallel UPSs with SSC)	23
2.10 Connections between rectifier-inverter cubicles and external maintenance bypass cubicle ..	26
2.11 Connection of "Media Contacts 15" additional auxiliary circuits (figure 22)	27
2.12 Connection of the battery "Temperature Monitor" (optional)	28
2.13 Connection of the "LED" remote indications unit	30
2.14 Connection of "Tele Monitor" remote control and indication unit (option)	30
2.15 Final installation steps	30
3. Appendix (to be carried out by qualified personnel only)	
3.1 Mains 2 line protection	31
3.2 Cubicle mounting and connection for 2000 kVA Static Switch Cubicle	32
3.3 Details of earthing connections in the various cubicles	35

1. Characteristics

1.1 Characteristics common to all cubicles

MGE™ Galaxy™ 9000 UPS: example of a rectifier-inverter cubicle

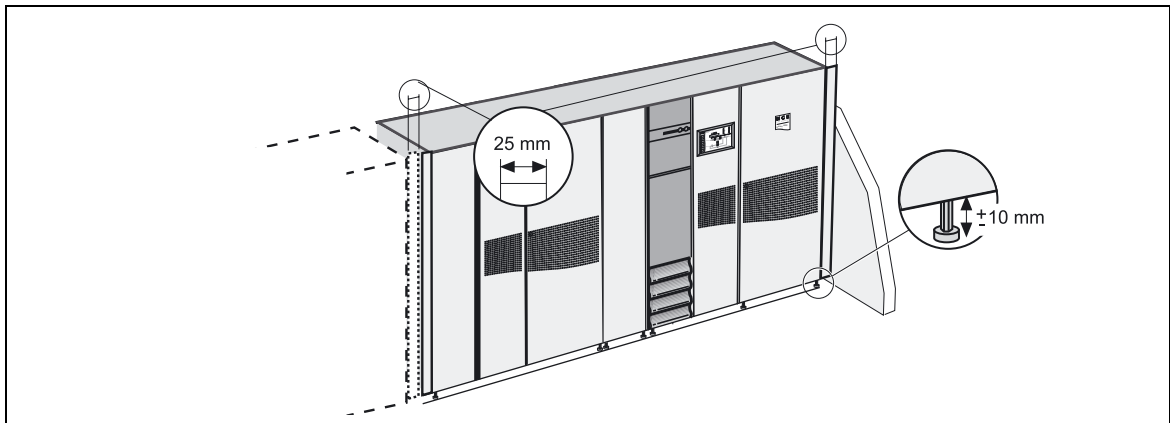
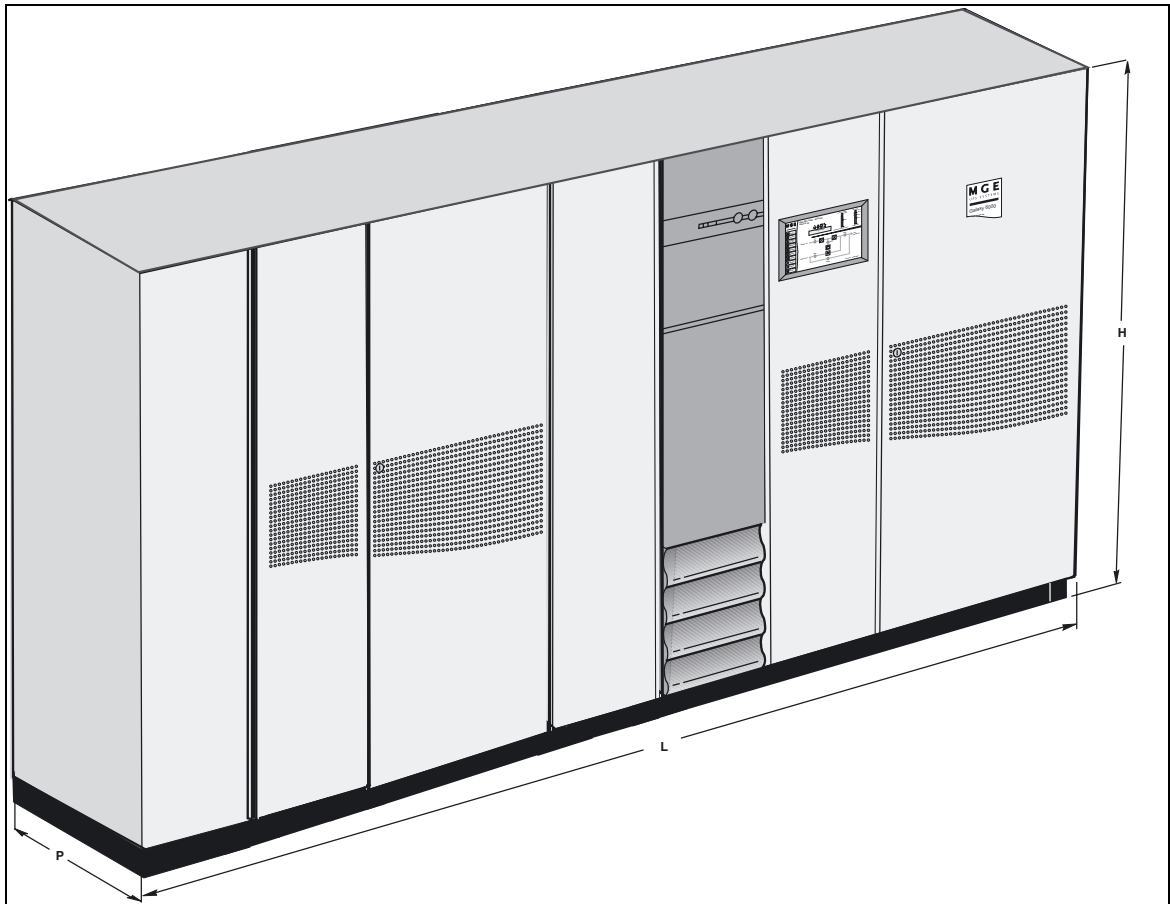

After moving them to their installation location on their pallets, MGE™ Galaxy™ 9000 cubicles can be moved short distances using a forklift or pallet-mover when the front, rear and side base panels are not mounted. The forks can be inserted from all four sides into 100 mm \pm 10 mm high openings;

the unadjusted cubicle height (H) is 1900/2000 mm; after lifting the cubicle, the height can be adjusted \pm 10 mm by screwing in or out the four feet;

the bearing surface corresponds to the area of the four cylindrical foot pads (60 mm diameter) positioned in each corner of the cubicle;

the cubicle depth (D) is 840 mm (800 mm without doors and panels);

operating temperature range for rectifier-inverter, frequency converter or Static Switch Cubicles: 0 °C to 35 °C at rated output (40 °C for a maximum of 8 hours) and 30 °C maximum for overload conditions. Operation outside the specified temperature range will reduce service life;

relative humidity: 95 % maximum;

maximum operating altitude without derating: 1000 m;

connection via the bottom for rectifier-inverter cubicles, or via the top with the addition of an optional duct that can be installed on the right side of the cubicle. The auxiliary and Static Switch Cubicles are designed for connections via the top or bottom.

the connection cables may be run in three ways:

- in a trench running under the cubicles,
- under a false floor,
- on the floor under the cubicles, in the free space equal to the height of the feet; in this case the cables should be run side by side to avoid blocking the flow of air for ventilation.

the intercubicle connection cables are not supplied (except for the wires for auxiliary interconnections);

normally the cubicles do not have to be secured to the floor; the footpads nevertheless have holes with an average depth of 12 mm designed for the fitting of M16 anchor bolts;

the cubicle doors are secured by Ronis locks (key 405).

1.2 Rectifier–inverter cubicle

The parameters given in the table opposite can be used to determine the required rating of a single-unit or modular UPS, a frequency converter, or a parallel UPS with SSC.

Characteristics of rectifier-inverter cubicles

rated inverter output in kVA	cubicle width W in mm (1)	cubicle height H in mm	cubicle depth D in mm	maximum weight in kg	heat losses (2)	
					in kW	in cal./s
800	3600 ±10	2000	840	4260	47	11233
900	3600 ±10	2000	840	4260	47	11233

(1) the width of the vertical side clearance bars (25 mm) on each side must be added to the indicated cubicle width, i.e. 50 mm in all per cubicle. This applies to all cubicle installation cases. Cubicle widths have been rounded off to the nearest cm.

(2) the indicated heat losses are those produced by the unit at full rated load and with the battery float charging. They must be taken into account when dimensioning the air conditioning system. The cubicles are cooled by forced ventilation. The air enters via the doors and grids at the bottom and is discharged via the roof.

1.3 Static Switch Cubicle

Characteristics of Static Switch Cubicles

rated SSC output in kVA	cubicle width W in mm (1)	cubicle height H in mm	cubicle depth D in mm	maximum weight in kg	heat losses (2)	
					in kW	in cal./s
2000	2450 ±10	1900 ±10	840	1710	< 0.5	< 120

(1) 25 mm must be added on each side to the indicated cubicle width, i.e. 50 mm in all per cubicle. This applies to all cubicle installation cases. Cubicle widths have been rounded off to the nearest cm.

(2) the indicated heat losses are those produced by the unit at full rated load when operating on Mains 2. They are not to be taken into account when dimensioning the air conditioning system. The cubicles are cooled by forced ventilation.

Characteristics

1.4 Electrical parameters for selecting protective devices

The parameters given in the table below can be used to determine the required rating of the source side protective circuit breaker on Mains 1 of a single-unit or modular UPS, a frequency converter, or a parallel UPS with SSC.

Important:

It is essential to choose the type of circuit breaker according to its breaking capacity and the prospective short-circuit current at its place of installation.

Note:

For Mains 1 power supply voltages of 380, 400 and 415 V, the Mains 1 current is the same because it is a function of the DC voltage.

Electrical parameters for Mains 1

rated inverter output in kVA	Mains 1 current			
	rated current In for unit:		for 25 % overload (3)	for 50 % overload (3)
	with battery at start of charge cycle (1)	without battery (2)		
800	1555	1329	1819	2183
900	1555	1329	1819	2183

(1) the rated Mains 1 currents (In) have been determined for a rated phase-to-phase voltage of 380 V to 415 V, a battery with a 15 minute backup time (206 cells at 2 V per cell, i.e. 412 V) and at the beginning of its recharge cycle, and full rated load with a power factor of 0.9.

(2) the rated Mains 1 currents (In) have been determined for a minimum float charging voltage of 423 V and full rated load with a power factor of 0.9.

(3) the Mains 1 currents given for an overload of 25 % or 50 % are maximum values. They have been determined for a battery drawing the minimum float charging voltage and a load power factor of 0.9. When choosing the circuit breaker rating, use the "rated current" column and check that the circuit breaker tripping curves are compatible with the values in the overload columns.

The parameters given in the table below can be used to determine the required rating of the source side protective circuit breaker on the Mains 2 line for a single-unit or modular UPS.

Important:

– It is essential to choose the type of circuit breaker according to its breaking capacity and the prospective short-circuit current at its place of installation.

This choice must also be made so as to protect the static switch semiconductors and ensure discrimination with respect to the UPS output fuses (refer to "appendix" chapter).

– For an installation with a Static Switch Cubicle, the Mains 2 currents indicated in the table must be multiplied by the number of parallel-connected rectifier-inverter cubicles required to supply the load power (i.e. without taking redundant rectifier-inverter units into account).

Remark:

If the installation includes a transformer on the Mains 2 input, allow for the inrush current caused by magnetization of the transformer windings.

Electrical parameters for Mains 2 (415 V)

rated inverter output in kVA	Mains 2 current (1)		
	rated current In	for 25 % overload	for 50 % overload
800	1155	1444	1733
900	1299	1624	1949

(1) the Mains 2 currents have been determined for a rated phase-to-phase voltage of 415V, a load power factor of 0.9 and for full rated load as well as overloads of 25 % or 50 %. When choosing the circuit breaker rating, use the "rated current" column and check that the circuit breaker tripping curves are compatible with the data in the overload columns.

For a Mains 2 voltage of 380 V, multiply the currents indicated in this table by 1.09.

For a Mains 2 voltage of 400 V, use the table in another language version of this manual.

1.5 Electrical parameters for determining cable cross-sections

- this table has been drawn up for rated phase-to-phase Mains and load voltages of 415 V. For voltages of 380 V, multiply the currents for Mains 2 and load by 1.09; for voltages of 400 V, use the table in another language version of this manual;
- the current values and cable cross-sections for Mains 1 are given for full rated load with a power factor of 0.9 and a battery consuming its minimum float charging voltage;
- the battery current values and cable cross-sections have been determined for a battery at the end of a charge cycle;
- the current values and cable sections for Mains 2 and load are given for full rated load with a power factor of 0.9.

For frequency converters, the parameters concerning Mains 2 are not applicable.

The load parameters common to all the converters are given in the table below.

For a parallel UPS, the parameters for Mains 2 and load are also provided in the table below.

For a modular UPS, the parameters for Mains 2 and load are also provided in the table below.

Parameters for single-unit UPS cables

Copper conductors

rated inverter output in kVA	line currents absorbed in Amps			cross-sectional area of cables in mm ² (2)		
	Mains 1	415 V Mains 2 and load	battery	Mains 1	415 V Mains 2 and load	battery
	with or without battery (1)			with or without battery (1)		
800	1455	1155	2274	4 x 240	4 x 185	3 x 240
900	1455	1299	2274	4 x 240	4 x 240	3 x 240

Aluminium conductors

rated inverter output in kVA	line currents absorbed in Amps			cross-sectional area of cables in mm ² (2)		
	Mains 1	415 V Mains 2 and load	battery	Mains 1	415 V Mains 2 and load	battery
	with or without battery (1)			with or without battery (1)		
800	1455	1155	2274	4 x 400	4 x 300	3 x 400
900	1455	1299	2274	4 x 400	4 x 400	3 x 400

(1) the rated Mains 1 currents (In) have been determined for a minimum float charging voltage of 423 V and full rated load with a power factor of 0.9.

(2) the cable cross-sections are calculated according to permissible temperature rise and allow for line voltage drops over a maximum length of 100 m (AC circuits) or 25 m (DC circuits if cables not provided). For greater lengths, the cross-sections should be chosen to limit voltage drops to 3 % (AC) or 1 % (DC).

Characteristics

The table below serves as an example for an installation comprising up to four frequency converters or four parallel UPSs with a centralised SSC.

- for installations with redundant units, take into account only the units required to supply the load power (e.g. for an installation made up of 3 parallel-connected rectifier-inverter cubicles, one being redundant, only 2 rectifier-inverter cubicles are used to determine Mains 2 and load currents and cable cross-sections);
- this table has been drawn up for rated phase-to-phase Mains 2 and load voltages of 415 V and full rated load with a power factor of 0.9. For voltages of 380 or 400 V, multiply the indicated currents by 1.09 and 1.04 respectively, then modify the cable cross-sections accordingly if necessary.

The cable cross-sections in this table are for the parts illustrated in bold on the following block diagrams (installation examples, figures 1 and 2).

Parameters for Mains 2 and load cables for an installation comprising frequency converters or parallel UPSs with a centralised SSC.

rated inverter output in kVA	number of parallel-connected inverters	total UPS rated output in kVA	Mains 2 or load line current in Amps	cable cross-section (1) in mm ²
800	2	1600	2310	Please consult us*
	3	2400	3465	Please consult us*
	4	3200	4620	Please consult us*
900	2	1800	2598	Please consult us*
	3	2700	3897	Please consult us*
	4	3600	5196	Please consult us*

(1) cable cross-sections are given for copper conductors of the U1000 R02V type (increase by 30 % for aluminium conductors). They are calculated according to permissible temperature rise and allow for line voltage drops over a maximum length of 100 m. For greater lengths, the cross-sections should be chosen to limit voltage drops to 3 %.

* NF C 15-100 authorizes a maximum of 4 cables per phase.

Installation with parallel frequency converters I

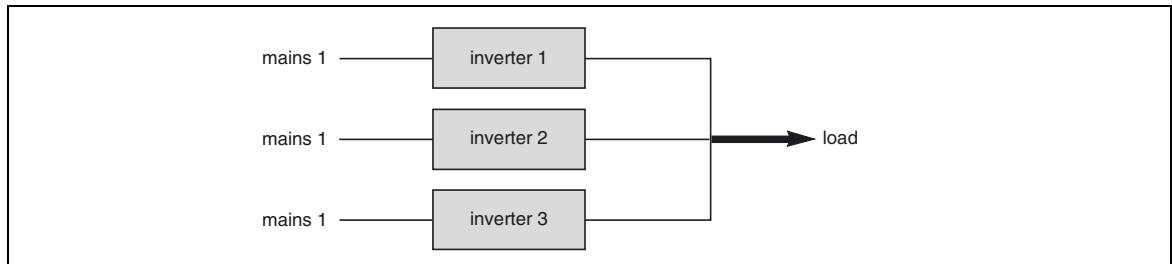

Fig. 1

Installation with parallel UPSs with a centralised SSC

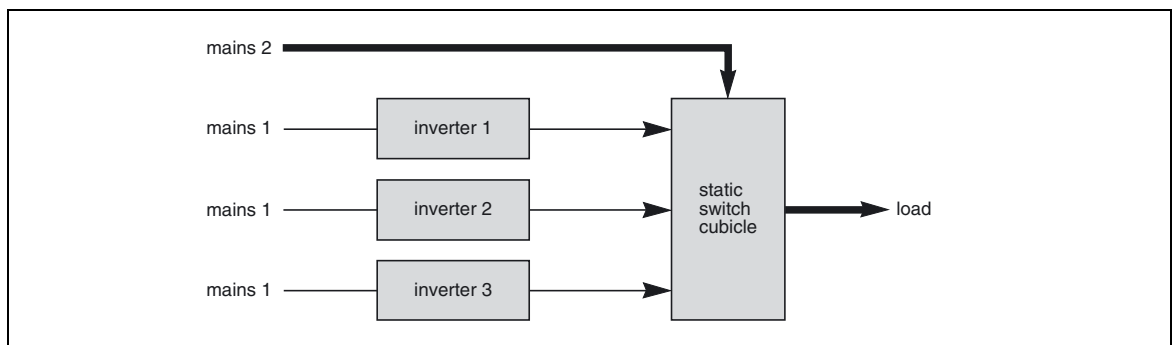

Fig. 2

The table below serves as an example for an installation with up to four modular UPSs with an external maintenance bypass.

- for installations with redundant units, take into account only the units required to supply the load power (e.g. for an installation made up of 3 parallel-connected rectifier-inverter cubicles, one being redundant, only 2 units are used to determine the currents on the maintenance bypass line and the load, and the cross-sectional areas of cables);
- this table has been drawn up for rated phase-to-phase Mains 2 and load voltages of 415 V and full rated load with a power factor of 0.9. For voltages of 380 or 400 V, multiply the indicated currents by 1.09 and 1.04 respectively, then modify the cable cross-sections accordingly if necessary.

The cable cross-sections in this table are for the parts illustrated in bold on the following block diagrams (installation example, figure 3);

- **important.** In an installation with an external maintenance bypass, the power cables **between each UPS and the upstream protection devices must be the same length.** The same holds for the power cables between **each UPS cubicle and the external maintenance bypass.**

rated inverter output in kVA	number of parallel-connected inverters	total UPS rated output in kVA	mains 2 or load line current in Amps	cable cross-section (1) in mm ²
800	2	1600	2310	Please consult us*
	3	2400	3465	Please consult us*
	4	3200	4620	Please consult us*
900	2	1800	2598	Please consult us*
	3	2700	3897	Please consult us*
	4	3600	5196	Please consult us*

(1) cable cross-sections are given for copper conductors of the U1000 R02V type (increase by 30 % for aluminium conductors). They are calculated according to permissible temperature rise and allow for line voltage drops over a maximum length of 100 m. For greater lengths, the cross-sections should be chosen to limit voltage drops to 3 %.

* **NF C 15-100 authorizes a maximum of 4 cables per phase.**

Installation comprising modular UPSs with an external maintenance bypass

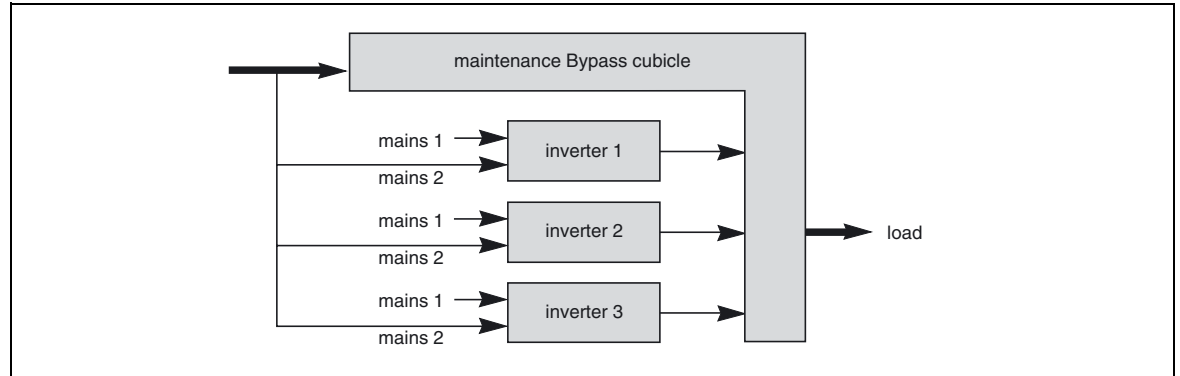

Fig. 3

2. Installation (to be carried out by qualified personnel only)

2.1 Handing

Unpacked cubicles may be moved using a forklift from the front or from the back. Distances must not exceed a few meters.

2.2 Positioning the cubicles

- prior to moving the cubicles to their final position, remove the packing material and withdraw the base panels from the space on the side created by the spacing uprights. The panels will be installed at the end of the installation procedure;
- spacing uprights on the sides of the cubicles create a 50 mm clearance when cubicles are positioned next to each other, enabling users to open the doors (see figure 4). If a cubicle is installed next to a wall, leave additional space so that the cubicle is 50 mm from the wall;
- when the spacing uprights are not required (cubicles are not positioned next to a wall or another cubicle), they may be removed:
 - loosen the four screws securing the upright,
 - lift the upright and pull it free,
 - replace the long gold-coloured screws with the black screws supplied in a bag attached to the cable terminals in the cubicle;
 - adjust the height of the feet until the first cubicle is perfectly vertical; adjust the feet of the subsequent cubicles so that the all the doors are perfectly aligned.

Side clearances provided by the spacing uprights

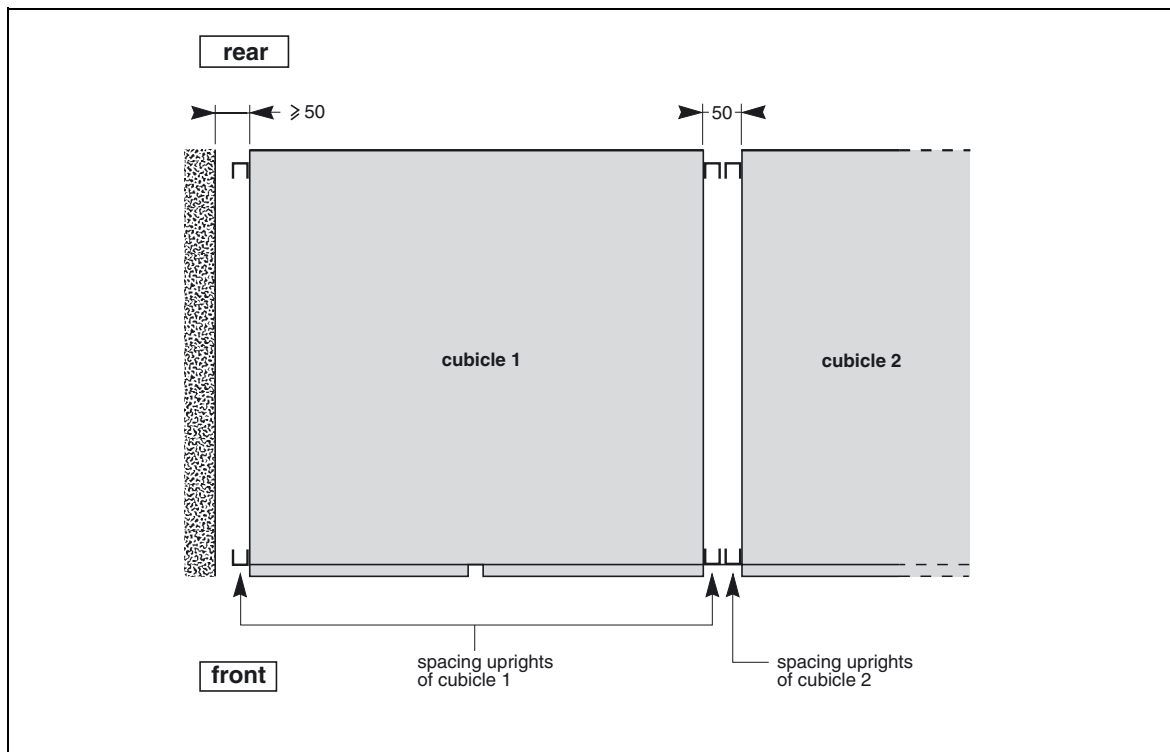

Fig. 4

2.3 Floor loads (figure 5)

- the floor supports the weight of each cubicle via the four 60 mm diameter pads at the bottom of the feet screwed into the corners of the frame;
- the exact locations of the footpads are indicated in the figure;
- normally the cubicles do not have to be secured to the floor; the footpads nevertheless have holes with an average depth of 12 mm designed for the fitting of M16 anchor bolts;
- to determine the stresses applied by the cubicle feet on the floor, divide the cubicle weight (see the first 3 tables of this manual) by the total area of the 4 footpads (110 cm²).

Cubicle footpads

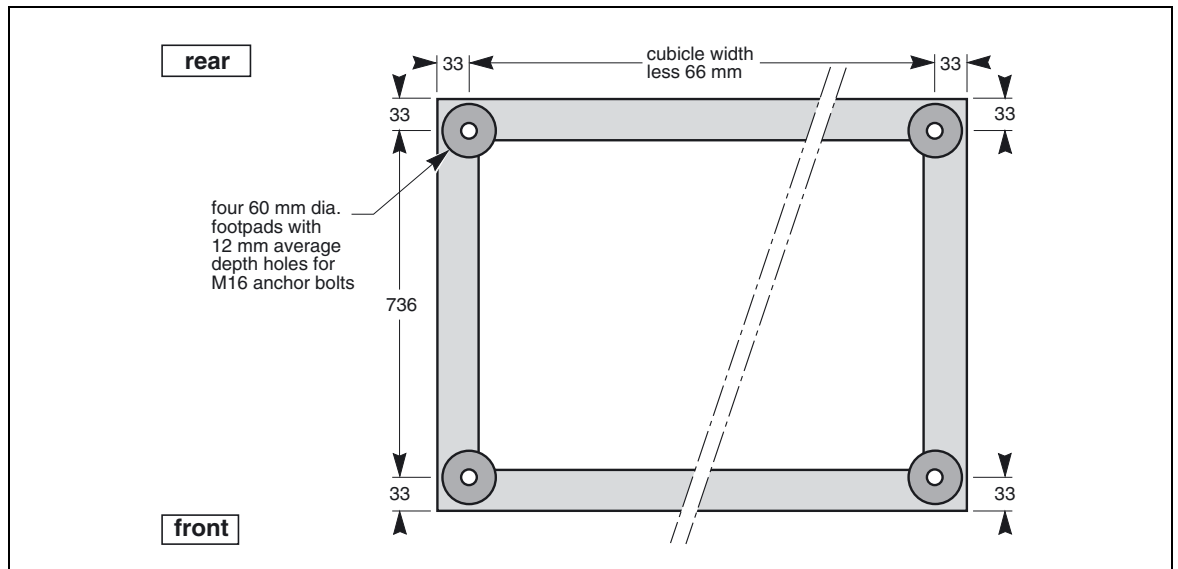

Fig. 5

2.4 Cubicle layout on false floor or normal floor (figures 6, 7, 8)

- the cubicles can be installed directly up against the rear wall;
- an overall clearance of 400 mm must be left above the entire surface of the cubicles for ventilation;
- a side clearance of 25 mm is provided by the vertical bars on the sides of the cubicles to allow door opening. For cubicles mounted side by side, the two adjacent bars ensure an inter-cubicle clearance of 50 mm;
- a minimum clearance of 1000 mm is required in front of the cubicles to allow complete opening of the doors and easy access for maintenance work (replacement of subassemblies);
- for extended battery backup times or high output systems, the UPS may have several battery cubicles (see the table at the end of the previous chapter). If this is the case, install the battery cubicles on the left side of the rectifier-inverter cubicle with the cubicle containing the battery circuit breaker QF1 closest to the rectifier-inverter cubicle (figure 7);
- when an auxiliary cubicle is included in the UPS, it should be installed to the left of the battery cubicle(s);

connection via the bottom

The connection cables may be run in three ways:

- in a cable trench running underneath the front of the cubicles (see trench dimensions and layout in figure 6),
- under a false floor. A cutout must in this case be made in the floor for cable entry (see figure 6 for dimensions),

Installation

Layout for a single-unit UPS with one battery cubicle

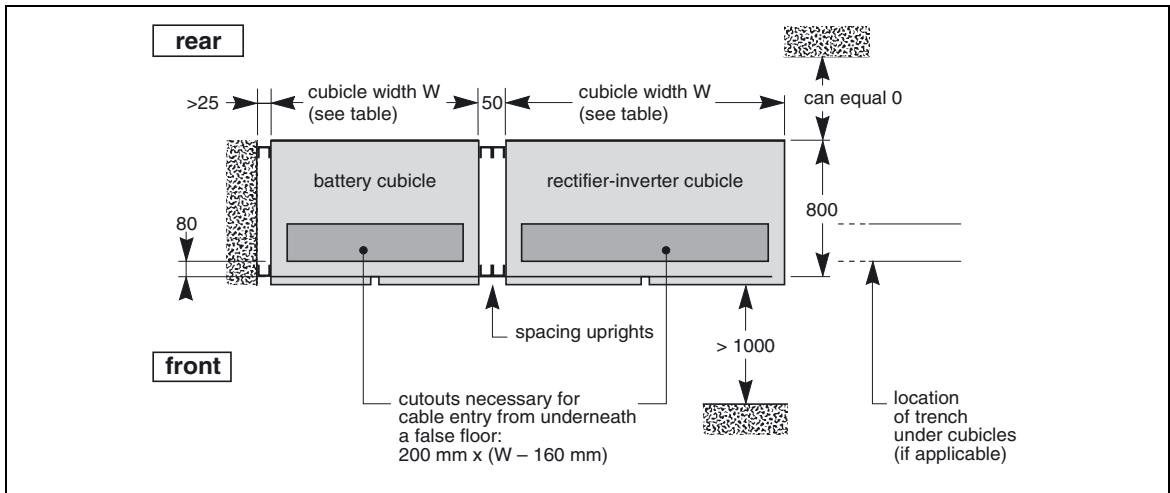

Fig. 6

Layout for a single-unit UPS with several battery cubicles

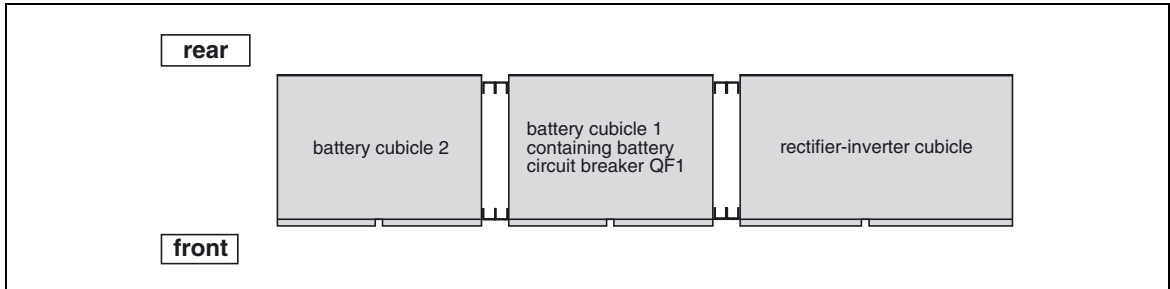

Fig. 7

– on the floor under the cubicles, in the free space equal to the height of the feet. In this case the cables should be run side by side to avoid blocking the flow of air for ventilation. The cables exit from the rear or sides of the cubicles;

connection via the top

- the Static Switch, filter and auxiliary cubicles are designed for connection via the bottom or top,
- for the rectifier-inverter cubicles, a special 400 mm wide connection duct must be added to the right of the cubicle to allow connection via the top.

Layout for an installation with two parallel UPSs and a centralised SSC

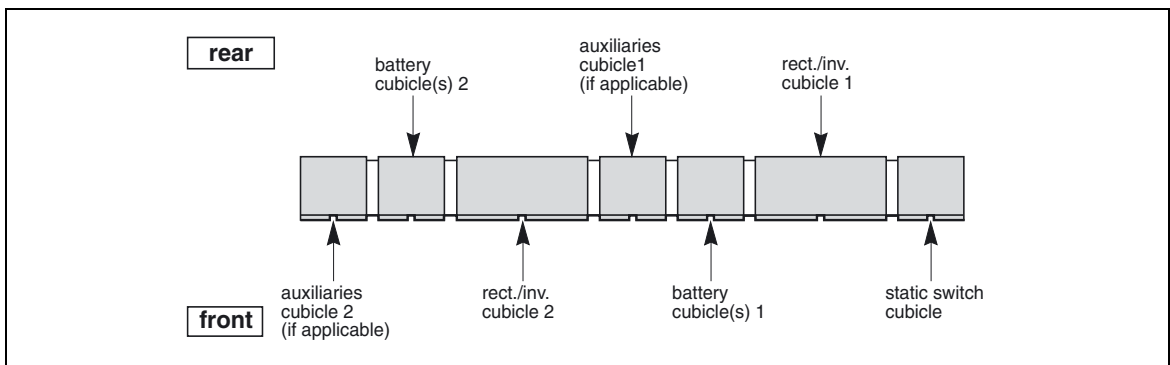

Fig. 8

2.5 Power circuit wiring diagrams

The single-wire diagrams for typical UPS installations are given in figures 9 to 15. The heavy lines represent the cables that must be connected

(see the table in the previous chapter for the required cross-sectional areas of the cables).

Note:

- for frequency converters, the input and output frequencies may be different (50 or 60 Hz);
- for frequency converters without batteries, ignore the battery cubicles and the + and - cables shown in the diagram.

Special case:

The UPSs can be optionally supplied with the neutral conductor not interrupted by switches Q4S, Q3BP and Q5N.

Diagram for a single-unit or single modular UPS with common Mains 1 and 2

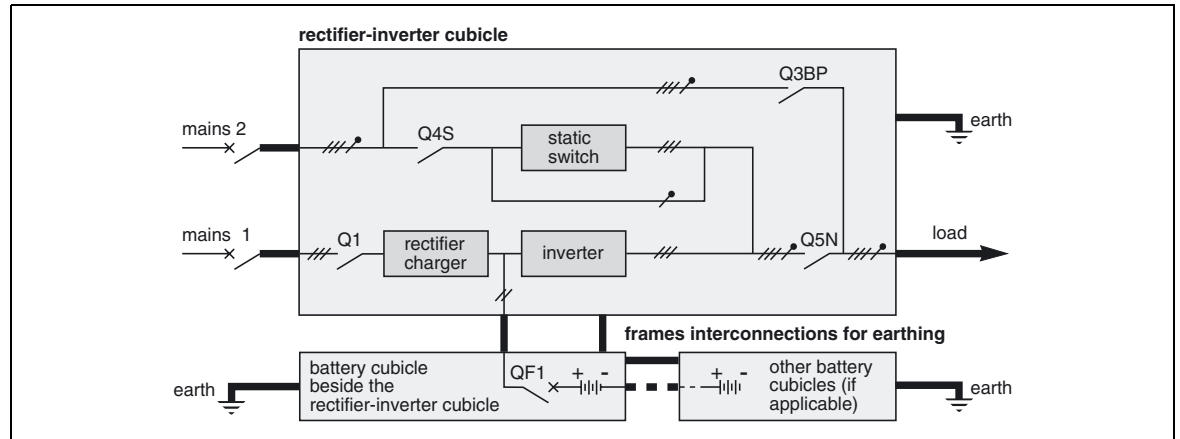

Fig. 9

Diagram for a single-unit or single modular UPS with common Mains 1 and 2

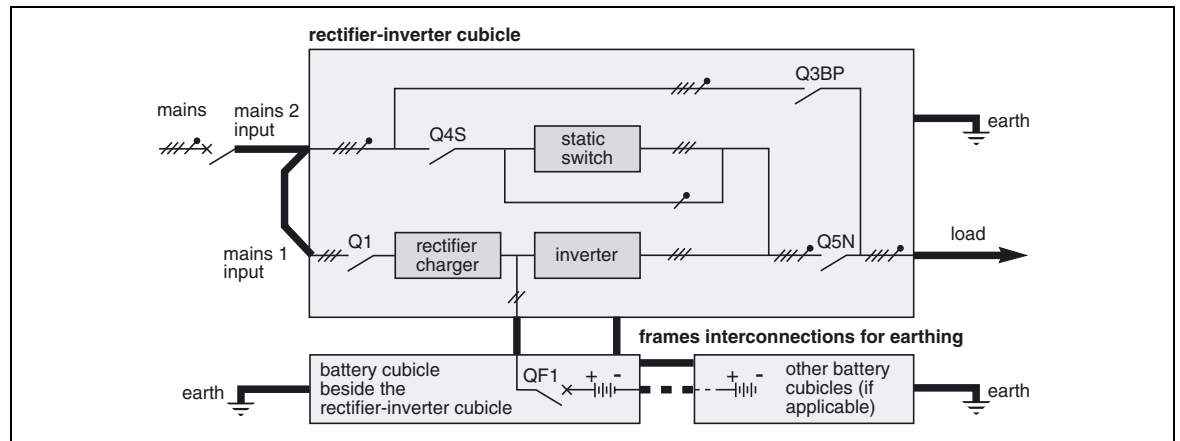

Fig. 10

Diagram for a frequency converter with batteries

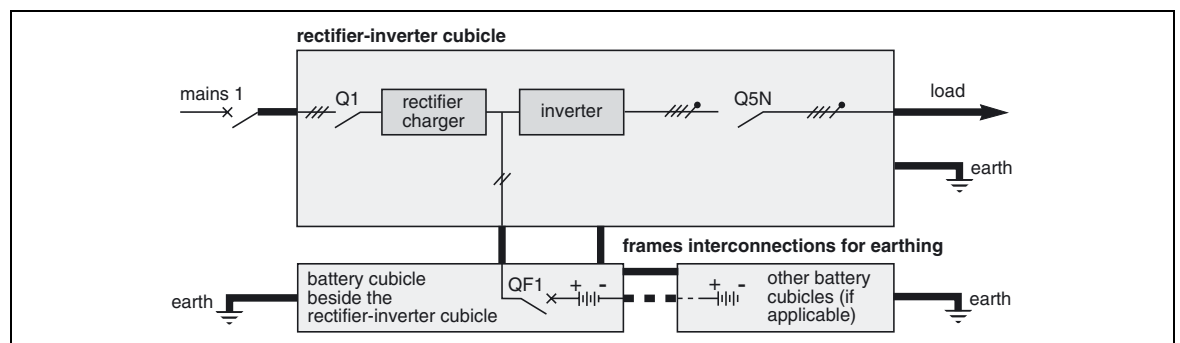

Fig. 11

Installation

Diagram for a frequency converter without batteries

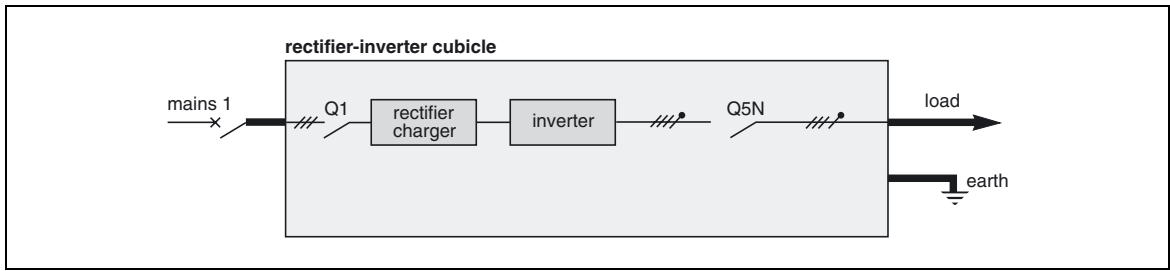

Fig. 12

Example of a 2 parallel UPS rectifier-inverters with SSC

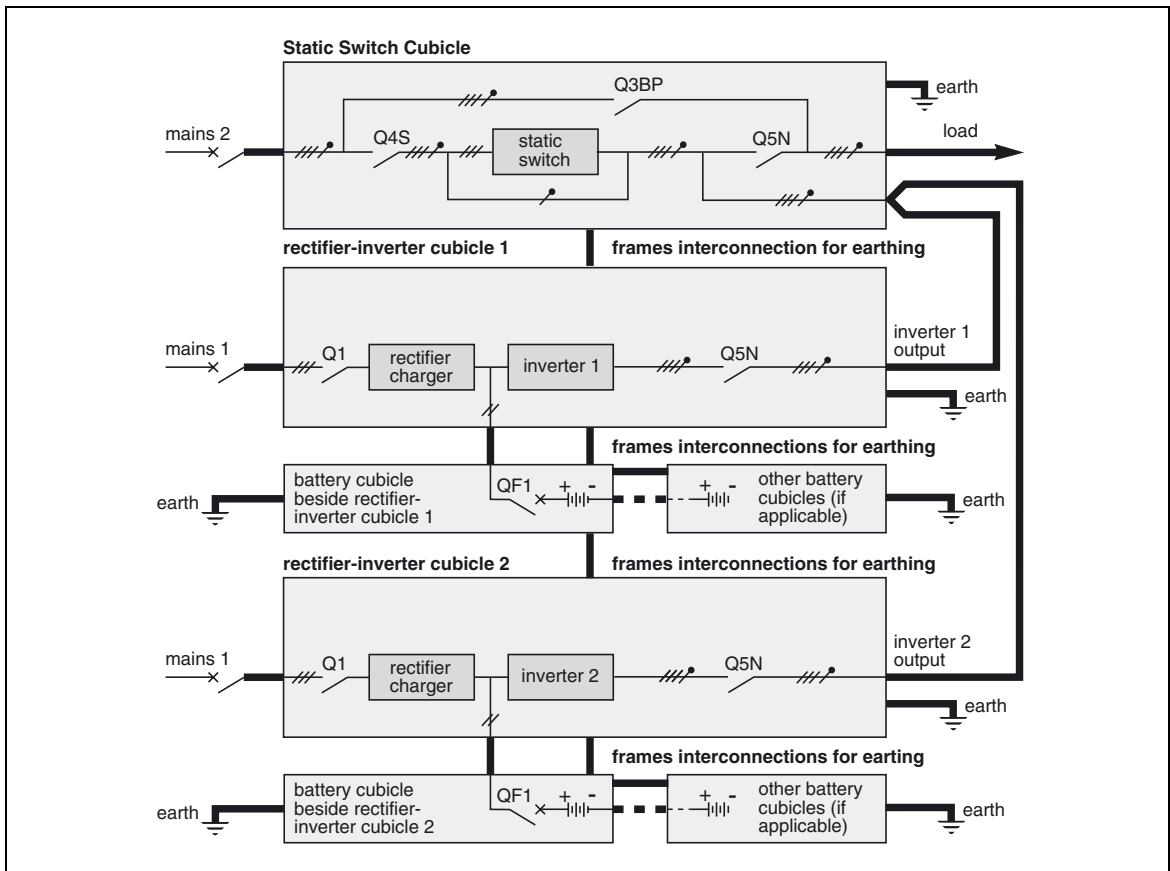

Fig. 13

Note:

Both the rectifier-inverter cubicles and the Static Switch Cubicle can be supplied from a common Mains, in which case there is only one upstream circuit breaker (same as the case of a single-unit UPS with a common Mains 1 and 2).

Example of 2 multi-bypass modular UPS cubicles for redundancy

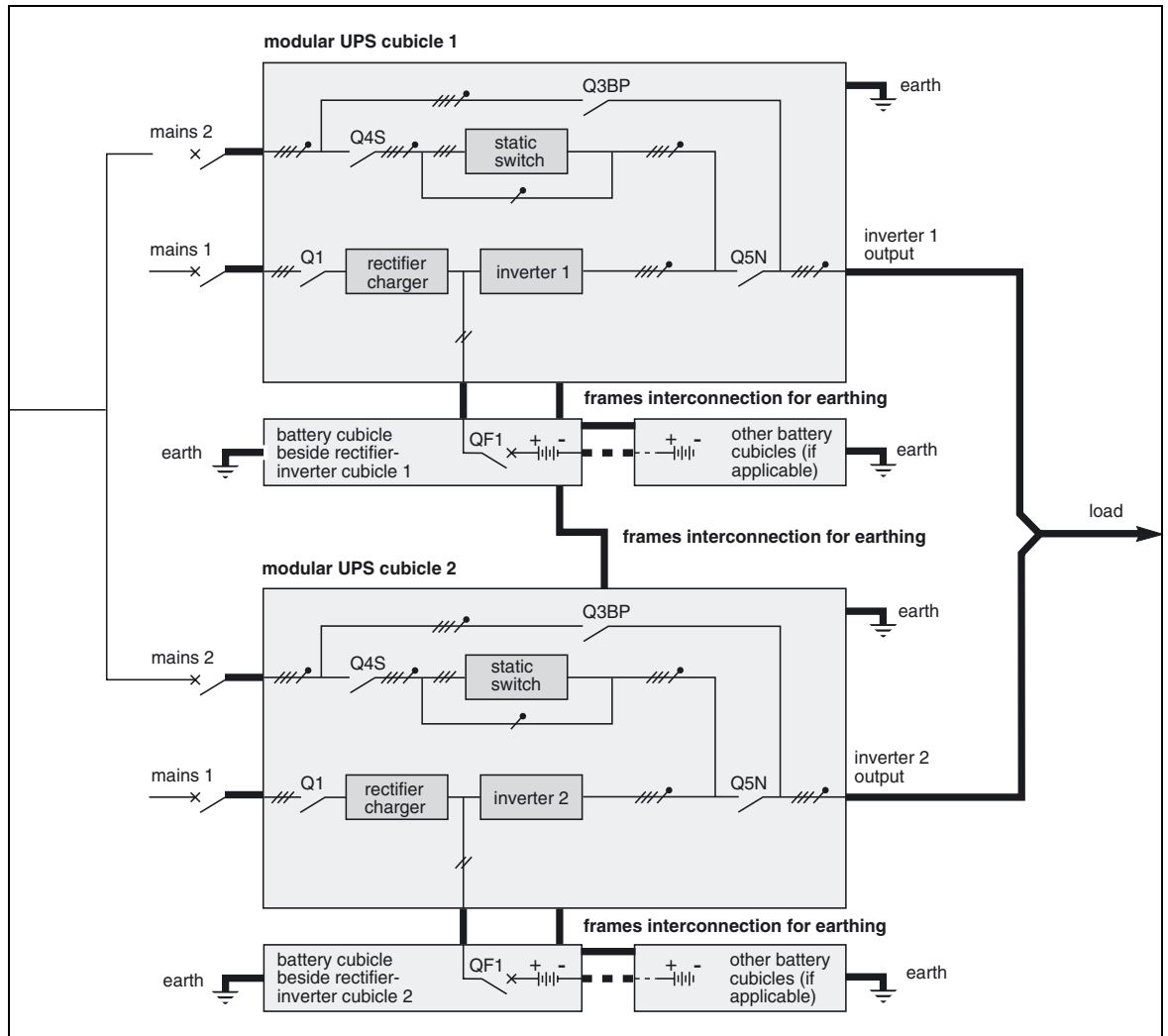

Fig. 14

Installation

Example of an installation comprising three modular UPSs with an external maintenance bypass

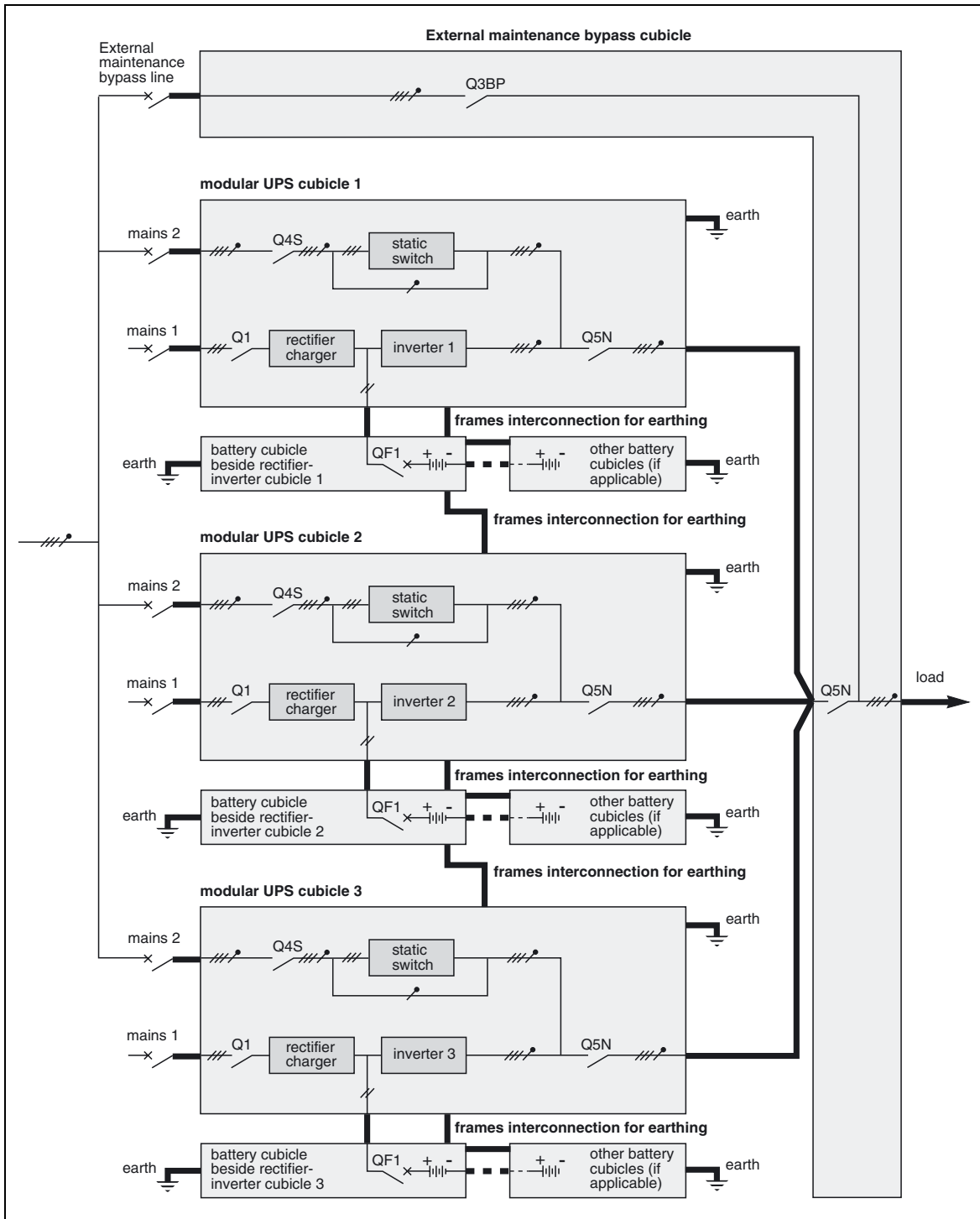

Fig. 15

Important. The power cables between each UPS and the upstream protection devices must be the same length. The same holds for the power cables between each UPS cubicle and the external maintenance bypass.

2.6 Cubicle mounting and connection

Mounting of the left and right cubicles

Gusset plates have been fitted to the top corners on all four sides of the cubicles to provide reinforcement for transportation.

- prior to joining the two cubicles, remove the rear gusset from the right side of the left cubicle;
- move the cubicles to their operating location;
- adjust the front foot pads so that the cubicles are vertical and their doors aligned;
- remove the top panel on the left side of the right cubicle for access to the side gussets (see figure opposite);
- remove the rear double gusset on the right cubicle, turn it around and bolt the two cubicles together.

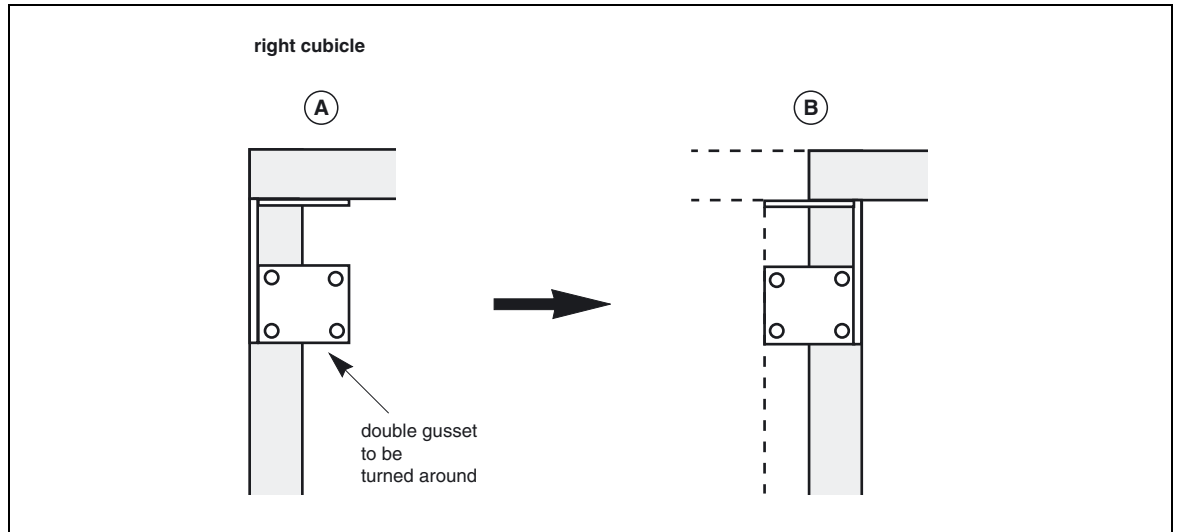

Installation

Internal connections between cubicles

- removal of inverter leg no.6 is recommended prior to bolting fish-plates L+ and L-;
- first remove the two fuses and the two cables connected to the leg;
- then pull the leg out;
- bolt fish-plates L+ and L-;
- refit inverter leg no 6;
- intended only for transportation, the front gussets do not need to be refitted;
- bolt cables L1, L2, L3 and N (4 x 2) coming from the left cubicle to the bars in the right cubicle (see figure opposite);
- connect the earth strap to the front uprights of both cubicles;
- connect the connectors marked XF286 to XF2810 on the five ribbon cables coming from the right cubicle to connectors XM286 to XM2810 respectively on the interface board located on the right side of the left cubicle;
- connect the connectors marked XFGD01 to XFGD05 (XFGD01 to XFGD05 and XMGD06 for parallel UPSs) on the control wires coming from the left cubicle to connectors XMGD01 to XMGD05 (XMGD01 to XMGD05 and XFGD06 for parallel UPSs).

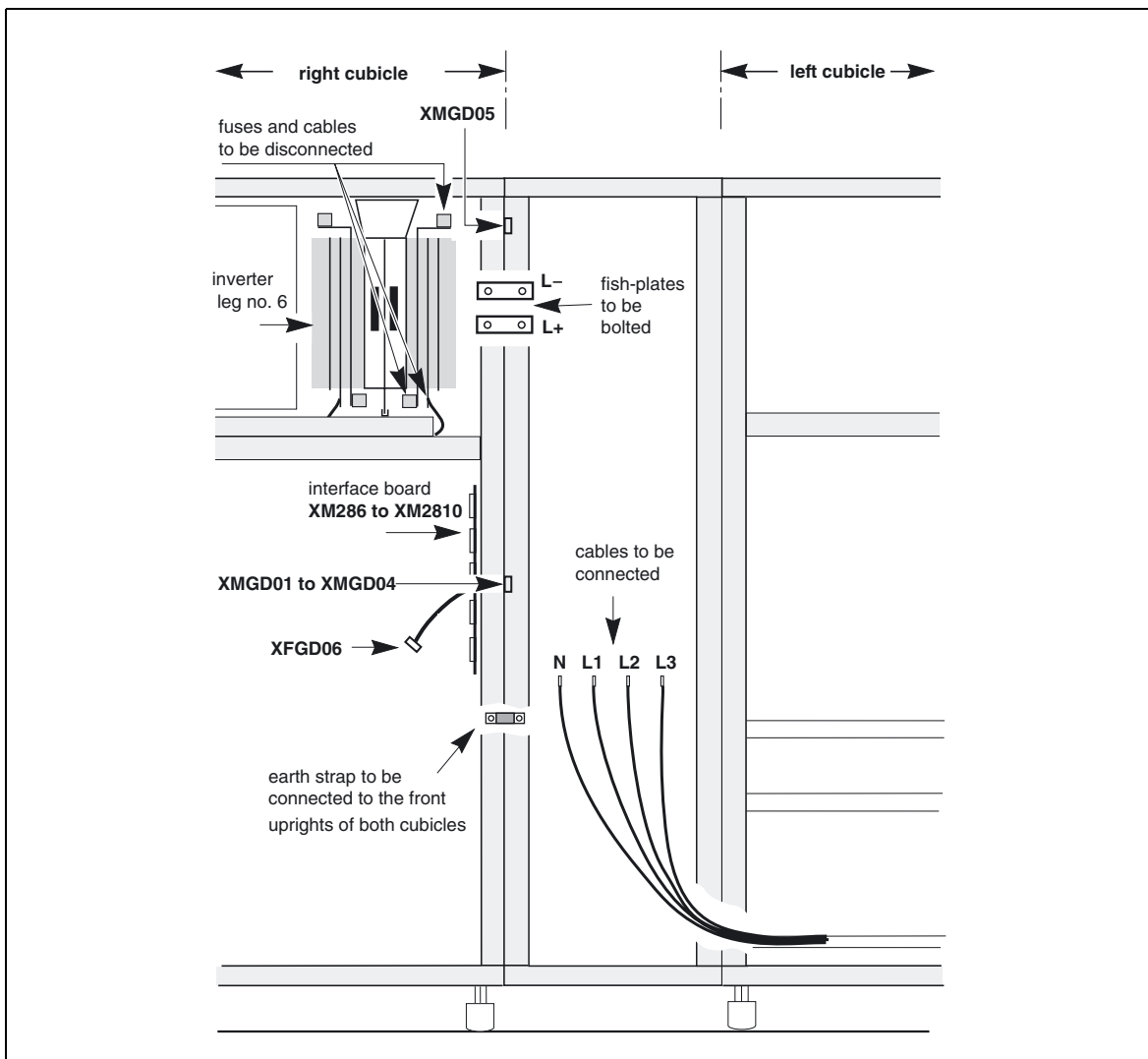

2.7 Connection of power circuits

Before making connections, check that switches Q1, Q4S, Q3BP and Q5N are in the "open" position (toggle opposite the "O" mark).

General:

- in the case of parallel-connected rectifier-inverter cubicles with SSC, switches Q4S and Q3BP are not included and mains 2 is connected to the Static Switch Cubicle. The other connections are the same;
- for modular UPSs with an external maintenance bypass, switch Q3BP must be locked open;
- the power cables for the connections between cubicles are not supplied;
- open the doors and remove the lower terminal shields (secured by screws to the cubicle chassis) of the rectifier-inverter and Static Switch Cubicles;
- connect the cables shown in heavy lines in the wiring diagrams shown previously to the terminals specified in the figures below;
- each cubicle must be earthed;
- the routing of the power cables is shown in the figures;
- the auxiliary wiring is routed in troughs located nearby (not shown in the drawings);
- outside the cubicles, separate the auxiliary wiring from the power cables;
- all the cubicles must be interconnected for earthing, forming a mesh which is itself connected to the building structure and earthing electrode;
- the connection drawings hereafter show the cubicles with doors open and terminal shields removed.

Left cubicle of single-unit or parallel UPS with SSC

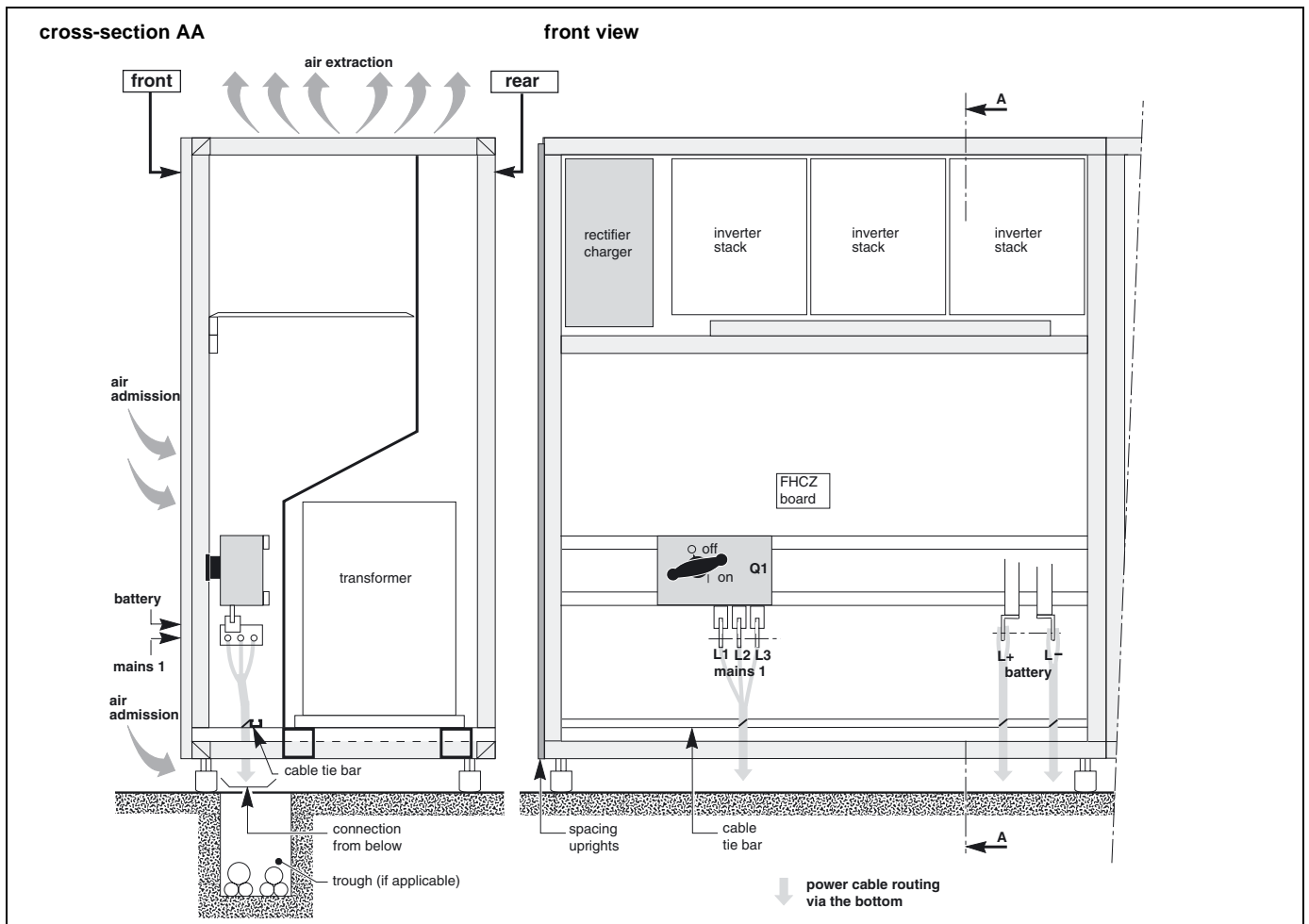

Cables connected by lugs to 100 x 8 mm copper terminals and 13 mm diameter holes.

Height of connections relative to floor:

- mains 1: 450 mm;
- battery: 480 mm.

Installation

Right cubicle of single-unit UPS

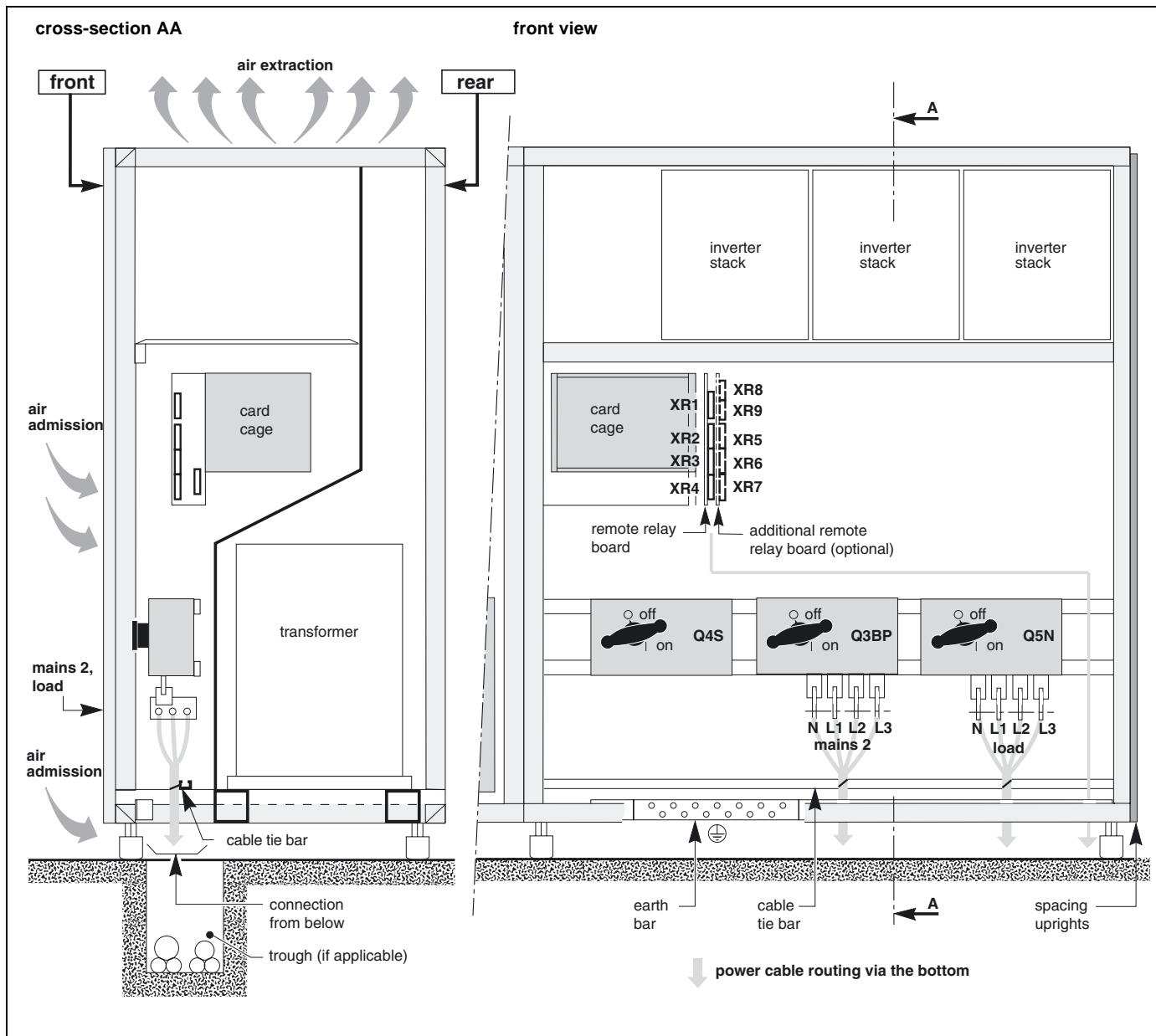

Cables connected by lugs to 100 x 8 mm copper terminals and 13 mm diameter holes.

Height of connections relative to floor:

- mains 2 and load: 430 mm;
- remote relay board: 1030 mm.

Right cubicle of a parallel UPS with SSC

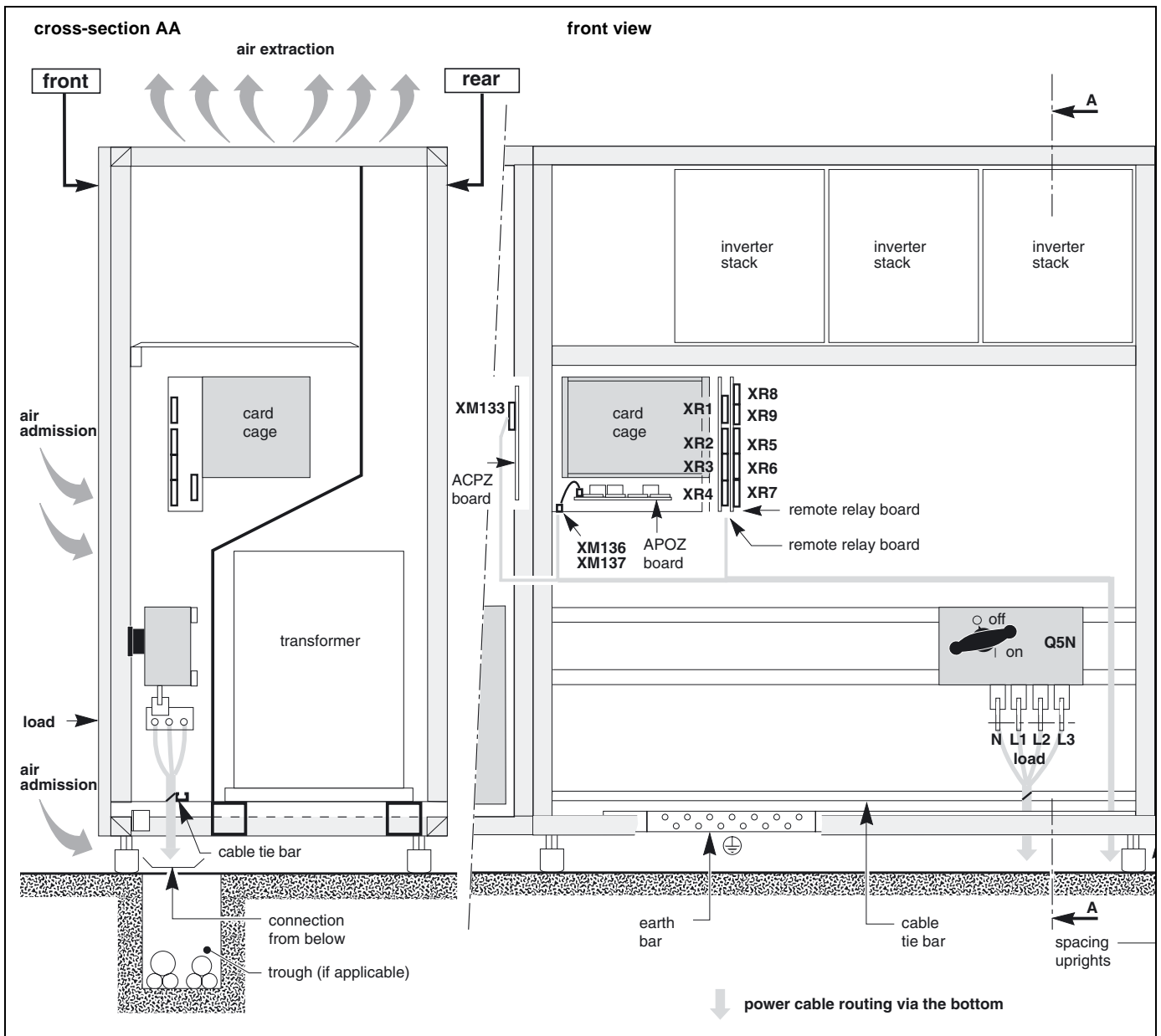

Cables connected by lugs to 100 x 10 mm copper terminals and 14 mm diameter holes.

Height of connections relative to floor:

- load: 410 mm;
- remote relay board: 1030 mm.

Installation

2.8 Connection of "Media Contacts 9" standard auxiliary circuits (figure 16)

The standard auxiliary circuits of the rectifier-inverter and Static Switch Cubicles are connected to the remote relay board by 4 connectors (see the location of this board in the figures of the previous section).

- recommended cable cross-section: 1 mm² (use a shielded cable to connect the battery cell);
- the male connectors that fit the female connectors on the board (XR1 to XR4) are supplied;
- the contacts are volt-free and are shown in the diagram under the following conditions: UPS on, contact at rest;
- contact breaking capacity: 250 V, 5 A.

Connection of auxiliary circuits on the remote relay board

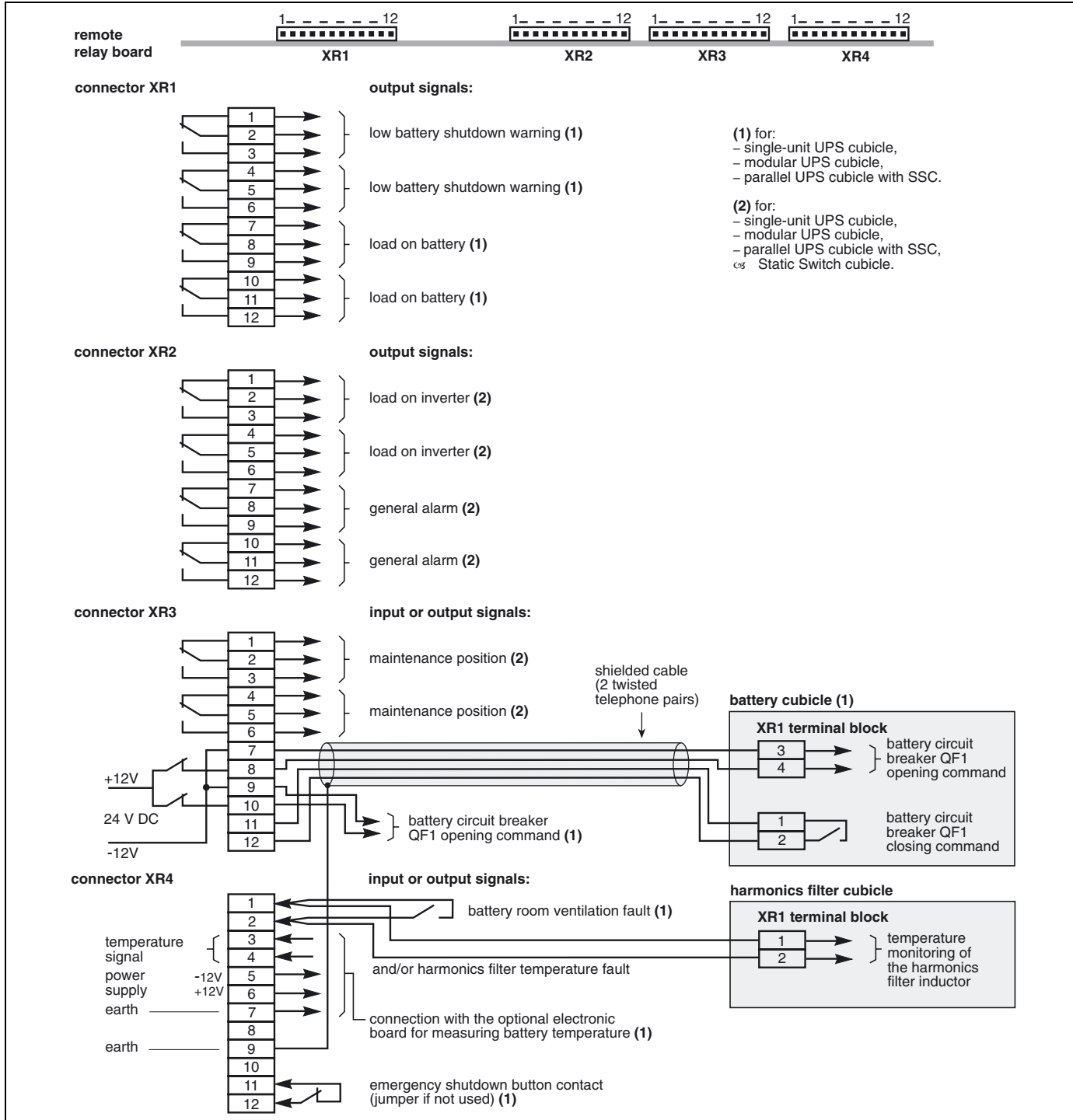

Fig. 16

Connection to battery circuit breaker QF1

Connect the cable from connector XR3 (pins 7 to 12) of the rectifier-inverter cubicle remote relay board to connector XR1 of the battery cubicle containing battery circuit breaker QF1.

Emergency shutdown

The UPS emergency shutdown function is generally wired to a "mushroom-head" type emergency off button.

Important:

In the case of a complex installation with a number of units, there should only be one emergency shutdown pushbutton and this pushbutton must interrupt all the active conductors of all the units.

For the same reason, it is essential for the pushbutton to open the upstream mains 1, mains 2, and external maintenance bypass line protective circuit breakers.

Each type of unit (UPS and Static Switch Cubicle) must have an independent, volt-free contact connected to the emergency shutdown pushbutton. This pushbutton must therefore have as many contacts as there are units in the installation, as well as the contact or contacts required to open the upstream mains 1 and 2 protective circuit breakers. The emergency shutdown pushbutton turns off the rectifier-chargers and inverters and opens the battery circuit breakers. The emergency shutdown signal will be cleared when the emergency shutdown pushbutton contact has been reset.

The emergency shutdown pushbutton should not be connected to the Static Switch Cubicle since the pushbutton opens the circuit breaker protecting the upstream circuit (mains 2) and the Static Switch Cubicle is therefore no longer powered (inverters off and mains 2 down).

2.9 Connections between cubicles (modular UPSs or parallel UPSs with SSC)

On modular UPSs, interconnections are made on the APOZ (figure 17) and MISI (figures 19 to 21) boards in the UPS cubicles (see the layout of the boards in the figures in the previous section).

For parallel UPSs with a centralised SSC, interconnections are made on the APOZ boards in the UPS cubicles (figure 17) and the ACPZ boards (see the layout of the boards in the figures in the previous section) in the SSC (figure 18).

Connections between APOZ boards

- these connections are made using the ribbon cables supplied;
- the purpose of the connection is to make a loop: connector XM137 of the APOZ board of one UPS being connected to connector XM136 of the APOZ board of the next UPS and so on until the first board is returned to.

Important:

Outside the cubicles, **group the APOZ** inter-board and ACPZ or MISI inter-board connections with the inter-cubicle auxiliary connections, and **separate this assembly from the power cables**.

Connections between rectifier-inverter cubicles

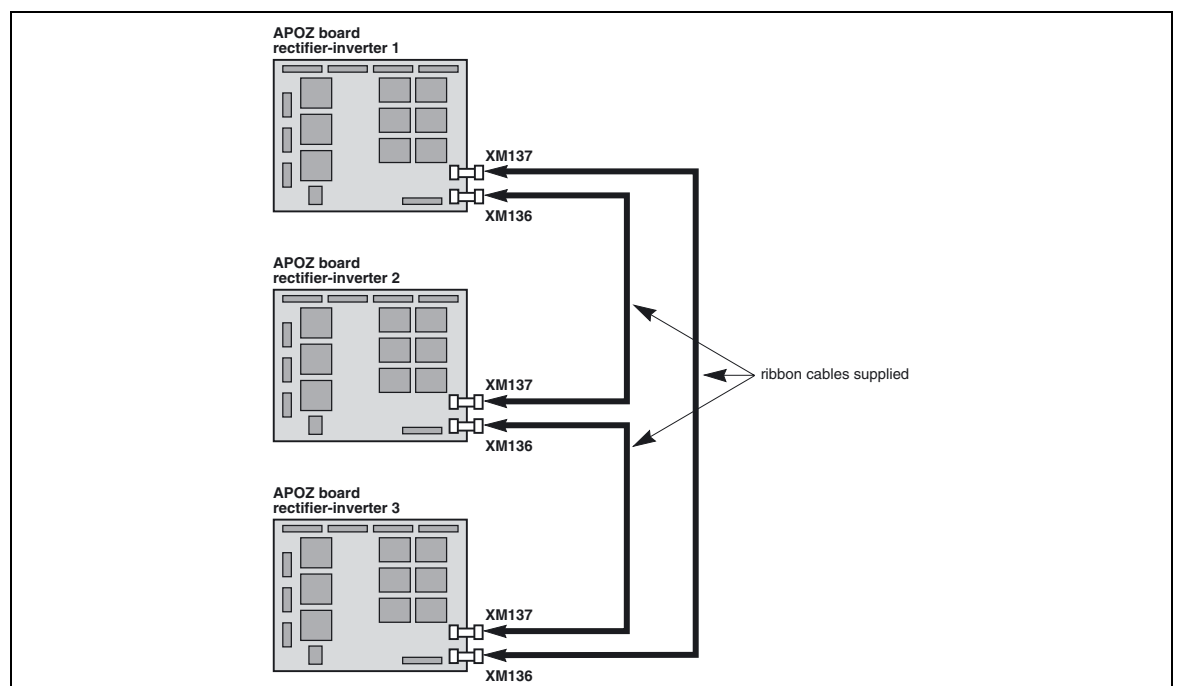

Fig. 17

Installation

Connections between ACPZ boards (frequency converters or parallel UPSs with SSC)

- these connections are made through the special cables supplied;
- these connections only concern installations with a Static Switch Cubicle and should be made in addition to the connections between rectifier-inverter cubicles described previously;
- the ribbon cable from connector XM133 of the ACPZ board of one rectifier-inverter cubicle is connected to one of the connectors XM127 to XM132 of the ACPZ board of the Static Switch Cubicle.

Important:

Outside the cubicles, **group the APOZ inter-board and ACPZ inter-board connections with the inter-cubicle auxiliary connections, and separate this assembly from the power cables.**

Connections between each rectifier-inverter cubicle and the Static Switch Cubicle (example of 3 parallel UPS rectifier-inverters with SSC)

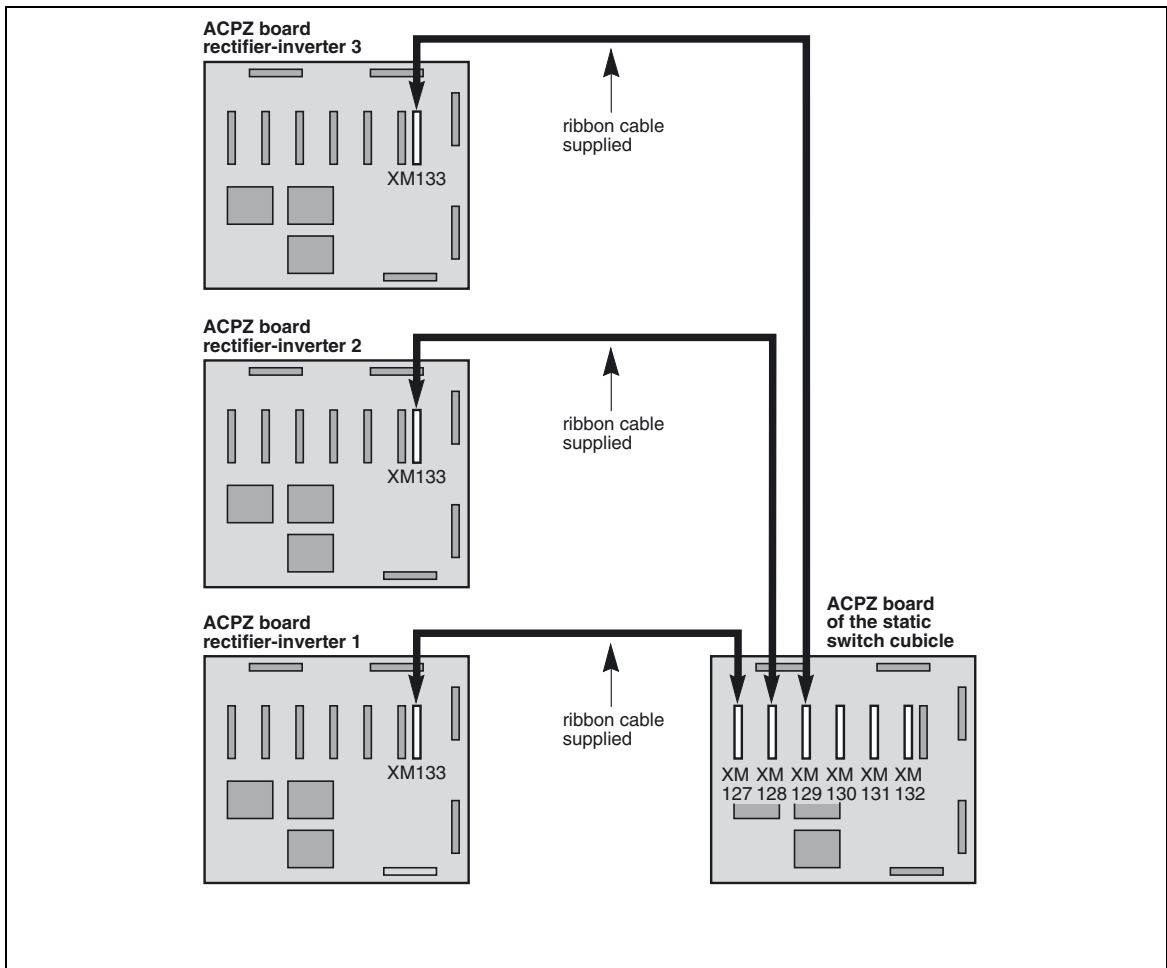

Fig. 18

Connections between MISI boards (modular UPSs)

See figures 19 to 21.

- these connections are made using the special cables (A) supplied;
- connectors XM5, XM6 and XM7 on the MISI board are used to transmit signals;
- connectors XM10, XM11 and XM12 on the MISI board are used to receive signals;
- connector XM5 is associated with connector XM10 for communication with a second UPS unit; similarly, XM6 is associated with connector XM11 for communication with a third UPS unit and XM7 is associated with connector XM12 for communication with a fourth UPS unit;
- situation with two modular UPS units: see figure 19;
- situation with three modular UPS units: see figure 20;
- situation with four modular UPS units: see figure 21.

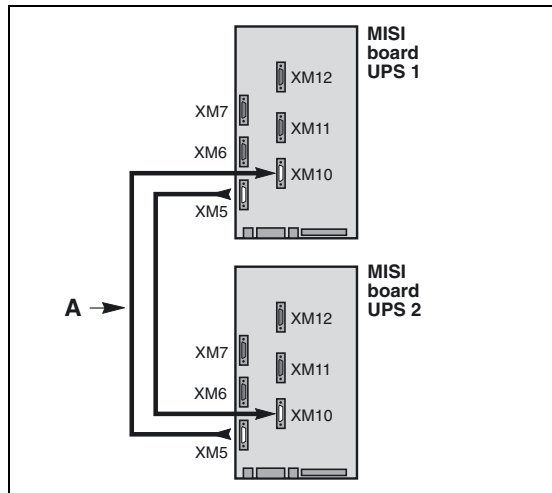

Fig. 19

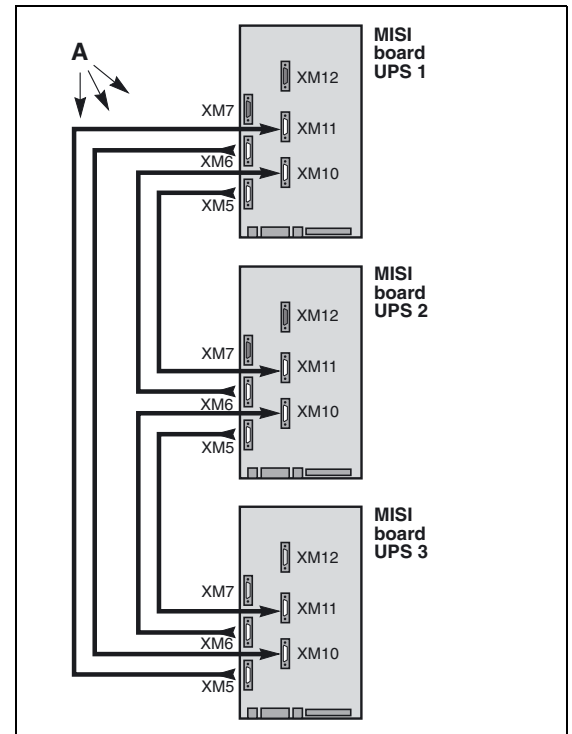

Fig. 20

Installation

Important

Outside the cubicles, **group the cables** between the MISI boards and those between the APOZ boards with the other auxiliary links between cubicles and **separate all these cables from the power cables**.

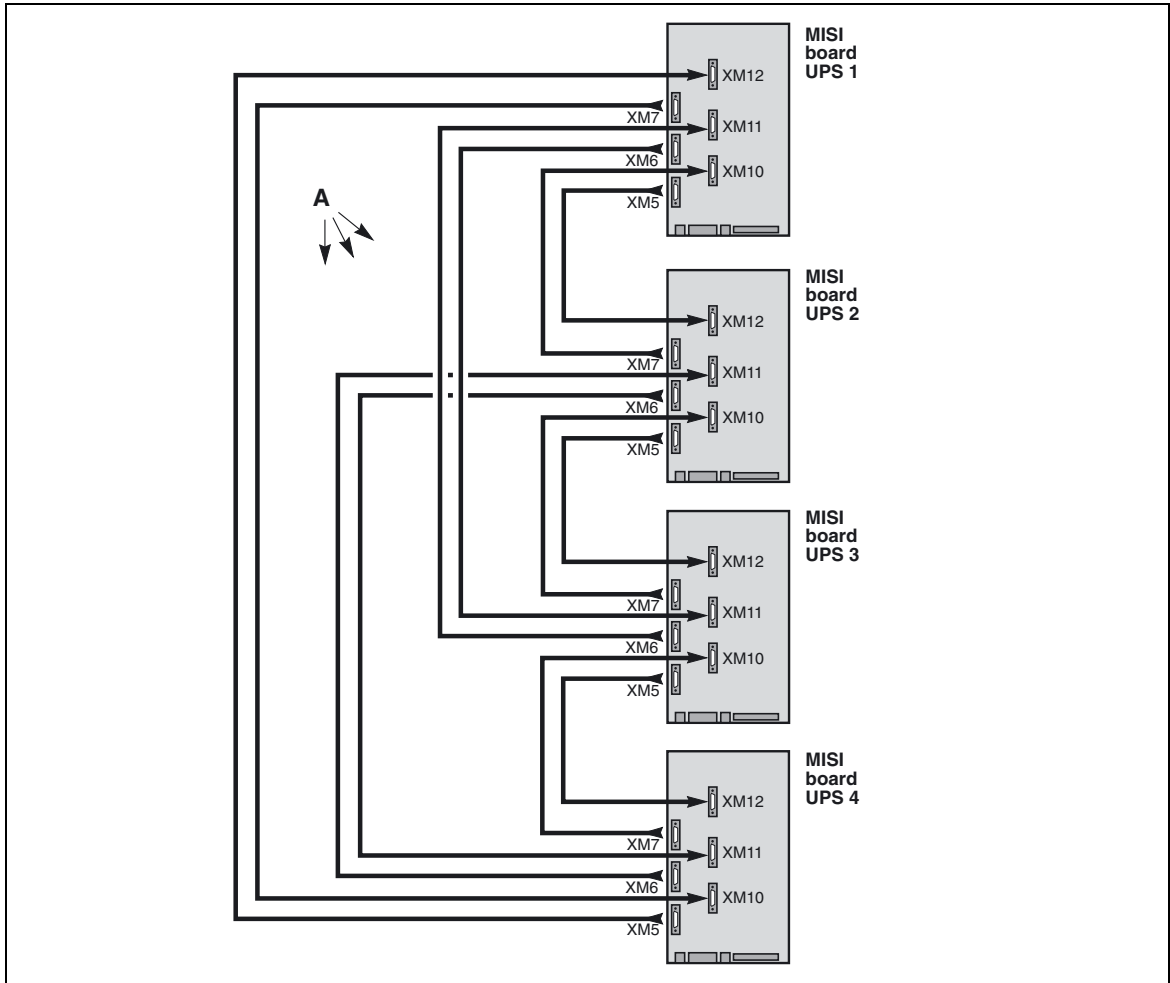
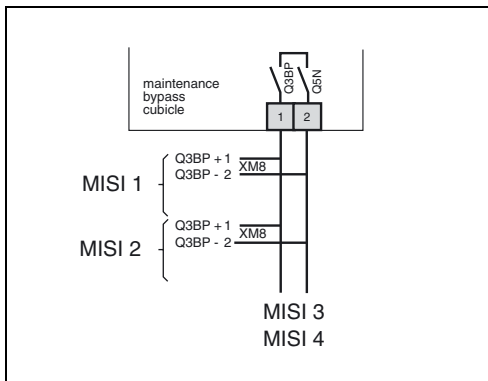

Fig. 21

2.10 Connections between rectifier-inverter cubicles and external maintenance bypass cubicle

- make connections with 1 mm² wires (recommended size, not supplied);
- connect terminals 1 and 2 on connector XM8 on the MISI board in the UPS to terminals 1 and 2 in the external maintenance bypass.



2.11 Connection of "Media Contacts 15" additional auxiliary circuits

(figure 22)

The additional auxiliary circuits of the rectifier-inverter and Static Switch Cubicles are connected to additional remote relay board by means of the 4 connectors (see location of this board in the figures of the "connection of power circuits" section).

- recommended cable cross-section: 1 mm²;
- the male connectors that fit the female connectors on the board (XR5 to XR9) are supplied;
- the contacts are volt-free and are shown in the diagram under the following conditions: UPS on, contact at rest;
- contact breaking capacity: 250 V, 5 A.

Note:

In a parallel-connected UPS installation the "load" and "mains 2" signals are provided by the Static Switch Cubicle.

ACPZ board of the Static Switch Cubicle

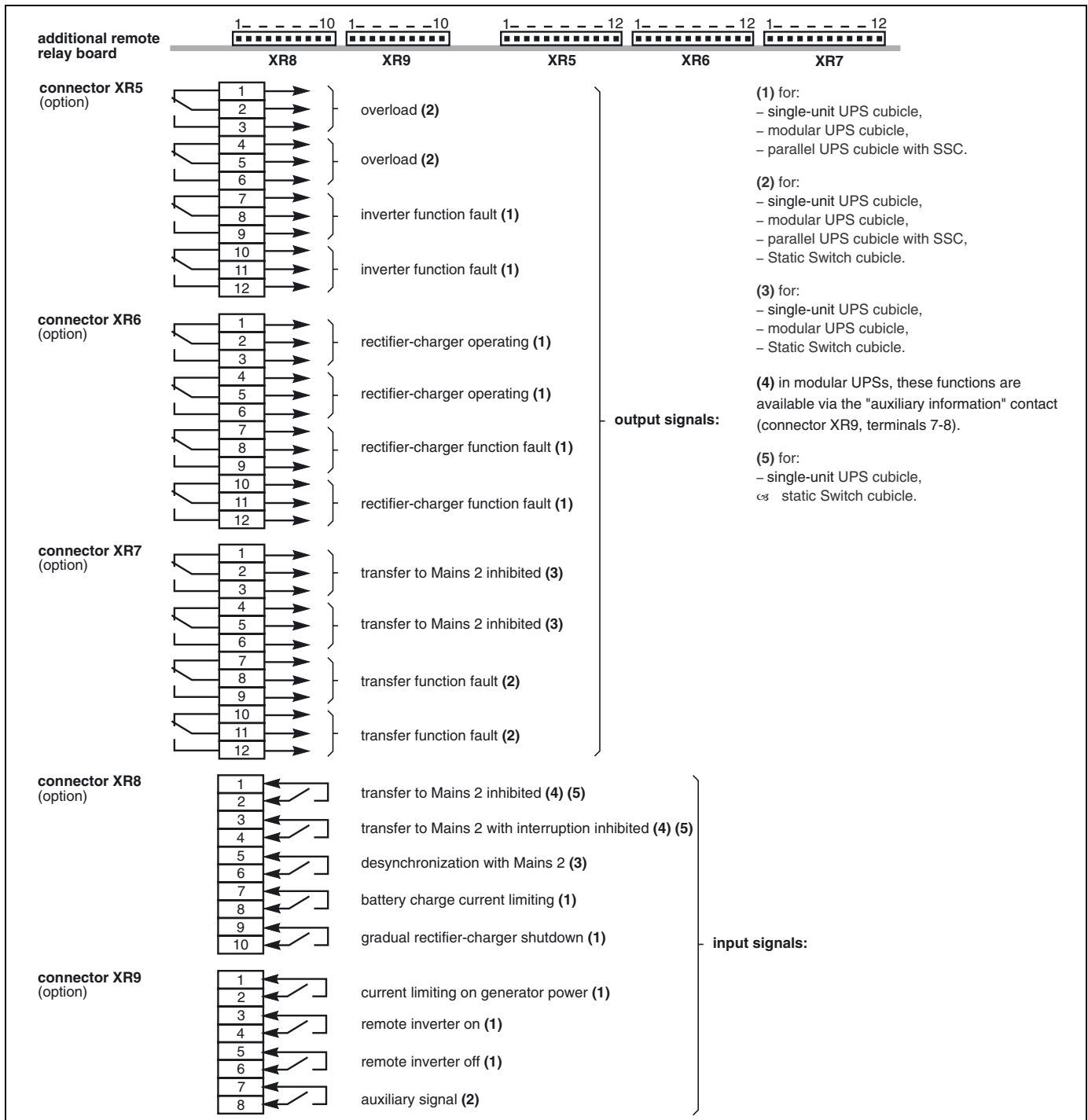

Fig. 22

Installation

2.12 Connection of the battery "Temperature Monitor" (optional)

Connections

This unit must be connected to connector XR4 of the remote relay board of the rectifier-inverter cubicles (see the location of the remote relay board in the figures of the "power circuit connection" section).

- use a shielded cable made up of 2 twisted telephone pairs with a conductor cross-section of at least 0.1 mm² and up to 100 m in length;
- do not forget to connect the cable shield to ground pin 7 of connector XR4;
- in the case of a parallel UPS configuration, the connections between cubicles may be made by means of a shielded cable made up of 1 or 2 twisted telephone pairs. In this case, the total length of all the connecting cables should not exceed 100 m;
- a "Temperature Monitor" can only be connected to several rectifier-inverter cubicles when the batteries of these cubicles are located in the same room at the same ambient temperature.

Connection of the battery "Temperature Monitor" (for a single-unit UPS)

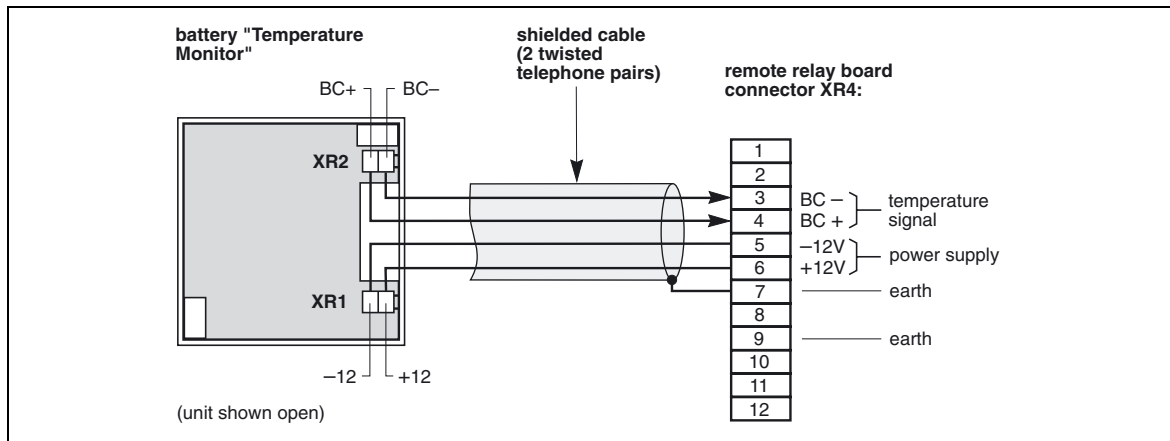

Fig. 23

Connection of the battery "Temperature Monitor" (for a parallel UPS with batteries in the same room)

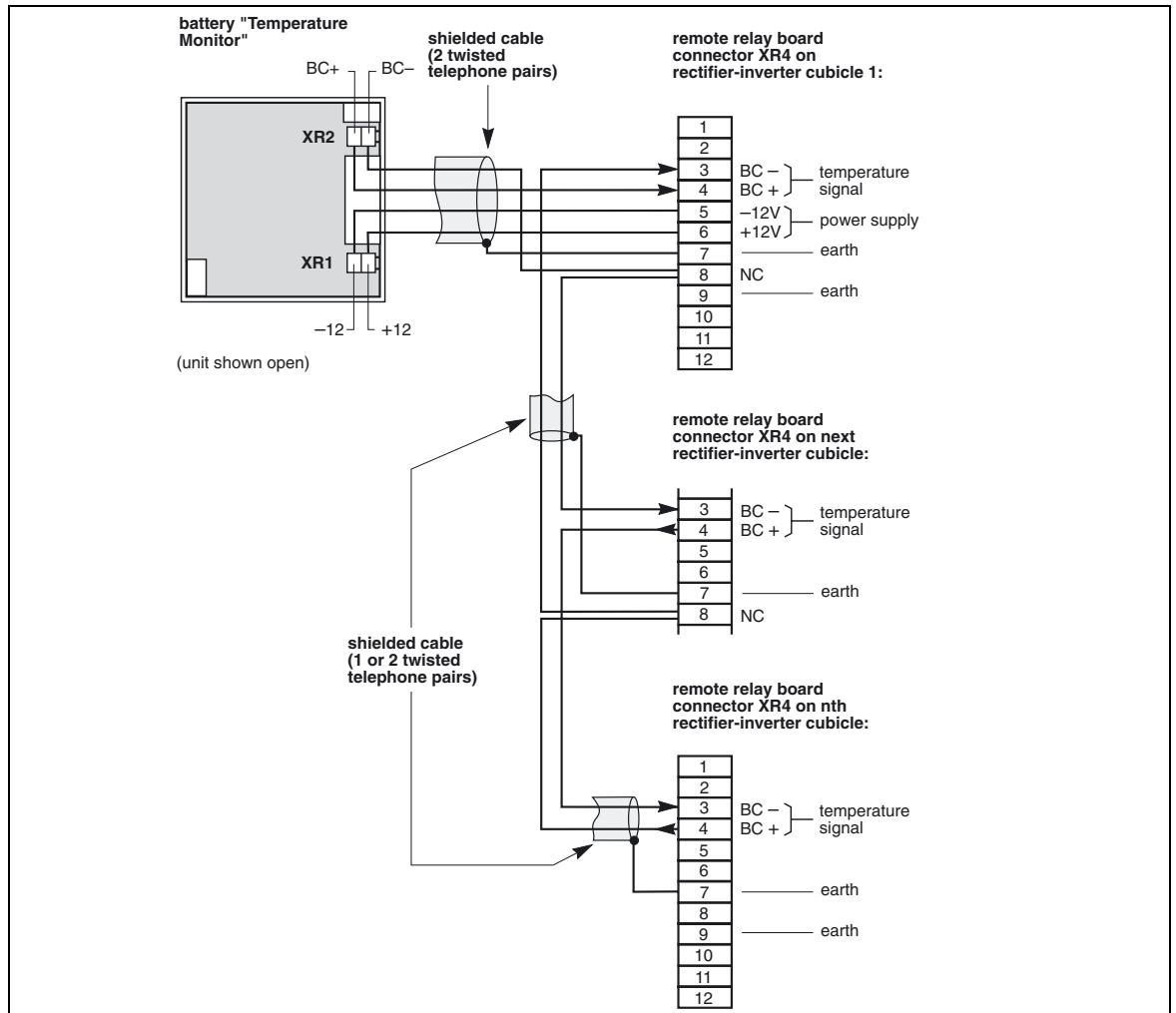

Fig. 24

"Temperature Monitor" installation in a battery room

The "Temperature Monitor" should be secured against a wall or any vertical support:

- choose a location near the batteries and away from draughts which adversely affect the accuracy of temperature measurements;
- position the unit correctly ("on" light in the top left hand corner and cable fed through from the right-hand side);
- use the holes provided in the base plate to screw the unit to the vertical support (see figure 25);
- unless the connecting cable runs on the surface, break the knock-out in the unit base plate provided for cable entry;
- secure the cable by suitable means so that it does not pull on the unit.

"Temperature Monitor" base

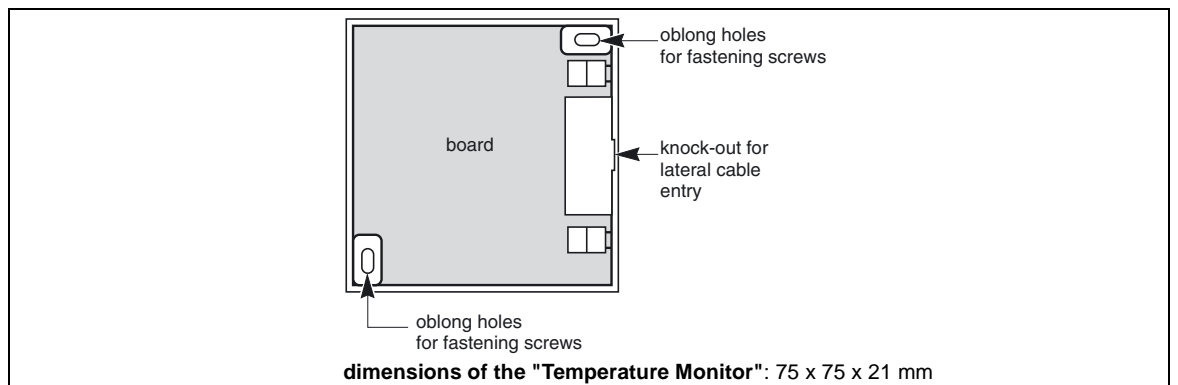

Fig. 25

Installation

2.13 Connection of the "LED" remote indications unit

This unit is connected to connectors XR1 and XR2 of the remote relay boards of the rectifier-inverter and Static Switch Cubicles (see the location of these boards in the figures of the "connection of power circuits" section).

For the installation of the unit and details of connections at the unit end, see the instructions delivered with the unit nr 5102990400.

- recommended cable cross-section: 1 mm².

2.14 Connection of "Tele Monitor" remote control and indication unit (option)

This unit is connected by means of a signal loop connecting the XR10 connectors of the RAUZ 1 boards of the rectifier-inverter and Static Switch Cubicles to the unit connectors. These RAUZ 1 boards are located near the remote relay boards.

- recommended cable cross-section: shielded 0.4 mm² cables;
- consult manual 6739388XU for further information.

Connection of "Tele Monitor" remote control and indication unit

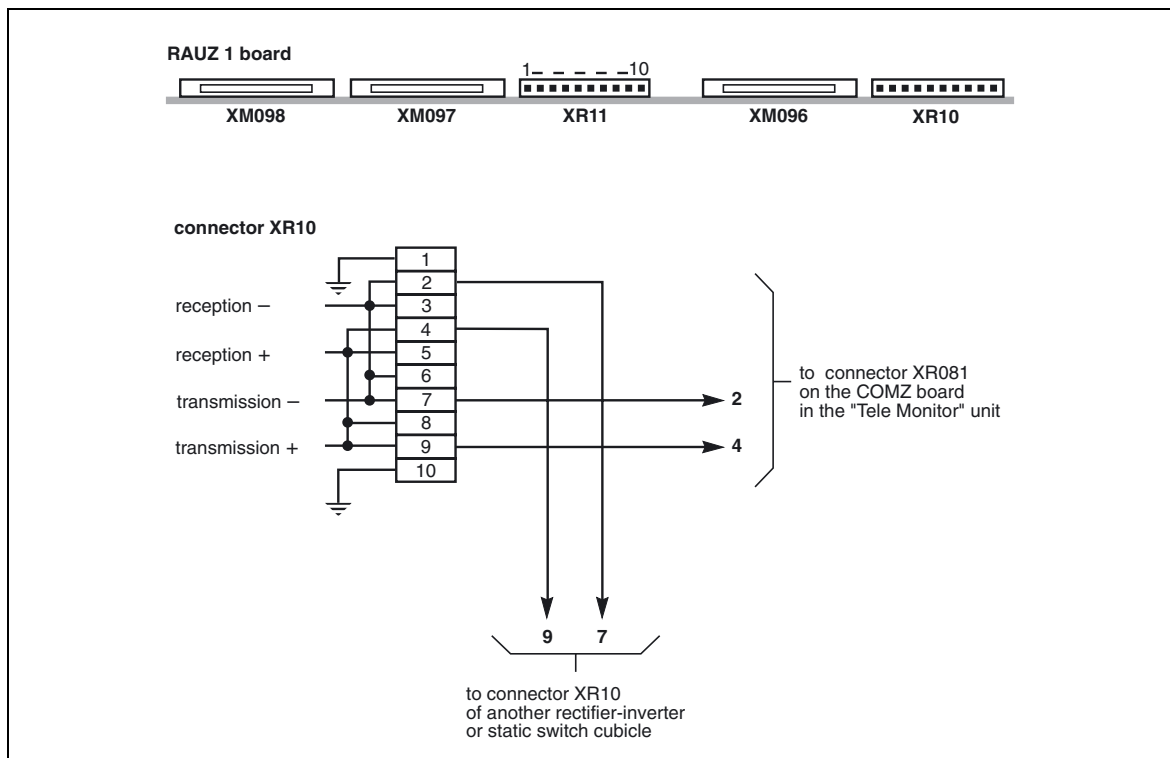

Fig. 26

2.15 Final installation steps

After making the connections:

- install the front and rear base plates of the cubicles, clipping them to the feet of the cubicles (unless the connecting cables are fed through these openings);
- refit the terminal shields of the terminal blocks, switches and circuit breakers.

3. Appendix (to be carried out by qualified personnel only)

3.1 Mains 2 line protection

The rating of the mains 2 line upstream protection circuit-breaker must be chosen:

- to protect the static switch thyristors with respect to maximum permissible currents. Refer to the table opposite for a 400 V mains 2 voltage;
- to ensure discrimination with respect to the UPS output fuses (refer to fuse time-current curves below) and to the downstream protective devices.

rated inverter output (kVA)	maximum permissible current
800	19 In for 20 ms
900	19 In for 20 ms

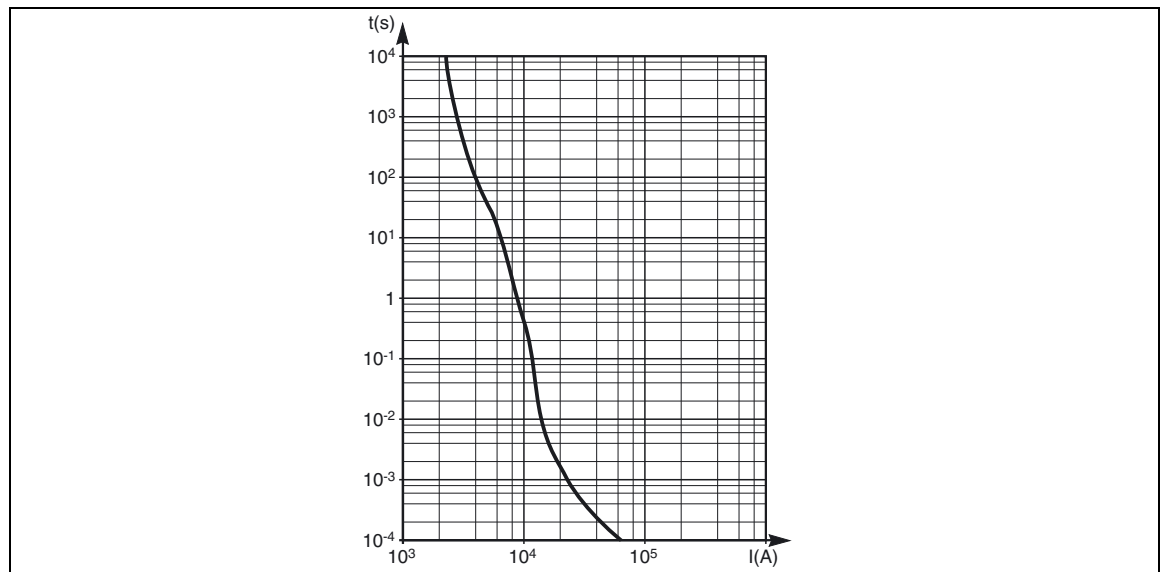

Time-current curve 1600 A fuse

Appendix

3.2 Cubicle mounting and connection for 2000 kVA Static Switch Cubicle

Cubicle mounting

- move the cubicles to their operating location;
- adjust the front foot pads so that the cubicles are vertical and their doors aligned.

Internal connections between cubicles

- install and bolt the supplied fish-plates on the bars for the phases and neutral (L1, L2, L3, N) between the two cubicles (four bars in top and four bars in bottom);
- connect the earth strap to the front uprights of both cubicles;
- connect the connectors marked XM1 and XM2 from the left cubicle to the connectors marked XF1 and XF2 in the right cubicle.

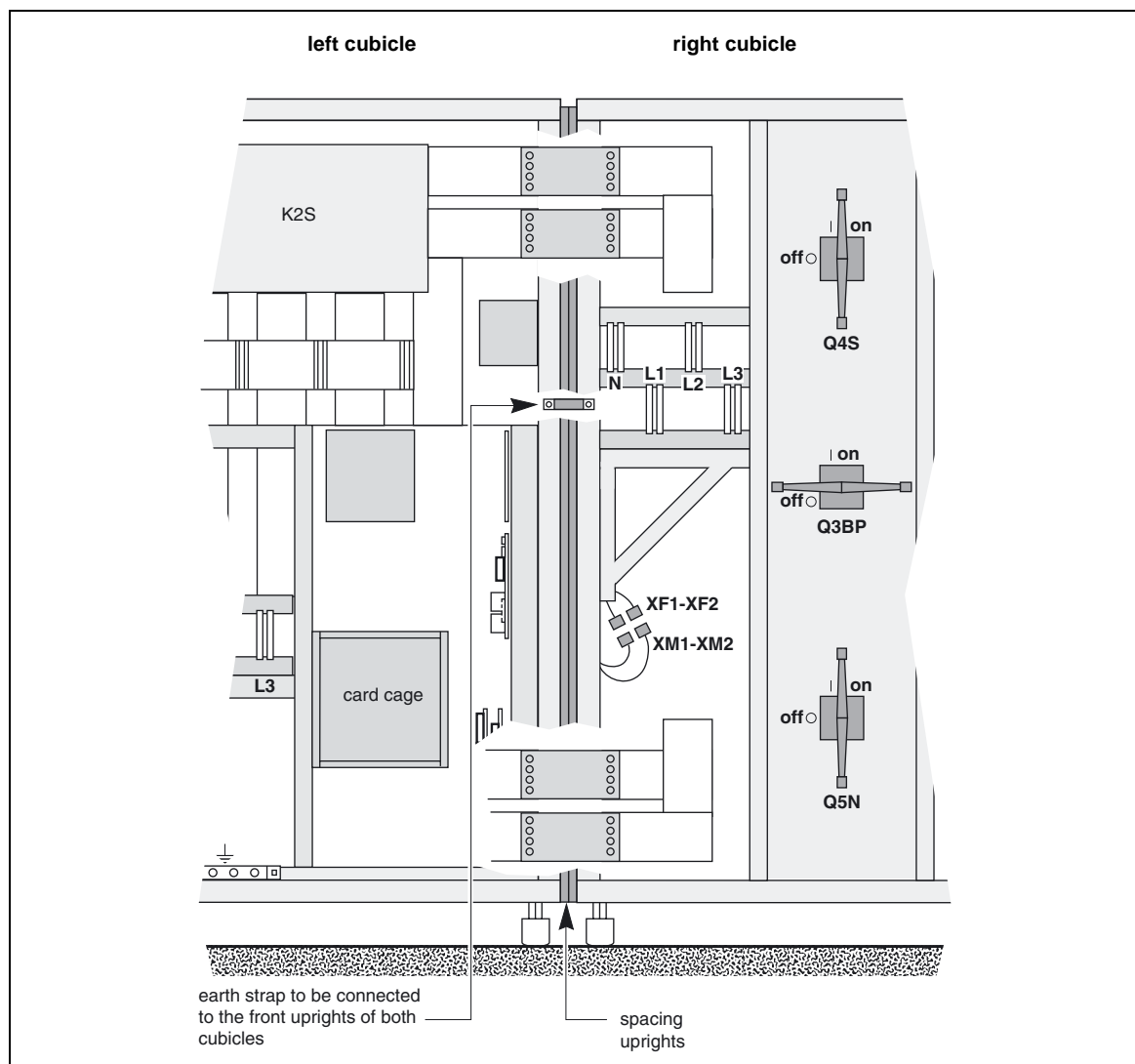

Right cubicle of a 2000 kVA Static Switch

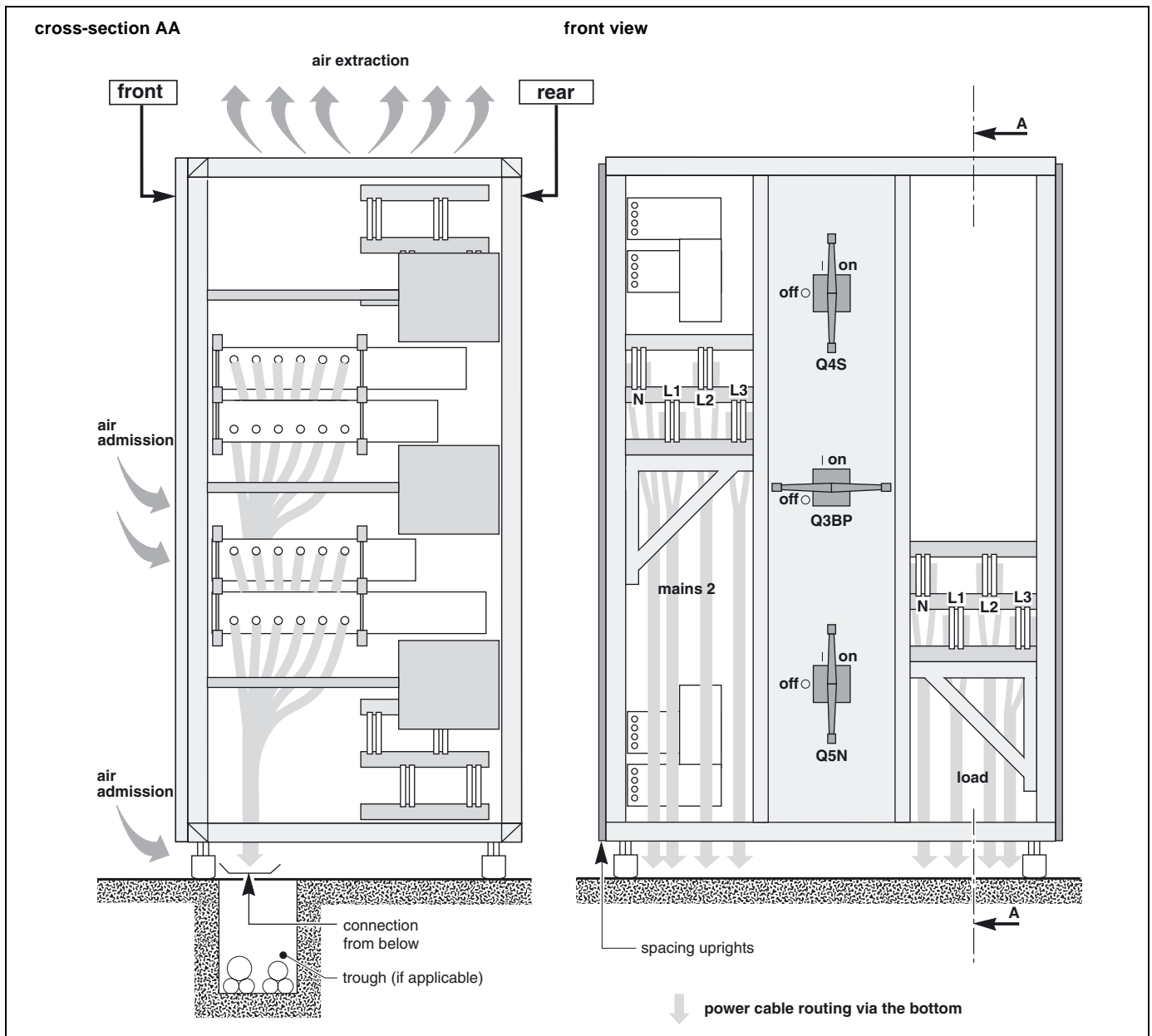

Cables connected by lugs to 5 x (5 x 100) mm copper terminals and 16 mm diameter holes.

Height of connections relative to floor:

- mains 2 : 1400 mm;
- load: 800 mm.

Appendix

Left cubicle of a 2000 kVA Static Switch

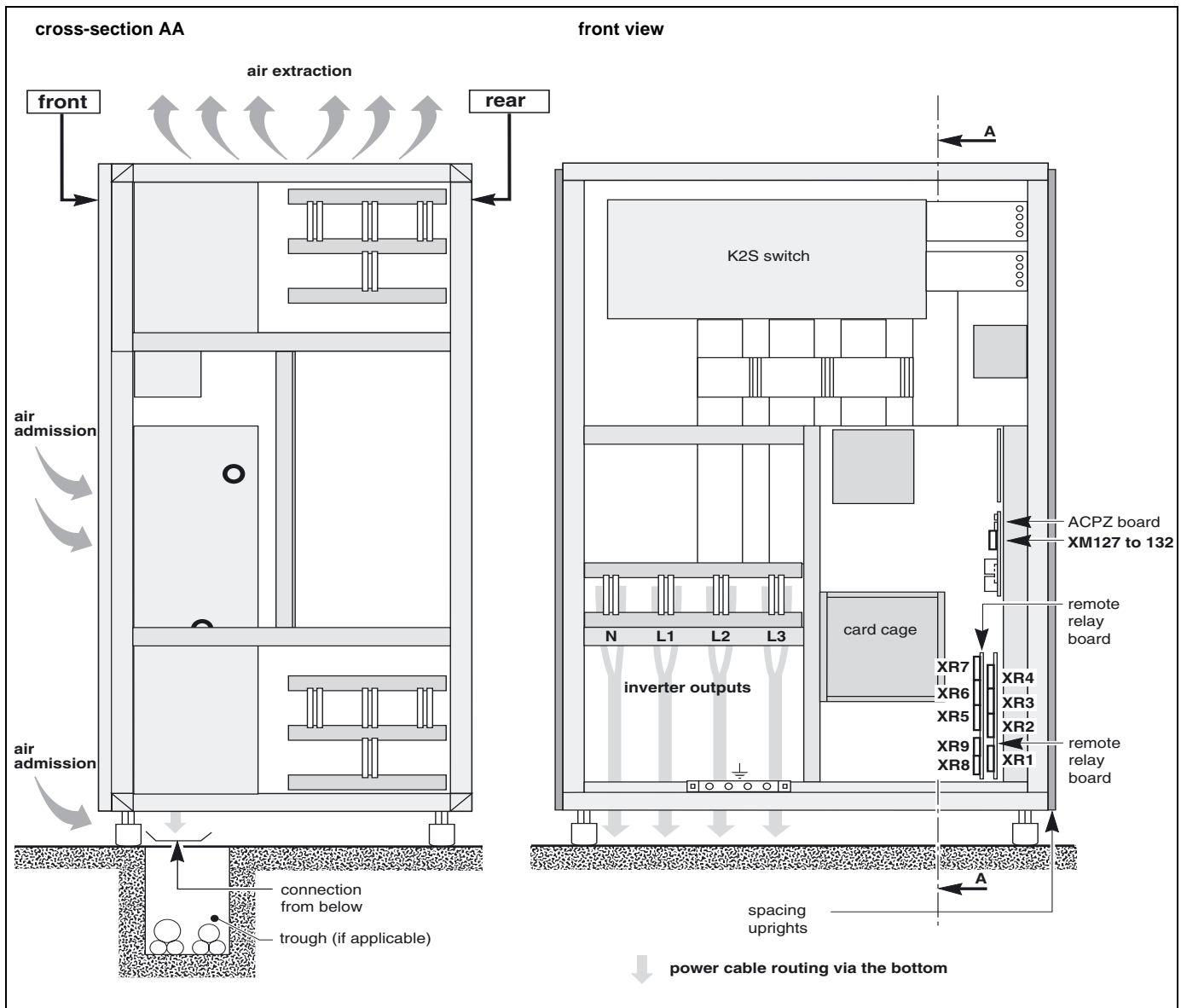

Cables connected by lugs to 5 x (5 x 100) mm copper terminals and 16 mm diameter holes.

Height of connections relative to floor:

- inverter outputs : 700 mm
- remote relay board: 500 mm.

3.3 Details of earthing connections in the various cubicles

Rectifier-inverter cubicle

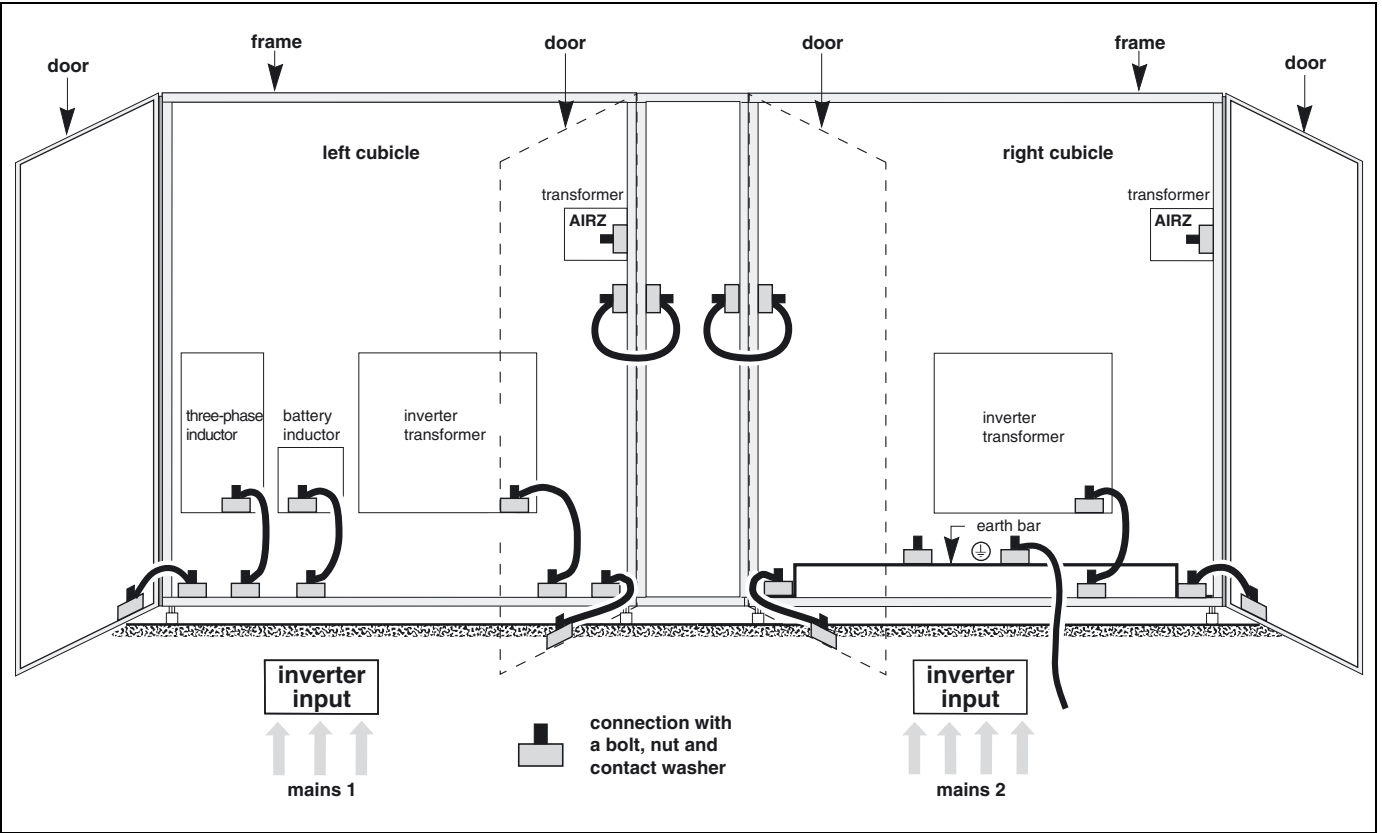

120 to 1200 kVA Static Switch Cubicles

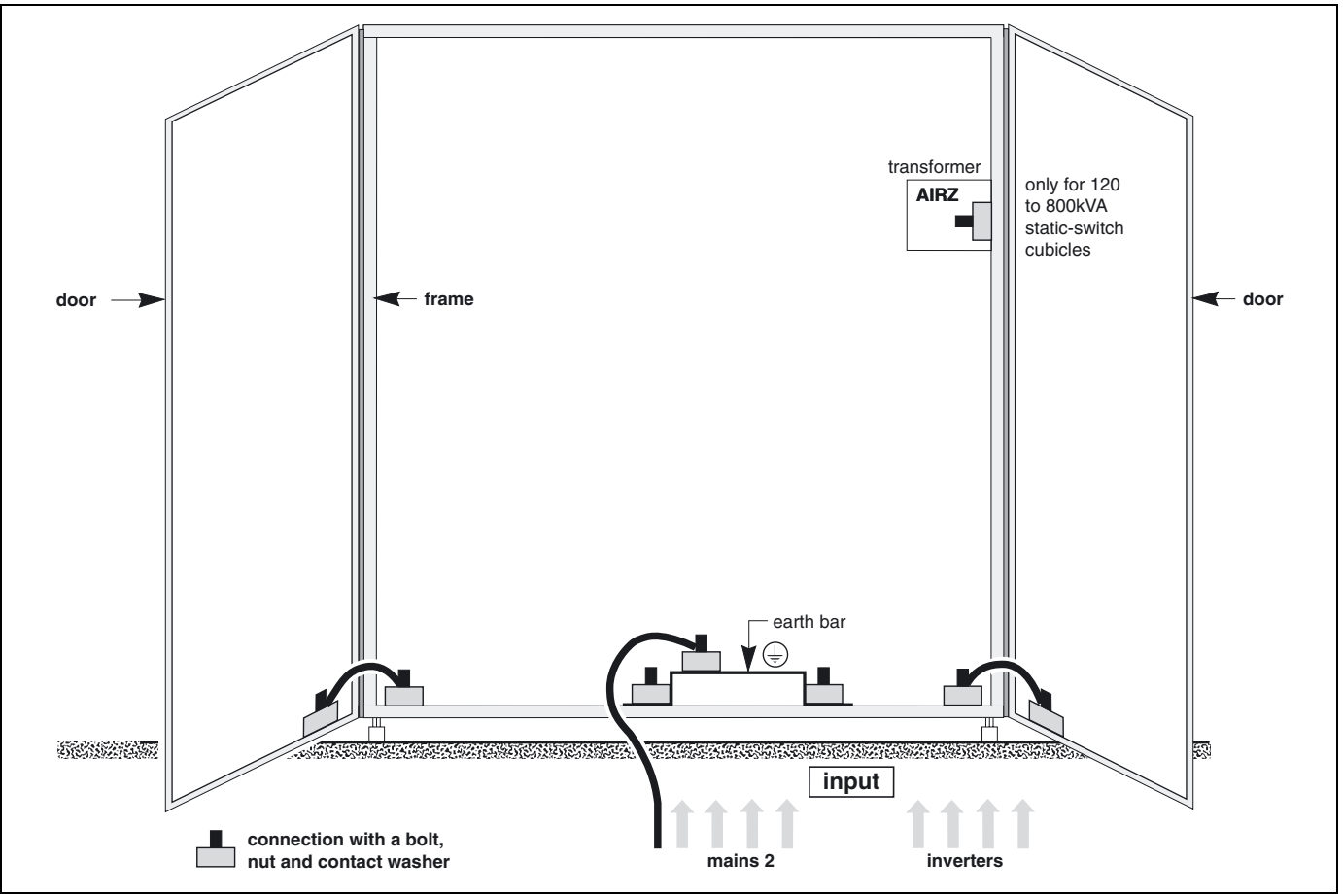

Appendix

2000 kVA Static Switch Cubicles

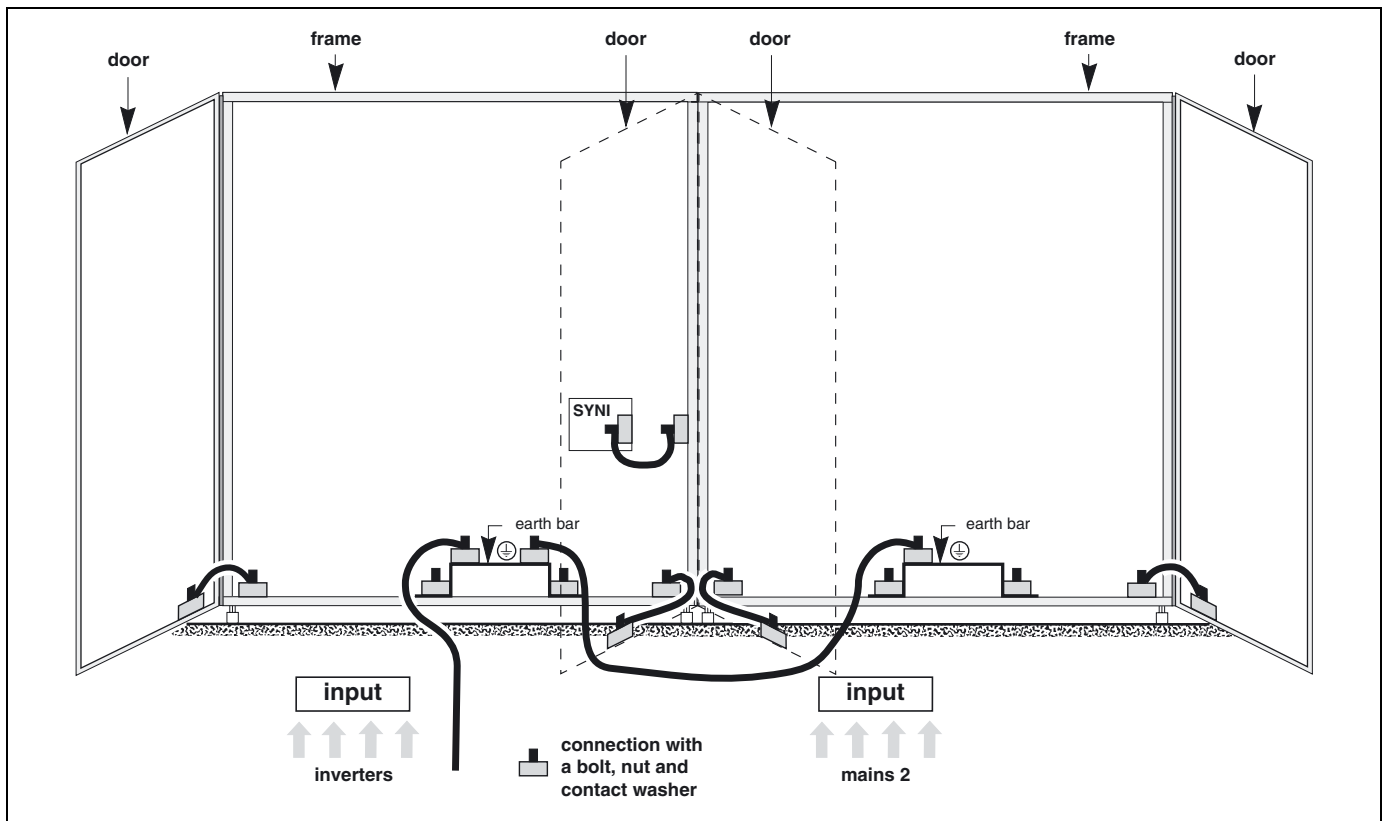

"Tele-Monitor" unit

