



ИБП APC MGE Galaxy 4000 - брошюра на продукцию. Юниджет

Постоянная ссылка на страницу: <https://www.uni-jet.com/catalog/istochniki-besperebojnogo-pitaniya/on-line-ibp-10-100-kva/apc-mge-galaxy-4000.html>



MGE Galaxy 4000

40/50/65/75 kVA

Where reliability meets performance



40 – 75 kVA robust three-phase power protection designed to meet a wide range of requirements from medium data centers to industrial and facilities applications

- Transformerless design
- Ease of installation
- Front access servicing
- Dual input
- Top or bottom entry

Features and benefits

Robust three-phase power protection designed to meet a wide range of requirements from data centers to facilities and transportation applications

The MGE Galaxy™ 4000 delivers centralized three-phase power protection combined with the reliability you expect from the MGE family of products. Ideal for small to medium data centers, facilities, and transportation, the MGE Galaxy 4000 provides high availability, and protection against all power quality disturbances with online double conversion technology that fully isolates between input and output, and zero transfer time for critical loads. Total cost of ownership is reduced by eliminating UPS oversizing for Power Factor Corrected (PFC) loads, and minimizes installation costs with the use of smaller generators and cabling. Front-panel access greatly enhances serviceability.

Galaxy 4000

Features that make the difference

- **Double conversion online topology**
 - True isolation between the input and output
 - Independence of the input and output voltages and frequency
 - No-break transfer to battery or bypass power
 - Does not rely on the batteries for frequency stabilization
- **Input power factor correction (IGBT rectifier)**
 - Eliminates harmful distortion that is reflected back onto the utility
- **Dual input**
 - Provides two available power/avoids problems related to failure of an input circuit breaker
- **Input distortion management**
- **Digital power quality management system**
 - Output created from hundreds of variable width pulses (pulse width modulation)
 - Control loop compares output to a reference sine wave and makes adjustments or correction pulses to maintain a "power quality envelope"
- **Step load voltage stabilization**
- **Four communication card slots are standard.** Included dry contact relay card provides five dry contacts for UPS status.

Battery system configurations

- **Provided in a remote** or adjacent (joined to UPS) matching cabinet(s)
- **Battery type** sealed, valve-regulated, lead acid cells
- **Battery life** estimated at five years plus, depending on number of discharges
- **Compatible** with "flooded or wet cell" batteries

Serviceability

- **Full-front access** facilitates easy service (all electromechanical connections accessible through the front of the UPS)
- **Self-calibrating boards** (no trim pots or thermal drift)
- **Digital diagnostics port** interfaces with PC and accesses all PCBs and system status
- **Backed by over 400** factory-trained field engineers in North America



MGE Galaxy 4000 features

- 1 Double conversion online topology**
 - True isolation between the input and output
 - Independence of the input and output voltages and frequency
 - No-break transfer to battery or bypass power
 - Does not rely on the batteries for frequency stabilization
- 2 Dual mains input/output**

Allows for top or bottom feed connection to two separate power inputs for increased availability
- 3 Input power factor correction**

Eliminates harmful distortion that is reflected back onto the utility from the UPS from disturbing sensitive equipment sharing the utility power
- 4 Digital power quality management**
 - Output created from hundreds of variable width pulses (pulse width modulation)
 - Control Loop compares output to a references sine wave and makes adjustments or correction pulses to maintain a “power quality envelope.”
- 5 Fault tolerant circuitry**

Fast current limiting avoids overloading the inverter – while the robust static bypass switch feeds enough utility power to clear the fault. The result is that the load will stay protected and the UPS will remain intact.



MGE Galaxy 4000 options

Options

- External maintenance bypass cabinets
- Remote alarm status panel (RASP)
- Remote summary alarm panel (RSAP)
- 42-pole distribution cabinet
- Seismic anchors
- Battery monitoring
- Network management card/Web SNMP
- Advanced power management software

Cabinet configurations

- 42-pole panel board distribution
- Optional main input circuit breaker
- Optional branch circuit monitoring (no local meter)
- Optional internal maintenance bypass with keyed interlock
- External maintenance bypass cabinet
- Optional wall mount external maintenance bypass cabinet

Battery system options

- Provided in remote or adjacent (joined to UPS) matching cabinet(s)
- Battery type: sealed, valve-regulated, lead acid cells
- Cabinet width varies depending on battery capacity
- Battery life estimated at five years plus, depending on number of discharges
- Compatible with “flooded” or “wet cell” batteries

Communication card options

- Network Management Card — manage up to 32 servers (SNMP Based)
- RS232/RS485 Serial interface — serial output (ModBus protocol)
- Multislot communications card expander — adds 3 additional communications ports
- IBM AS/400 volt free contact/remote power off card

Distribution

- 42-pole panel board in separate cabinet
- Smaller branch circuits to be fed directly from the UPS
- Available with optional main input CB
- Available with optional “Branch Circuit Monitoring” that monitors individual branch circuit currents

Seismic brackets

- To secure cabinets to the floor, safe for installation in a seismic zone 4 environment as per UBC 97

External maintenance bypass

Every MGE Galaxy 4000 can be equipped with a wall-mounted external maintenance bypass cabinet. The external maintenance bypass routes power around the entire UPS module allowing the UPS to be completely isolated from utility power.

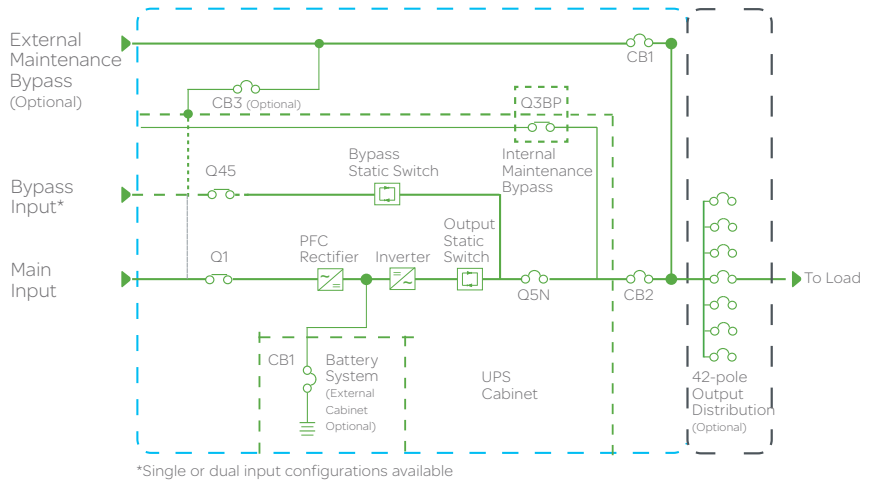

Seismic certification

The MGE Galaxy 4000 has been certified by independent professional engineers to seismic zone 4 specifications. Using the brackets supplied by APC™ by Schneider Electric™ and fastening into the substrate as noted in the installation drawings.



StruxureWare for Data Centers Software Suite

APC by Schneider Electric UPS units and secure power systems are a core component of any architecture designed for highly critical applications, such as data centers, industry environments, infrastructure, and buildings.

Intelligent energy management of these systems is enabled by Schneider Electric EcoStruxure™ integrated hardware and software system architecture. StruxureWare™ software applications and suites are a key element of the EcoStruxure architecture. StruxureWare software helps maximize system reliability and optimize operational efficiency.

StruxureWare for Data Centers software collects and manages real-time information about assets, resource use, and operation status throughout the data center life cycle. This data center infrastructure management (DCIM) software fully integrates the Galaxy PW. With full system visibility, managers can monitor and apply this information in order to optimize data center performance to meet IT, business, and service-oriented goals.



A Comprehensive Portfolio of Services

Schneider Electric Critical Power & Cooling Services (CPCS) provides the highest quality services and solutions by trained and trusted professionals. Our world-class services offer a smart way to build, operate, and maintain your critical applications, ensuring the right people, in the right place, at the right time.

Assembly and Start-Up Service

Assembly and Start-Up Service by a certified Field Service Engineer (FSE) ensures full factory warranty coverage. A Schneider Electric-certified installation ensures your equipment is properly and safely configured for optimal performance. This service features a standard eight-hour, five-day response time, with upgrades available for off-business hours.

Advantage Plans

Flexible service packages offer hassle-free system maintenance to improve uptime at a predictable cost. These packages provide your system with the care it needs to operate most efficiently while minimizing downtime. The Advantage Plus, Prime, Ultra, and Max are full-service packages that include technical support, preventive maintenance, quick on-site response, and remote monitoring. Response time upgrades are available.

Remote Monitoring Service (RMS)

RMS is an economical and easy-to-use Web-based service that lets you quickly respond to environmental or system changes. Trained technicians provide secure 24-hour monitoring of your physical infrastructure to diagnose and resolve problems before they become critical.

Preventive Maintenance

Preventive Maintenance on-site examinations of your critical systems are designed to prevent problems before they occur and keep your system running at maximum efficiency.

On-site Warranty Extension Service

In the event of a system issue, an FSE will arrive on site by the next business day to isolate, diagnose, and correct the problem in as little time as possible, minimizing downtime. Upgrades to even faster response times are available.



Technical specifications

UPS rating (kVA/kW)	40/32	50/40	65/52	75/60
Input				
Voltage (V)	208 V, 3-phase, 4 wire + G			
Frequency (Hz)	60 Hz, + 5%/-5%			
Power factor	>.98			
Current distortion (THDI)	<3% at full load			
Input current (A @ 208 V)	102	127	166	191
Output				
Voltage (V)	208 V, 3-phase, 4 wire + G			
Frequency (Hz)	60 Hz, +-1% (selectable to 4%), +-0.1% free running			
Voltage regulation	+-1% for balanced load +-2.5% for 100% unbalanced load			
Voltage transient response	+-5% for 100% step load +-1% for loss or return of AC input			
Voltage recovery time	Within 1% of nominal within 1 cycle			
Voltage distortion THD	<1% L-L for non-linear loads (<2% max)			
Inverter overload	130% for 1 min, 145% for 30 sec			
Bypass overload	10 X nominal current for 1 cycle			
Output current (A @ 208 V)	111	139	180	208
Environmental				
Max. audible noise	69 dBA @ 3'			
Operating temperature	UPS: 32°F to 104°F Battery: 68 - 77°F			
Storage temperature	-4°F to 113°F			
Relative humidity	0-90% non-condensing			
Operating elevation	0 - 3,333 ft.			
Storage elevation	0 - 30,000 ft.			
Heat rejection BTU/hr	14,900	18,700	24,200	28,000
Dimensions and Weights				
UPS	33.5 X 35.6 X 72.1 in. (1,235 lb. max)			
Battery cabinet 1	26.5 X 33.5 X 72.1 in. (2,045 lb. max)			
Battery cabinet 2	33.5 X 33.5 X 72.1 in. (2,745 lb. max)			
Distribution cabinet	19.5 X 33.5 X 72.1 in.			
Maintenance bypass panel	22.0 X 9.25 X 43 in.			
Regulatory				
Safety	UL 1778, ISO9001			
EMC/EMI/RFI	EN50091-2, IEC 62040-2 FCC15A			
Agency approvals	CE, CSA C22.2 No. 107.3-05			