



uni jet

АЕС IST9 (1 0-20 кВА) - руководство по эксплуатации. Юниджет

Постоянная ссылка на страницу: <https://www.uni-jet.com/catalog/ibp/on-line-ibp/aec-ist9/>



UPS IST9

10 - 20 kVA

User Manual



Foreword

Summaries

Thank you for choosing the Uninterruptible Power System (here in after referred to as the "UPS") product!

This document gives a description of the UPS, including the features, performance, appearance, structure, working principles, installation, operation and maintenance etc.

Please save the manual after reading in order to consult in the future.



NOTE



The figures in this manual are just for reference, for details please see the actual product.





Suitable Model

- 10kVA, 15kVA, 20kVA
- 30kVA, 40kVA

Symbol Conventions

The manual quotes the safety symbols, these symbols used to prompt users to comply with safety matters during installation, operation and maintenance. Safety symbol meaning as follows.

Symbol	Description
 DANGER	Alerts you to a high risk hazard that could, if not avoided, result in serious injury or death.
 WARNING	Alerts you to a medium or low risk hazard that could, if not avoided, result in moderate or minor injury.
 CAUTION	Alerts you to a potentially hazardous situation that could, if not avoided, result in equipment damage, data loss, performance deterioration, or unanticipated results.

Symbol	Description
	Anti-static prompting.
	Be care electric shock prompting.
 TIP	Provides a tip that may help you solve a problem or save time.
 NOTE	Provides additional information to emphasize or supplement important points in the main text.

Contents

1 Safety Description.....	1
1.1 Safety Announcements.....	1
1.1.1 Safety Instructions.....	1
1.1.2 Use Announcements for Battery.....	2
1.1.3 Anti-Static Protection.....	3
1.2 Operation and Maintenance Requirements.....	3
1.3 Environment Requirements.....	3
2 Overview.....	5
2.1 Product Intro.....	5
2.1.1 Features.....	5
2.1.2 Appearance.....	6
2.1.3 Fittings Illustration.....	9
2.2 Work Principle.....	12
2.2.1 Work Principle Diagram.....	12
2.2.2 Work Mode.....	13
2.3 Optionals.....	16
2.3.1 Distribution Module.....	16
2.3.2 Battery Box.....	19
3 Installation.....	20
3.1 Unpacking and Checking.....	20
3.2 Installation Preparation.....	20
3.2.1 Tools.....	20
3.2.2 SelectBreaker&Wires.....	21
3.2.3 Select Input Breaker.....	22

3.2.4 Select Wires	23
3.3 Mechanical Installation	26
3.3.1 Tower-mounting.....	27
3.3.2 Rack-mounting.....	29
3.4 Electrical Connection	31
3.4.1 Wiring Operation of 10kVA-20kVA UPS	31
3.4.2 Wiring Operation of 30kVA-40kVA UPS	32
3.4.3 Wiring Between UPS and Battery Box	34
3.4.4 Wiring Between UPS and Battery Box of 10kVA-20kVA UPS	34
3.4.5 Wiring Between UPS and Battery Box of 30kVA-40kVA UPS	36
3.4.6 Wiring Between UPS and Distribution Module of 10kVA-20kVA UPS	37
3.4.7 Wiring Between UPS and Distribution Module of 30kVA-40kVA UPS	39
3.4.8 Wiring of Parallel System	42
4 Screen Operation.....	48
4.1 Menu Hierarchy	48
4.2 Power On for The First time.....	49
4.3 Main Page	49
4.4 System Working Status Display	50
4.5 Monitoring Page.....	52
4.6 Setting Page.....	52
4.7 Management Setting.....	53
4.7.1 Parameter Setting	54
4.7.2 Function Setting	55
4.7.3 Screen Setting	57
4.7.4 Permission Setting	58
5 Use and Operation	60
5.1 Check Before Startup	60
5.2 Startup Operation	60
5.3 Shutdown Operation.....	61
5.4 Parallel SystemOperation.....	61

5.4.1 Start Parallel System	61
5.4.2 Shut Down Parallel System.....	62
5.4.3 Exit Parallel System Online	62
5.4.4 Add New UPS into Parallel System Online	62
5.4.5 Redundance Function of Parallel System.....	63
5.5 Periodic Preventative Maintenance	63
5.6 Battery Maintenance	63
5.7 Troubleshooting.....	64
5.7.1 Common Fault	64
6 Package, Transportation and Storage.....	69
6.1 Package	69
6.2 Transportation	69
6.3 Storage	69
A Technical Specifications	70

1 Safety Description

This chapter introduces the safety announcements. Prior to performing any work on the UPS, please read the user manual carefully to avoid human injury and device damage by irregular operations.

1.1 Safety Announcements

This section introduces the safety announcements that must be complied with and pay special attention while installing, using, maintenance and other relative operations.



CAUTION

Before operating, please read the announcements and operation instructions in this section carefully to avoid accident.

The DANGER, WARNING, CAUTION, etc. in the manual are not all the safety announcements that you must abide by, they are just the supplements for the safety announcements during operating.



NOTE

Our Company does not undertake the responsibility caused by violating common safety operation requirements or the safety standard of design, manufacture and use.

1.1.1 Safety Instructions



CAUTION

There exists high temperature and high voltage inside the UPS. During using, please strictly comply with all warnings and operation instruments on the UPS and in the user manual.



CAUTION

The UPS is class C3 device. If it is used in residential purpose, it may cause wireless interference. User should take actions to avoid the interference.

- No liquid or other objects are allowed to enter the UPS.
- UPS must be well grounded.
- In case of fire, please use dry power fire extinguisher. If using liquid fire extinguisher, it may cause electric shock.

1.1.2 Use Announcements for Battery



CAUTION

Please use specified battery. Non-specified battery will damage the UPS.

- Only authorized professional can replace battery. Do not wear conductive objects, such as watches, bracelets and rings during operating. Wear rubber shoes and gloves and use tools with insulated handle.
- Don't put tools or other conductive objects on the battery.
- It is prohibited to short the positive pole and negative pole of the battery or connect them reversely, which is to avoid fire or electric shock.
- Before connecting or disconnecting the battery terminals, disconnect charger first.
- The battery must be with the same type, model and manufacturer.
- Battery should be kept away from fire source or other electrical equipments that may easily cause spark to avoid human injury.
- Don't open or destroy the battery. The electrolyte in the battery includes some dangerous objects, such as strong acid, which will be harmful to skin and eyes. If it is careless to touch the electrolyte, clean it by a lot of water immediately and then check it in the hospital.
- The waste battery should be disposed according to the local regulations.

1.1.3 Anti-Static Protection



CAUTION

The static generated by human bodies may damage the electrostatic-sensitive components on PCB. Before touching the sensitive component, please wear anti-static rings and well connect the other end of the anti-static rings to ground.

1.2 Operation and Maintenance Requirements



CAUTION

Only authorized professionals are allowed to open the UPS chassis, or it may cause electric shock and the caused UPS fault is out of the guarantee range.

- If UPS needs to be moved, rewired or maintained, disconnect all electrical connection, such as AC power, battery power, etc. to isolate power input. Do not do any work on the UPS until it is powered off completely (≥ 10 min). Otherwise, the output may exist electricity, which may cause electric shock.
- When dismantling fan, do not put fingers or tools into the rotating fan to avoid device damage or human injury.

1.3 Environment Requirements



DANGER

Do not put the UPS in the environment where has inflammable, explosive gas or smog, do not do any operation in this environment.

- Do not use the UPS in the place where has direct sunshine, rain or wet.
 - The normal work temperature of UPS is $-5^{\circ}\text{C}\sim 40^{\circ}\text{C}$, relative humidity: 0%-95%, with no condensation (recommended work temperature is $20^{\circ}\text{C}\sim 25^{\circ}\text{C}$, humidity is about 50%).
 - Put the UPS in the flat floor without vibration and the vertical gradient is less than 5° . Keep good ventilation around the UPS. The clearance between the rear or the side of UPS and adjacent devices or wall should be at least 300mm \sim 500mm. Poor ventilation
-

will rise temperature inside UPS, which will reduce the service life of inner components and even affect the life span of the UPS.

- The UPS must be used below 2000m. If the altitude exceeds 2000m, it needs to decrease the rated power according to IEC62040-3: 2011 to use.

2 Overview

This chapter mainly introduces the UPS's model meaning, features, structure, work principle, etc.

2.1 Product Intro

UPS is whole high frequency, pure online, double-conversion, smart product. The system is perfect power security for file server, enterprise server, center server, micro-computer, concentrator, telecom system, data center and others that require high quality power protection. They are widely used in many key business areas, such as post, finance, network, stock, railway, etc.

2.1.1 Features

Completely digitalized smart control

10kVA-20kVA UPS support three-in and three-out mode UPS, three-in and one-out mode UPS, one-in and one-out mode UPS.

30kVA-40kVA UPS support three-in and three-out mode UPS, three-in and one-out mode UPS.

The UPS can monitor the grid frequency (50Hz/60Hz) and self-adapt the frequency. The output voltage can be set to 208V/220V/230V/240V, which makes the use more flexible.

Energy conservation and high efficiency

Adopts three-level inverter technology and PFC control technology, the output voltage wave is perfect and the whole efficiency can be 96%, the input power factor is greater than 0.99, which greatly improves the use ratio of electric energy and reduces the load of power grid.

Smart fan speed control

The fan speed is adjusted automatically in accordance with the load status, which prolong fan life and reduce noise.

ECO energy conservation mode design

The UPS is designed with ECO energy conservation mode. When the grid is good, if the UPS operating in this mode, the bypass prior to output, and the efficiency can be 99%.When the bypass voltage or frequency out of normal range and cannot satisfy the user's power supply requirement, it will switch to inverter output, which guarantee the reliability of power supply and also, save energy.

Low mains input voltage

Adopt the independent rapid detection technology. When output load is small, even the battery voltage is 80V, which is the main slow limit, the battery still doesn't discharge. Therefore, in the mains mode, all output power gets from the grid, which is to ensure the battery in 100% energy storage status, and at the same time, reduce the battery discharge times and prolong the service life.

Tower-mounting and rack-mounting

User can select tower-mounting or rack-mounting the UPS according to use space, the LCD also can display corresponding direction on the basis of placement mode.

2.1.2 Appearance

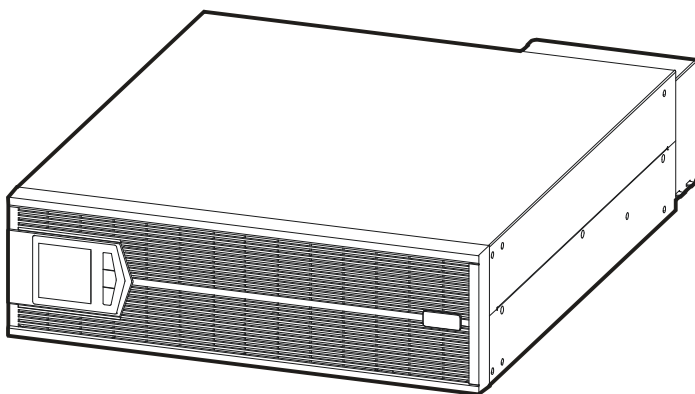

Figure2-1 Appearance

Operation panel

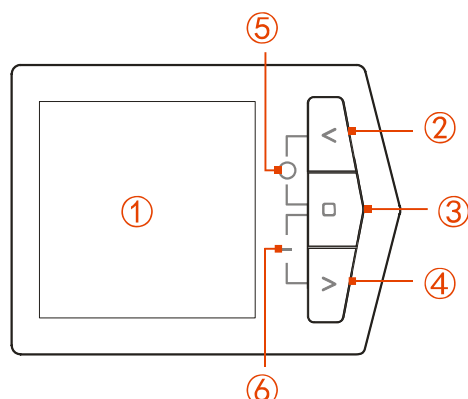

Figure2-2 Operation panel

Table2-1 Illustration for operation panel

No.	Name	Illustration
Illustration for operation panel		
○,1	LCD display	Shows the working status and system setting.
○,2	"<"page up button and power off LED indicator	Short press "<" button, the LCD will enter previous page or previous option.
○,3	"□"function button and breathing light	<ul style="list-style-type: none"> ● Short press "□" button to confirm the command of the current LCD page. ● Long press "□" button for 3s, will enter the parameter and function setting page. ● When UPS is on, "□" button will be in a cycle of light up to fade out.
○,4	">"page up button and power on LED indicator	Short press ">" button, the LCD will enter next setting page.
Combination buttons operation instructions		
○,5	Power off	Press the "<" and "□"button at the same time, the UPS off and the corresponding indicate LED is on.
○,6	Power on	Press the ">" and "□"button at the same time, the UPS on

No.	Name	Illustration
		and the corresponding indicate LED is on.

Rear panel

● 10kVA-20kVA

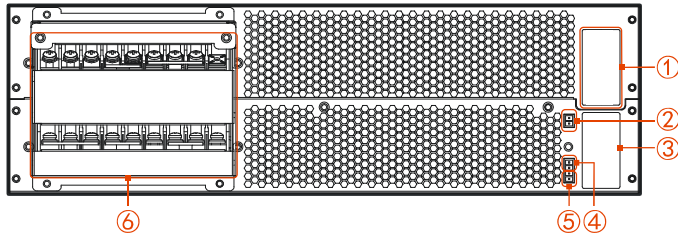

- ① Parallel port (optional)
- ② RS485
- ③ Intelligent slot
- ④ EPO input dry contact
- ⑤ Maintenance bypass switch status detection
- ⑥ Wiring terminal

Figure2-3 Rear panel of 10kVA-20kVA

NOTE

- The wiring terminal of 33 mode and 31 mode have a little different. For the detail of the wiring terminal of each mode please see **3.4.1 Wiring Operation**.
- The intelligent slot is optional: Built-in SNMP card, RS485+dry contact card and communication protocol transfer card.

● 30kVA-40kVA

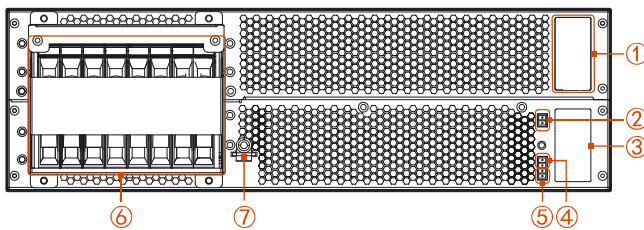

- ① Parallel port (optional)
- ② RS485
- ③ Intelligent slot
- ④ EPO input dry contact
- ⑤ Maintenance bypass switch status detection
- ⑥ Wiring terminal
- ⑦ PE

Figure2-4 Rear panel of 30kVA-40kVA

NOTE

- The wiring terminal of 33 mode and 31 mode have a little different. For the detail of the wiring terminal of each mode please see **3.4.1 Wiring Operation**.

2. The intelligent slot is optional: Built-in SNMP card, RS485+dry contact card and communication protocol transfer card.
3. If the BMD and EPO detection function won't be used, please short the port by equipped 4P terminal. When the function needs to be used, dismantle the short wire of BMD or EPO port and connect it with corresponding status signal input of maintenance bypass breaker or EPO.



CAUTION

Only when the bypass maintain switch state detection (BMD) and EPO port are all shorted respectively, the UPS can work normally.

- If BMD port is disconnected, the UPS will turn to bypass power supply, and at the same time, the LCD shows BMD fault. Once the port recovers short connection, the fault will be removed automatically.
- If the EPO port is disconnected, the UPS will shut down all inverter and bypass output and at the same time, the LCD shows EPO fault. The UPS needs to be power down completely and short connect the EPO port, the fault will be removed automatically.

2.1.3 Fittings Illustration

- 10kVA-20kVA

(10kVA-20kVA) UPS and distribution module has 4 kinds of copper bar, as shown in Table 2-2. Users can connect the copper bar to the corresponding wiring arrangement after UPS or distribution module according to their needs, and set them to 33 mode or 31 mode.

Table 2-2 Copper bar illustration

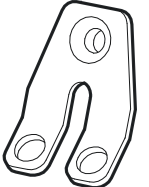
Copper bar No.	Illustration	Sketch map
1#	2PIN copper bar	
2#	2PIN copper bar	

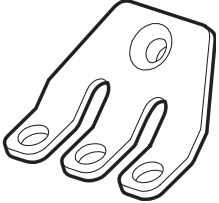
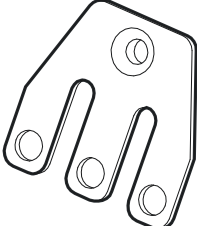
Copper bar No.	Illustration	Sketch map
3#	3PIN copper bar	
4#	3PIN copper bar	

The installation position of the UPS main and power distribution module is as shown in Figure 2-5, Figure 2-6.

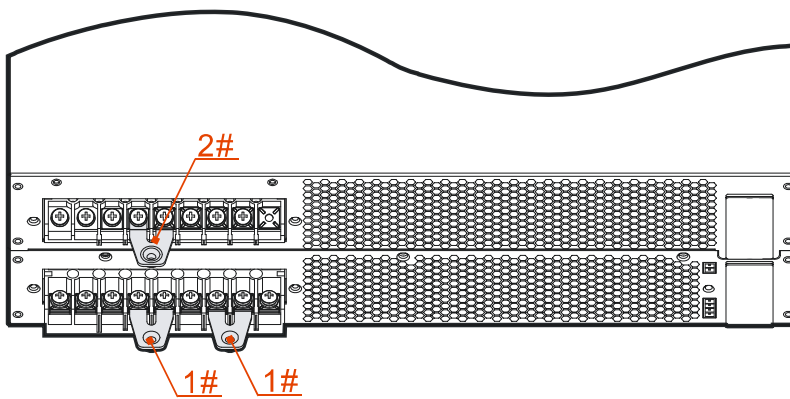

Figure 2-5 Installation 33 mode copper bar position of 10kVA-20kVA UPS

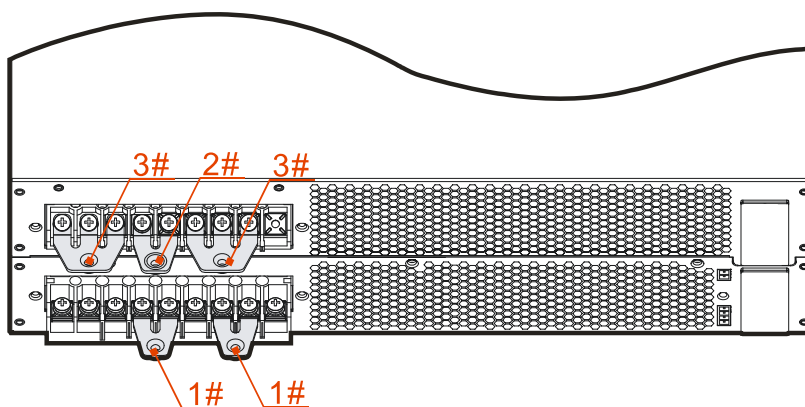
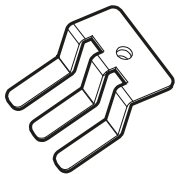
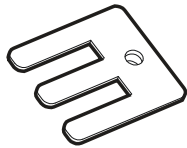

Figure 2-6 Installation 31 mode copper bar position of 10kVA-20kVA UPS

- 30kVA-40kVA

(30kVA-40kVA) UPS and distribution module has 2 kinds of copper bar, as shown in Table 2-3. Connect the wiring terminal of the UPS or distribution module with the copper bar according to needs. The copper bar for short connect with the three phase bypass input terminal and three phase output terminal only for 31 mode UPS.

Table 2-3 Copper bar illustration

Copper bar No.	Illustration	Sketch map
1#	3PIN copper bar	
2#	3PIN copper bar	

The installation position of the UPS main and power distribution module is as shown in Figure 2-7, Figure 2-8.

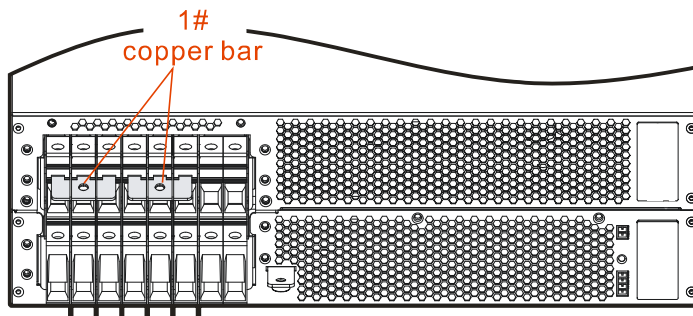

Figure 2-7 Installation 31 mode copper bar position of 30kVA-40kVA UPS

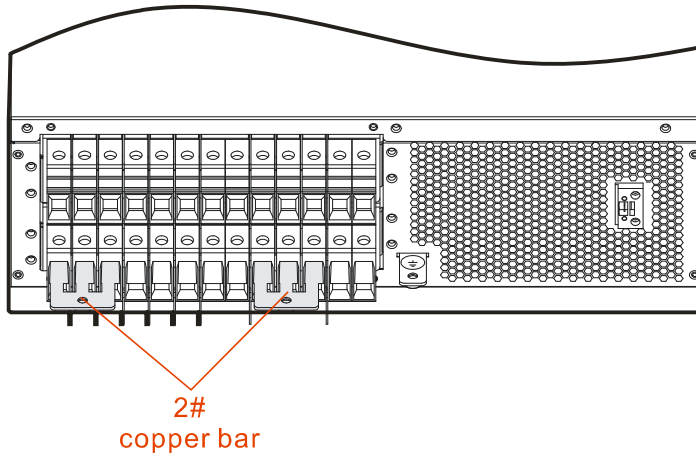

Figure2-8 Copper bar 2# installation position of 31 mode power distribution module

2.2 Work Principle

2.2.1 Work Principle Diagram

Work principle diagram of the UPS is as shown in Figure2-9.

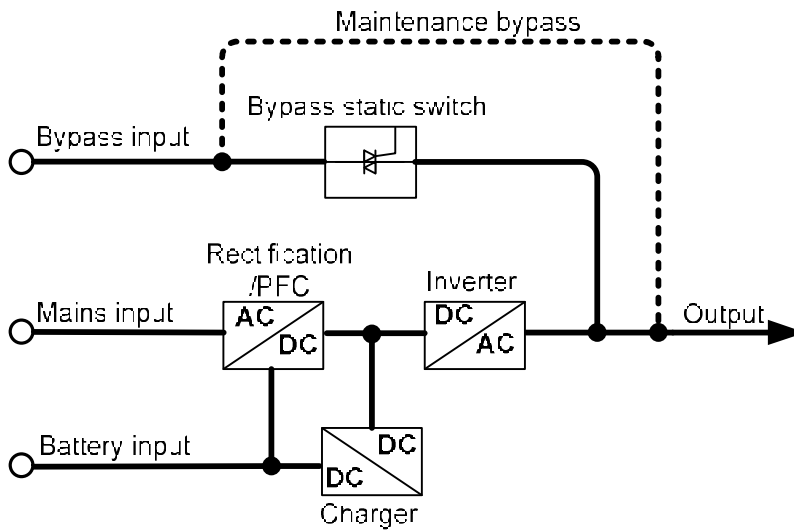

Figure2-9 Work principle diagram

The UPS includes rectification/PFC, inverter, charger, bypass static switch etc function module, the input power includes mains input, bypass input, battery input, the output mode includes inverter output, bypass output and maintenance bypass output (if equipped).

When mains normal, the rectifier starts and the charger charges the battery at the same time. When UPS off, if bypass normal, the system turns to bypass output; when UPS on, the mains boosts by rectification/PFC and output DC bus voltage, and then go through inverter

and output pure sine-wave AC power, the output turns to inverter output to load from bypass output (if equipped).

When mains abnormal, the battery voltage boosts by rectification/PFC and output DC bus voltage, and then go through inverter and output pure sine-wave AC power to load. When mains recover normal, the UPS turns to mains mode from battery mode automatically.

2.2.2 Work Mode

There are 5 work modes of the UPS: normal mains power supply mode, battery inverter mode, bypass power supply mode, ECO power supply mode and maintenance bypass power supply mode. The maintenance bypass power supply mode can only suitable for install the UPS series fitting with distribution module.

Normal mains power supply mode

When mains power normal, the UPS works in mains inverter status and charge the battery at the same time. The work mode is as shown in Figure2-10.

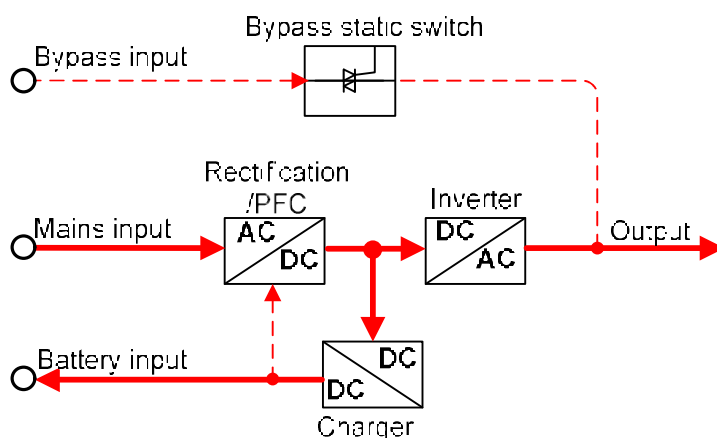

Figure2-10 Normal mains power supply mode (the thick solid line stands for the energy flow direction)

Battery inverter mode

When mains abnormal, the rectifier will transfer to battery input immediately, boost the battery voltage and then maintain the voltage of DC bus voltage to guarantee the inverter output continuous. As shown in Figure2-11.

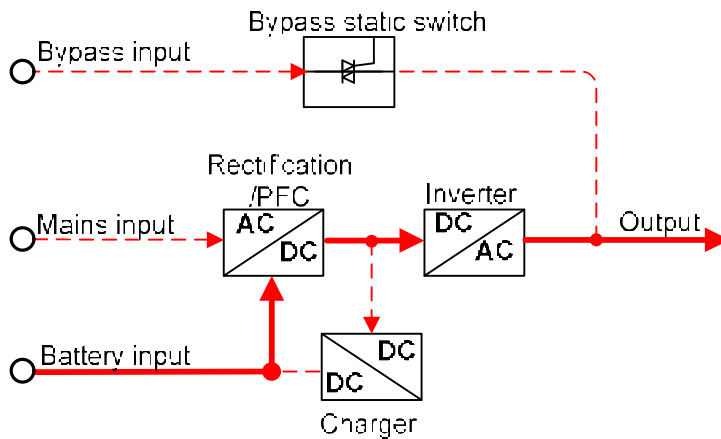

Figure2-11 Battery inverter mode (the thick solid line stands for the energy flow direction)

Before the battery stop discharging, if the mains recover normal, the rectifier will transfer to mains input automatically and charge the battery at the same time. That is to say, the UPS recover normal mains power supply mode. If the mains always abnormal and the battery is running up, the UPS will send sound and light alarm and stop working till battery low-voltage point. At that time, the buzzer long beeps to alarm, the power for load powers down. Under the circumstance of mains power outage completely, the UPS will shut down about 1min later automatically and close the power of the UPS to avoid the battery discharge slimly, thus to protect the service life of battery. Once the mains recovers, the UPS will start automatically and turn to normal mains power supply mode.

Bypass power supply mode

Under the circumstance of bypass voltage normal, when UPS off or fault (such as inverter output overload, over-current surge or IGBT over-temperature etc) while UPS on, the UPS will output by bypass. When UPS on and the fault removed, it will turn to inverter output again. If the same fault occurs more than 5 times in a short time, the UPS protects and output by bypass until power off manually or power down and remove the fault, restart the UPS and then it will recover normal work.

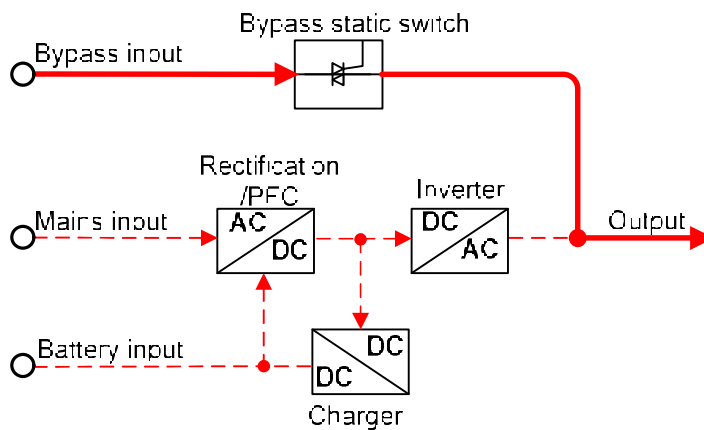

Figure2-12 Bypass power supply mode (the thick solid line stands for the energy flow direction)

ECO power supply mode (just suitable for single UPS)

At the ECO mode, when bypass voltage normal, the power for load is prior supplied by bypass, when bypass voltage abnormal, the power for load turns to inverter. ECO mode is an economic operation mode. For the load which does not require high quality, user can select ECO mode to reduce the energy consumption. At the ECO mode, the UPS efficiency can be 99%.

Maintenance bypass power supply mode (suitable for the system with distribution module)

When the UPS needs to be maintained and the power supply for load cannot be interrupted, user can shut down the inverter and make the UPS works in bypass status, then switch on the maintenance bypass breaker and switch off the mains input breaker and bypass input breaker, output breaker. During the transforming of manual maintenance bypass, AC power is supplied for load by maintenance bypass breaker. At this time, the inner UPS has no electricity, maintainer can perform the maintenance safely.

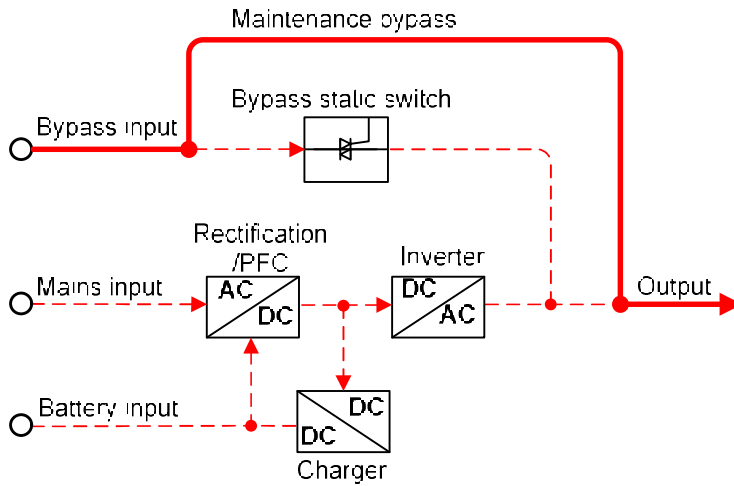

Figure2-13 Maintenance bypass power supply mode (the thick solid line stands for the energy flow direction)

2.3 Optionals

UPS can equip distribution module or battery box according to needs.

2.3.1 Distribution Module

Appearance

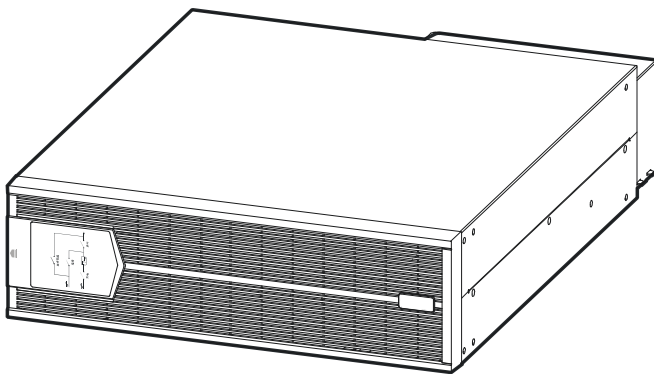

Figure2-14 Appearance of distribution module

Front panel of 10kVA-20kVA

The operation breakers of distribution module locate inside the front panel, when operating, it needs to open the front panel fist. Open the front panel way as shown in Figure2-15.

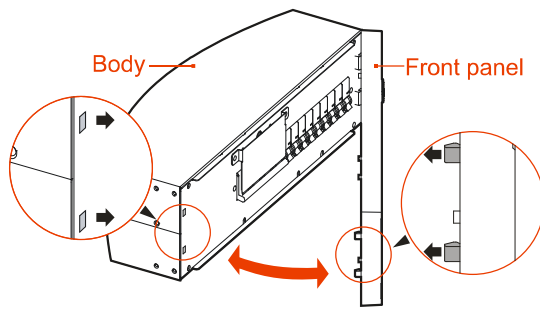
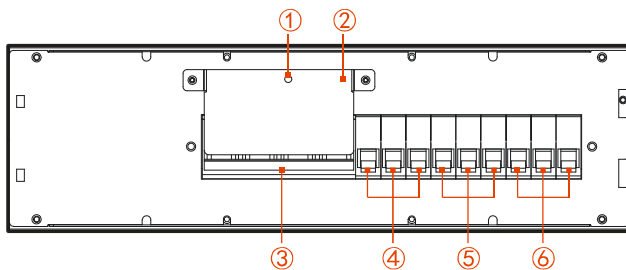

Figure2-15 Open the front panel of 10kVA -20kVA UPS

NOTE

When install the front panel, insert the buttons at right side into the body, and then insert the buttons at left side into the body.



- ① Maintenance bypass status detection switch
- ② Protection plate of maintenance bypass breaker
- ③ Maintenance bypass breaker
- ④ AC output breaker ⑤ AC input breaker
- ⑥ Bypass breaker

Figure2-16 Distribution module illustration (dismantle front panel) of 10kVA -20kVA UPS

Rear panel of 10kVA-20kVA

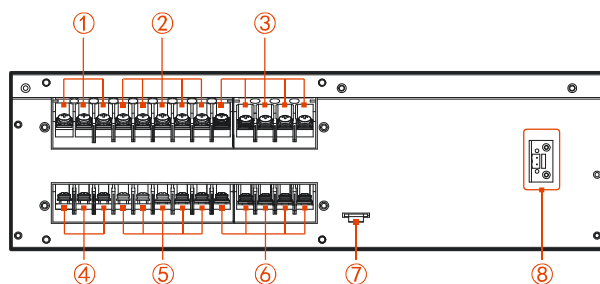

- ① UPS bypass terminals ② UPS input terminals
- ③ UPS output terminals ④ User bypass terminals
- ⑤ User input terminals ⑥ User output terminals
- ⑦ PE ⑧ Bypass maintain detection

Figure2-17 Distribution module illustration (dismantle front panel) of 10kVA -20kVA UPS

Front panel of 30kVA-40kVA

The operation breakers of distribution module locate inside the front panel, when operating, it needs to dismantle the front panel fist. Open the front panel way as shown in Figure2-18.

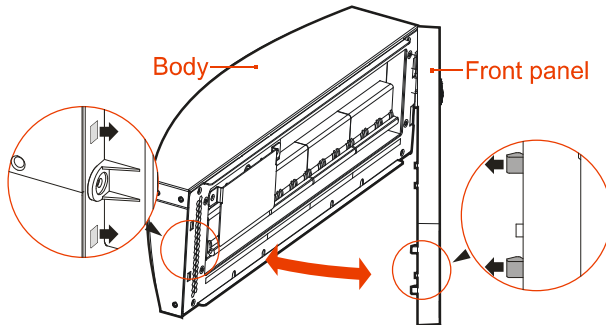
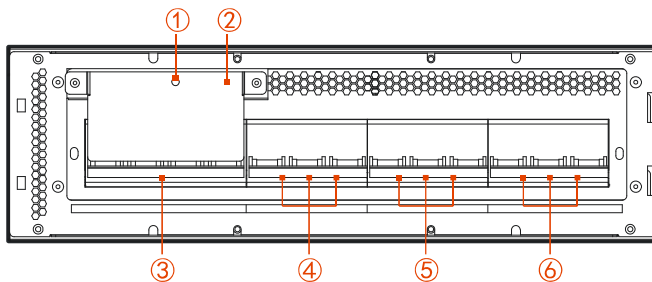

Figure2-18 Open the front panel of 30kVA -40kVA UPS

NOTE

When install the front panel, insert the buttons at right side into the body, and then insert the buttons at left side into the body.



- ① Maintenance bypass status detection switch
- ② Protection plate of maintenance bypass breaker
- ③ Maintenance bypass breaker
- ④ AC output breaker ⑤ AC input breaker
- ⑥ Bypass breaker

Figure2-19 Distribution module rear panel of 30kVA -40kVA UPS

NOTE

Operation method of maintenance bypass mode: dismantle the protection plate of maintenance bypass breaker, the detection switch of maintenance bypass status pop up automatically, the UPS close the inverter and turn to bypass to supply power, then close the maintenance bypass breaker, turn off the AC input breaker, bypass breaker and AC output breaker, at this time, the power for load turns to maintenance bypass, the input and output of the UPS is disconnected, the maintenance can be done.

Recover inverter power supply from maintenance bypass power supply: connect the wires of UPS and distribution module (including bypass maintain detection signal wire), and then close the AC input breaker, bypass breaker and AC output breaker, after the work power of UPS normal and the LCD show bypass output voltage, turn off the maintenance bypass breaker and lock the protection plate of maintenance bypass breaker, finally, press the power on button to start the inverter to supply power.

Rear panel of 30kVA-40kVA

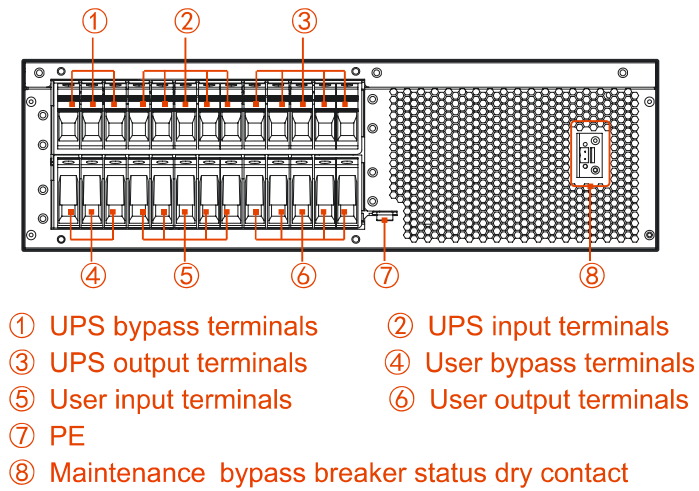

Figure2-20 Distribution module rear panel of 30kVA -40kVA UPS

2.3.2 Battery Box

Appearance

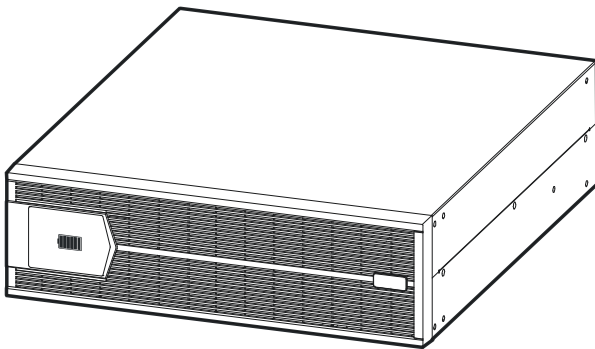

Figure2-21 Appearance of battery box

Rear panel

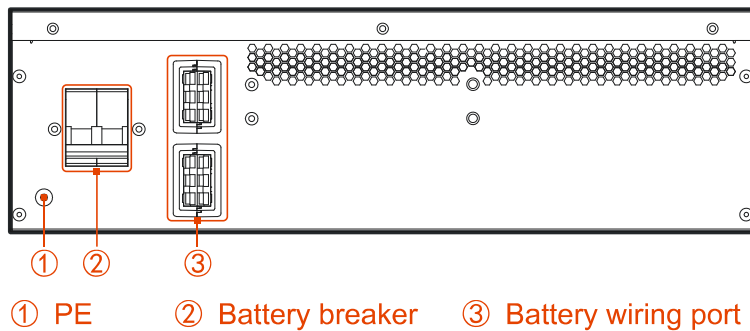

Figure2-22 Rear panel of battery box

3 Installation

This chapter mainly introduces the installation of the UPS, including unpacking and checking, cable selection, installation, electrical connection, etc.





3.1 Unpacking and Checking



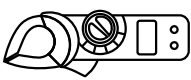
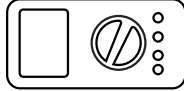

Unpack and check the UPS according to follows.

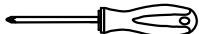
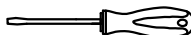
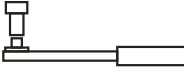
- Inspect the appearance for shipping damage. If any shipping damage is found, report it to the carrier immediately.
- Check the delivery list to see if the types of accessories are complete and correct. If there is any discrepancy, contact the distributor immediately.

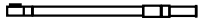
3.2 Installation Preparation

3.2.1 Tools

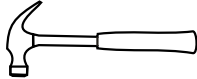
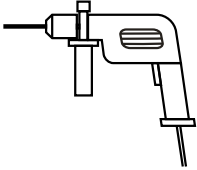
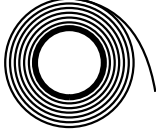
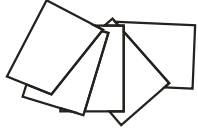
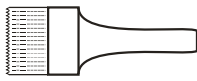
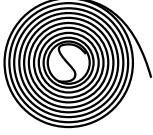
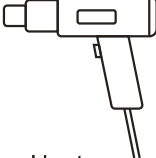
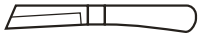
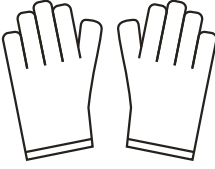
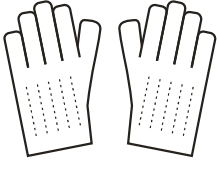
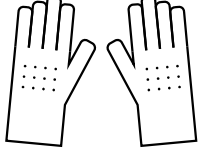
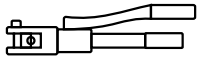
Tools			
 Clamp meter	 Multi-meter	 Label paper	 Phillips screwdriver
 Flat-headscrewdriver	 Socket wrench	 Adjustable wrench	 Torque wrench

Tools			
 COAX crimping tool	 Diagonal pliers	 Wire stripper	 Claw hammer
 Hammer drill	 Insulation tape	 Cotton cloth	 Brush
 Heat shrink tubing	 Heat gun	 Electrician's knife	 Protective gloves
 ESD gloves	 Insulated gloves	 Hydraulic pliers	 Cable tie

3.2.2 Select Breaker&Wires

The selecting for AC input and output wire, DC input wire and corresponding breakers needs to be judged by the UPS' max. steady state phase current. Table3-1 shows the max. steady state phase current of each work mode, Table3-2 shows the rated current of recommended breakers, Table3-3 shows the min. recommended wire cross-sectional area. Select the wires and breakers according to Table3-1, Table3-2, Table3-3.

Table3-1 UPS max. steady state phase current

type	10kVA			15kVA			20kVA			30kVA		40kVA	
	33	31	11	33	31	11	33	31	11	33	31	33	31
Mode type	33	31	11	33	31	11	33	31	11	33	31	33	31
AC input(A)	18	18	54	26	26	78	35	35	10	59	59	75	75

type	10kVA			15kVA			20kVA			30kVA		40kVA	
Mode type	33	31	11	33	31	11	33	31	11	33	31	33	31
									5				
Bypass input (A)	15	46	46	23	68	68	31	91	91	45	136	61	182
DC input(A)	29	29	29	44	44	44	58	58	58	83	83	111	111
AC output (A)	15	46	46	23	68	68	30	91	91	45	136	61	182

3.2.3 Select Input Breaker

We suggest to add a breaker (we suggest to select the breaker with feedback double pole disconnection equipment) or distribution cabinet that matches the UPS power at the front of the UPS input to insulate the mains. Considering the UPS charge power and the impact current while power on, the selected breaker must be 1.5 to 2 times of UPS input max. current and cannot with leakage protection, which is to avoid wrong action of breaker. The distribution box should be manufactured by professional company. The breaker of DC input should be select more than the 250VDC. The selection of breaker, please reference Table3-2.

Table3-2 Recommended input breaker list

type	10kVA			15kVA			20kVA			30kVA		40kVA	
Mode type	33	31	11	33	31	11	33	31	11	33	31	33	31
AC input (A)	32*	32*	63*	50*	50*	100	63*	63*	125	100	100	100	100
	3P	3P	1P	3P	3P	*1P	3P	3P	*1P	*3P	*3P	*3P	*3P
Bypass input (A)	32*	63*	63*	50*	100	100	63*	125	125	100	200	100	250
	3P	1P	1P	3P	*1P	*1P	3P	*1P	*1P	*3P	*1P	*3P	*1P
DC input (A)	50*	50*	50*	63*	63*	63*	80*	80*	80*	125	125	175	175
	3P	3P	3P	3P	3P	3P	3P	3P	3P	*3P	*3P	*3P	*3P
AC output (A)	32*	63*	63*	50*	100	100	63*	125	125	100	200	100	250
	3P	1P	1P	3P	*1P	*1P	3P	*1P	*1P	*3P	*1P	*3P	*1P

3.2.4 Select Wires

For the wire cross-sectional area of AC input, output and battery please see the recommended value in Table3-3 Table3-4 and Table3-5. The cross-sectional area of the following cable is only for reference when the user is connected wire for a length of about 5 meters. If the length of the lead wire exceeds 20 meters, the cross-sectional area of the conductor wire shall be increased.

NOTE

For 10kVA-20kVA UPS is set to 31 mode or 11mode, since the UPS is equipped with input and output three-phase connector, the bypass input and out wires are recommended according to the single wire. When the UPS is set to 11mode, the UPS is not equipped with the input and output three-phase connector, thus the AC input wires are recommended according to the three wires. Please notes that when the UPS is single phase input, the three fire wires need to be connected to the same phase of power input.

When 30kVA-40kVA UPS is set to 31 mode, bypass input and output wires are recommended as single wire. When the cross-sectional area of single wire is greater than 35mm², it is recommended to connect two wires in parallel.

Table3-3 Recommended cross-sectional area of wire (unit: mm², environment temperature:25°C)

type	10kVA			15kVA			20kVA		
	33	31	11	33	31	11	33	31	11
Mode type	33	31	11	33	31	11	33	31	11
AC input live wire (U/V/W)	4*3	4*3	4*3	6*3	6*3	6*3	10*3	10*3	10*3
AC input neutral wire (N)	4*1	10*1	10*1	6*1	16*1	16*1	10*1	16*1	16*1
Bypass input live wire (U/V/W)	4*3	10*1	10*1	6*3	16*1	16*1	10*3	16*1	16*1
AC output live wire (U/V/W)	4*3	10*1	10*1	6*3	16*1	16*1	10*3	16*1	16*1
AC output neutral wire (N)	4*1	10*1	10*1	6*1	16*1	16*1	10*1	16*1	16*1
DC input (+/BATN/-)	6*3	6*3	6*3	10*3	10*3	10*3	10*3	10*3	10*3
Grounding wire (PE)	6*1	6*1	6*1	10*1	10*1	10*1	10*1	10*1	10*1

Table3-4 Recommended cross-sectional area of wire (unit: mm², environment temperature: 25°C)

type	30kVA		40kVA	
	33 mode	31 mode	33 mode	31 mode
AC input live wire (U/V/W)	16*3	16*3	16*3	16*3
AC input neutral wire (N)	16*1	16*2 (parallel)	16*1	25*2 (parallel)
Bypass input live wire (U/V/W)	10*3	35*1	16*3	25*2 (parallel)
AC output live wire (U/V/W)	10*3	35*1	16*3	25*2 (parallel)
AC output neutral wire (N)	10*1	16*2 (parallel)	16*1	25*2 (parallel)
DC input (+/BATN/-)	16*3	16*3	25*3	25*3
Grounding wire (PE)	16*1	16*1	16*1	25*1

Table3-5 Contrast list between wires and wiring terminals

Wire cross-sectional area (unit: mm ²)	Wiring terminal type	
	Perforation	Straight cutting
4	RV3.5-6	/
6	RV5.5-6	/
10	RNBS8-6	E10-12
16	RNBS14-6	E16-12
25	RNBS22-6	E25-16
35	RNBS38-8	/

- 10kVA-20kVA UPS

The wiring terminals of 10kVA-20kVA UPS recommend type as shown in Table3-1. If users have additional terminals required, please check dimensions to ensure proper selection according to Table3-7.

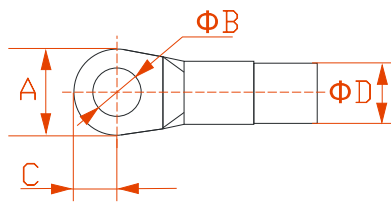

Figure3-1 Wiring terminal dimensions of 10 kVA-20kVA UPS

Table3-6 Dimensions limit of wiring terminal

Dimensions (unit: mm)	10kVA			15kVA			20kVA	
	4	6	10	6	10	16	10	16
A	≤12.1			≤12.1			≤12.1	
B	≥6.2			≥6.2			≥6.2	
C	≤6.2			≤6.2			≤6.2	
D	≤6.2	≤6.7	≤7.2	≤6.7	≤7.2	≤9.0	≤7.2	≤9.0

● 30kVA-40kVA UPS

Wiring terminal dimensions of the wiring terminals of 30kVA-40kVA UPS recommend type as shown in Figure3-2. If users have additional terminals required, please check dimensions to ensure proper selection according to Table3-7.

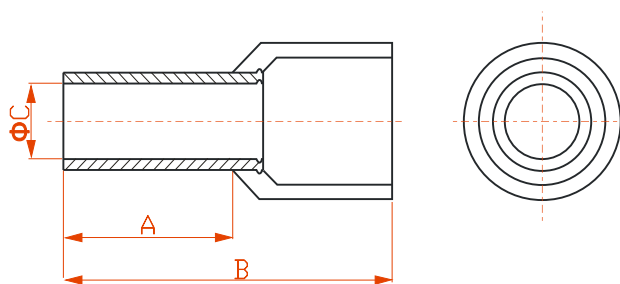

Figure3-2 Wiring terminal dimensions of 30 kVA-40kVA UPS

Table3-7 Dimensions limit of wiring terminal

Dimensions (unit: mm)	30kVA		40kVA	
	10	16	16	25
A	≤12.5	≤12.5	≤12.5	≤16.7

Dimensions (unit: mm)	30kVA		40kVA	
	10	16	16	25
B	≤24	≤24	≤24	≤29.4
C	4.7±0.3	5.83±0.3	5.83±0.3	7.43±0.3

When the 30kVA-40kVA UPS is set to 31mode, the terminal (as shown in Figure3-3) will be used, and its size requirements are shown in Table3-8.

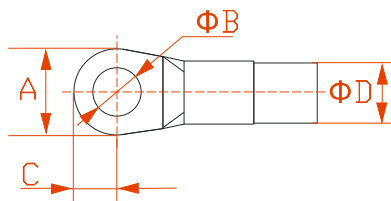

Figure3-3 Wiring terminal dimensions

Table3-8 Dimensions limit of wiring terminal

Mode	30kVA-40kVA	
	25	35
A	≤12.2	≤15.4
B	≥6.15	≥8.3
C	/	≤8.4
D	≤11.5	≤13.3

NOTE

The equipped wires by our company are all passed the national standard or UL certification, the quality is perfect and meets the requirements of safety standard. The cross-section area of the above cables is only a reference value or users connecting 5 meters long. If the length of the cable exceeds 20 meters, the cross-section of the wires will be increased accordingly

3.3 Mechanical Installation

The installation for the UPS can be tower-mounting and rack-mounting, user can select suitable installation way according to actual condition.

3.3.1 Tower-mounting

Single UPS installation

- Step 1 Take out a pair of support base and 1U joint base, assemble them together, as shown in Figure3-4, and lay them flat for the UPS tower base.

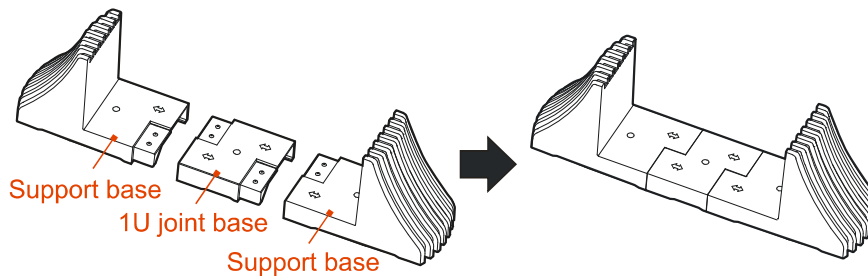

Figure3-4 Assemble support base

- Step 2 Put the UPS onto the assembled support base, as shown in Figure3-5.

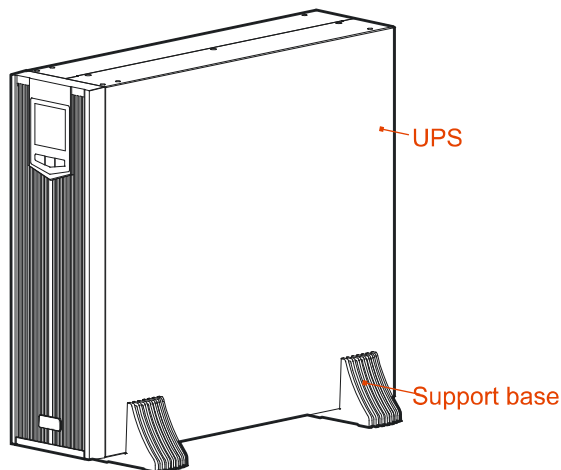

Figure3-5 Install the UPS

----End

Install the UPS with battery box or distribution module

When equip battery box or distribution module, the installation procedure is the same. In this section, we take the installation of one UPS and one distribution module as an example to illustrate.

- Step 1 Take out a pair of support base and other 1U joint bases, assemble them together, as shown in Figure3-6.

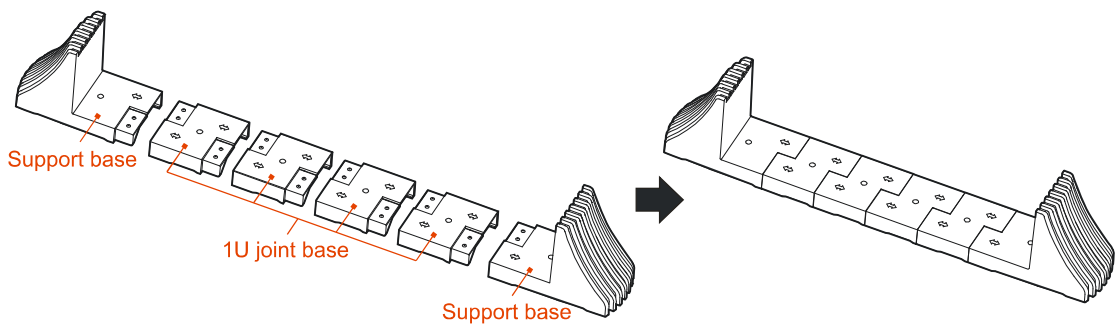

Figure3-6 Assemble support base

 **NOTE**

When one optional added, 3 pieces of 1U joint base need to add, the assemble way is the same.

Step 2 Put the UPS and distribution module onto the assembled support base, as shown in Figure3-7.

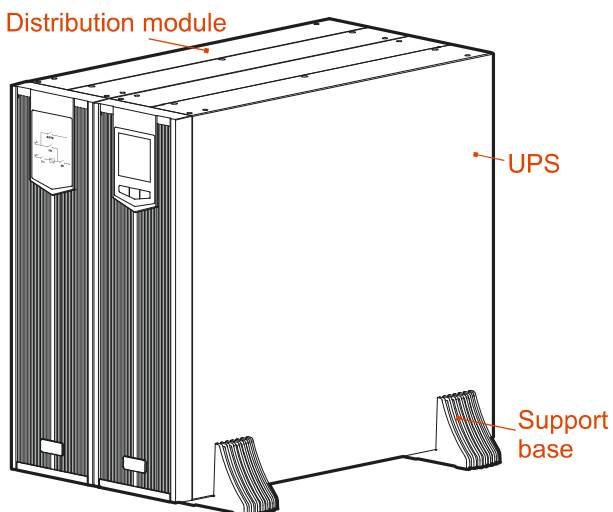

Figure3-7 Install the UPS and distribution module

Step 3 Take out the combination parts and screws, and fasten them onto the top of the UPS and distribution module, as shown in Figure3-8.

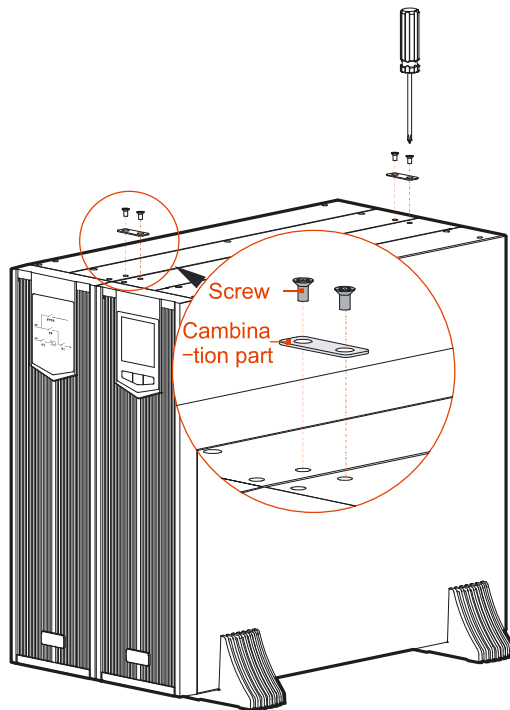

Figure3-8 Install combination units

**CAUTION**

Every two adjacent devices need to be connected by two combination parts at the top of the device, that is to say, every add one optional (distribution module or battery box), it needs to install another 2 combination parts.

----End

3.3.2 Rack-mounting

UPS and the optional also can be installed in 19 inch standard cabinet to use.

NOTE

The rack-mounting procedure of UPS, battery box and distribution module is the same, in this section, we take the UPS installation as an example to illustrate.

- Step 1 Fasten the two angle irons onto the two sides of the UPS by 4 sunk screws M4×8, as shown in Figure3-9.

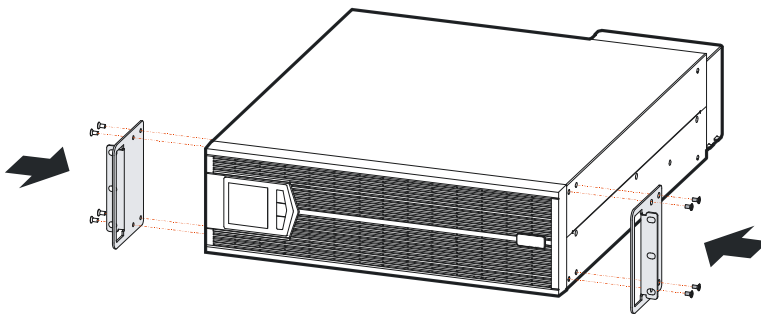

Figure3-9 Install angle iron



WARNING

Do not transport the UPS, battery box or power distribution module by angle iron.

The front panel can be dismantled front, during transporting, do not make it bear any force.

The device needs to be transported by two or more people.

Step 2 Push the UPS into the cabinet, and fasten it by screws, as shown in Figure3-10.

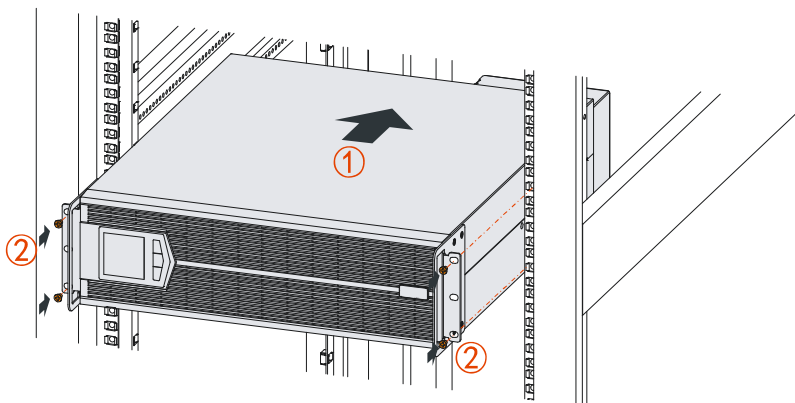

Figure3-10 Fasten the UPS



CAUTION

The battery box is heavy, when installing, the battery box must be installed from bottom and down below the UPS.

----End

3.4 Electrical Connection



WARNING

Before connecting, ensure that the external connected front breakers of mains, battery are all off. DO NOT connect wires with electricity.



CAUTION

While wiring, avoid making the power wire at the place where is easy to be trod or tripped.



NOTE

If there is an optional distribution module, the wiring of UPS and distribution module (optional) shall be connected with the distribution module wire first, and then the UPS wire.

3.4.1 Wiring Operation of 10kVA-20kVA UPS

33 mode

The input and output wiring of 33mode UPS is as shown in Figure3-11.

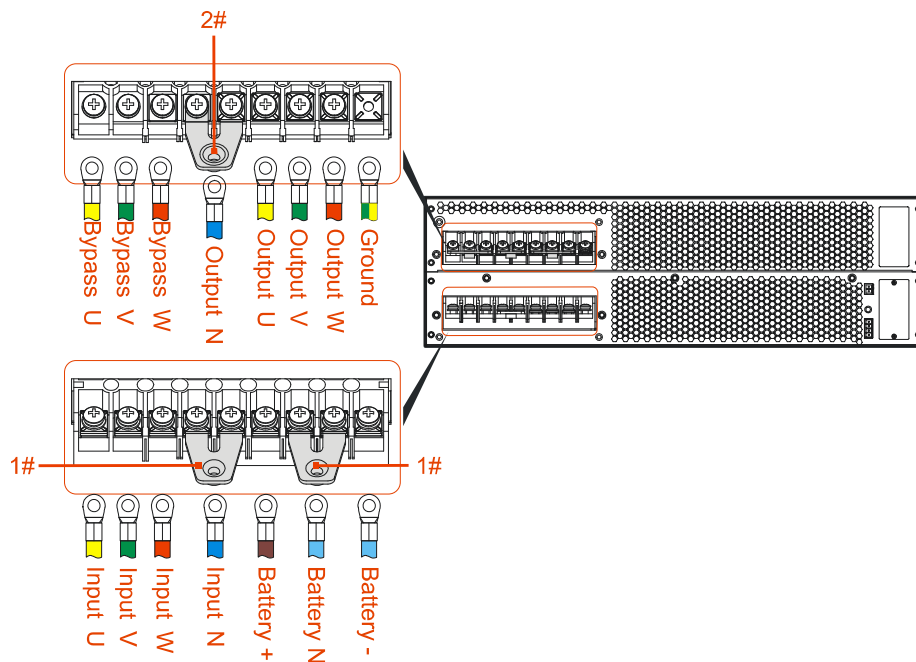

Figure3-11 The 33 mode wiring of 10kVA-20kVA UPS

31 mode

The input and output wiring of 33mode UPS is as shown in Figure3-12.

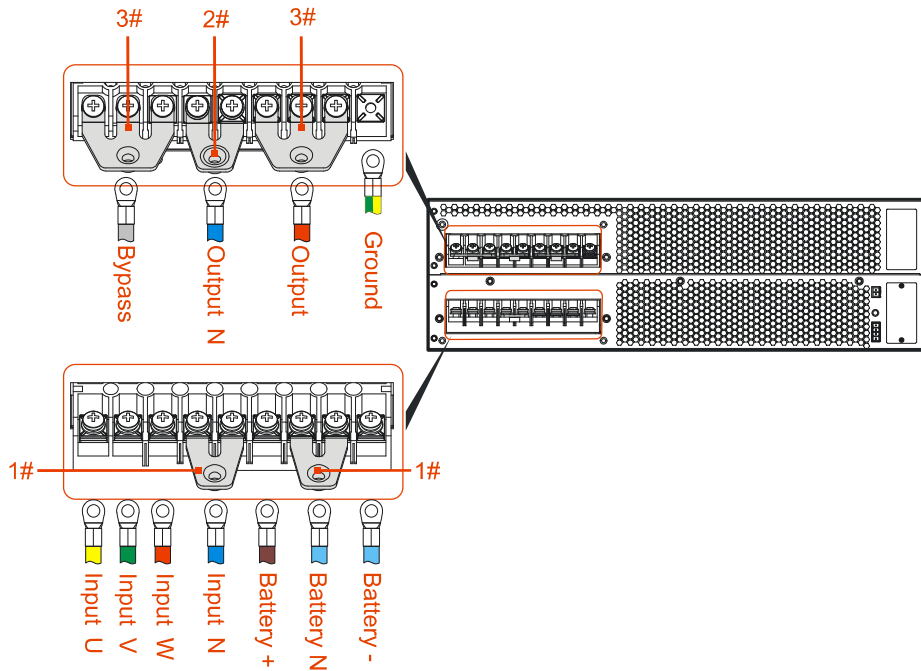

Figure3-12 The 31 mode wiring of 10kVA-20kVA UPS

3.4.2 Wiring Operation of 30kVA-40kVA UPS

33 mode

The input and output wiring of 33mode UPS is as shown in Figure3-13. The output and input have two N-terminal bar respectively, and they separate parallel connection. The input and output single cable of the 33 mode can be connected to one of the groups.

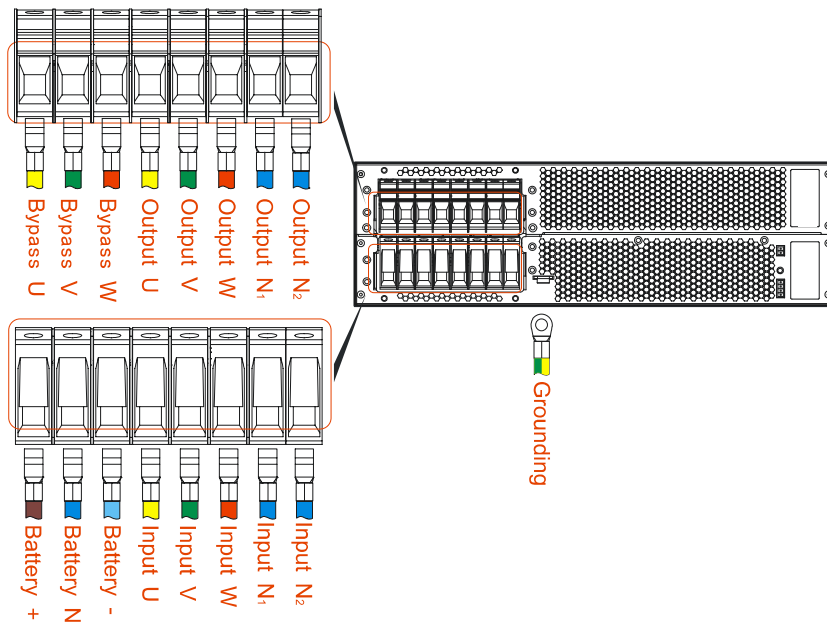

Figure3-13 The 33 mode wiring of 30kVA-40kVA UPS

31 mode

Take out a couple of copper bar 1#, connect them to the wiring terminal of UPS. The wiring diagram of 31 mode UPS is as shown in Figure 3-14. When the wire output and the input N wire are in parallel of two cables, the two groups of N-terminals are connected separately.

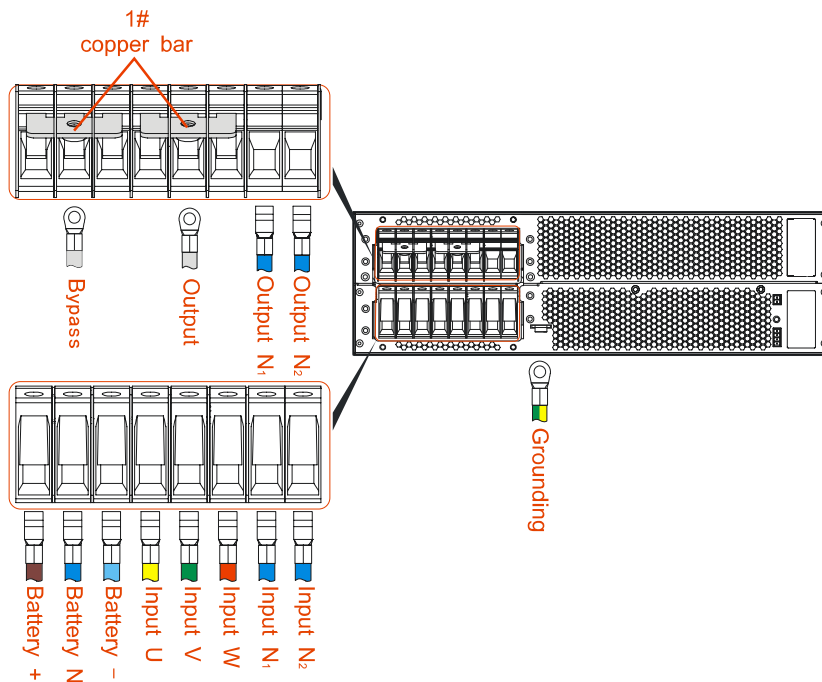
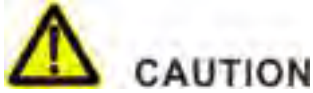

Figure3-14 The 31 mode wiring of 30kVA-40kVA UPS

3.4.3 Wiring Between UPS and Battery Box



DC battery switch must be provided between the battery and UPS.

User can select tower-mounting or rack-mounting the UPS according to use space. Specific installation requirements are as follows:

Rack-mounting products: UPS installed in the bottom layer, distribution module installed in the top layer for easy cable connection and operation.

Tower-mounting products: the distribution module is installed on the left side of UPS to facilitate cable connection and operation. The battery box is on the left side of distribution, as shown in Figure3-15.

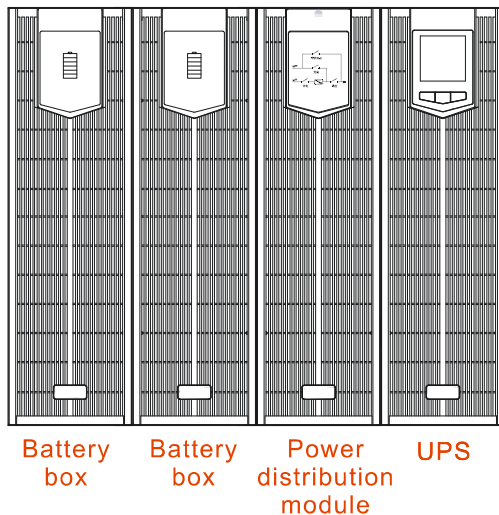

Figure3-15 Tower-mounting

3.4.4 Wiring Between UPS and Battery Box of 10kVA-20kVA UPS



The wiring of parallel connected battery box and each mode UPS is the same, in this section, we take 20kVA as an example to illustrate.

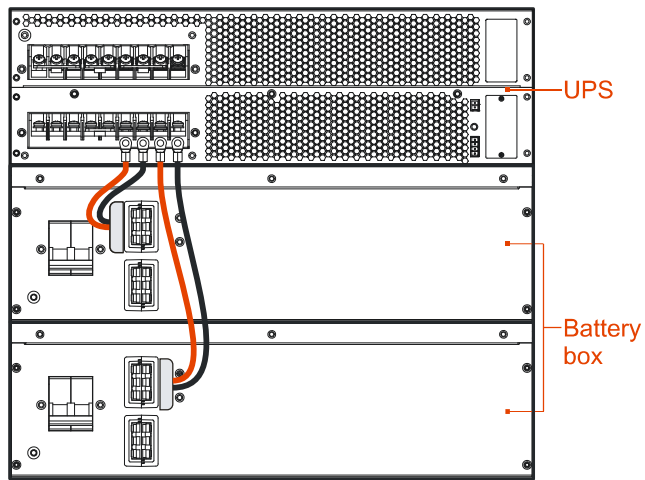

Figure3-16 Wiring diagram between UPS and two parallel connected battery boxes

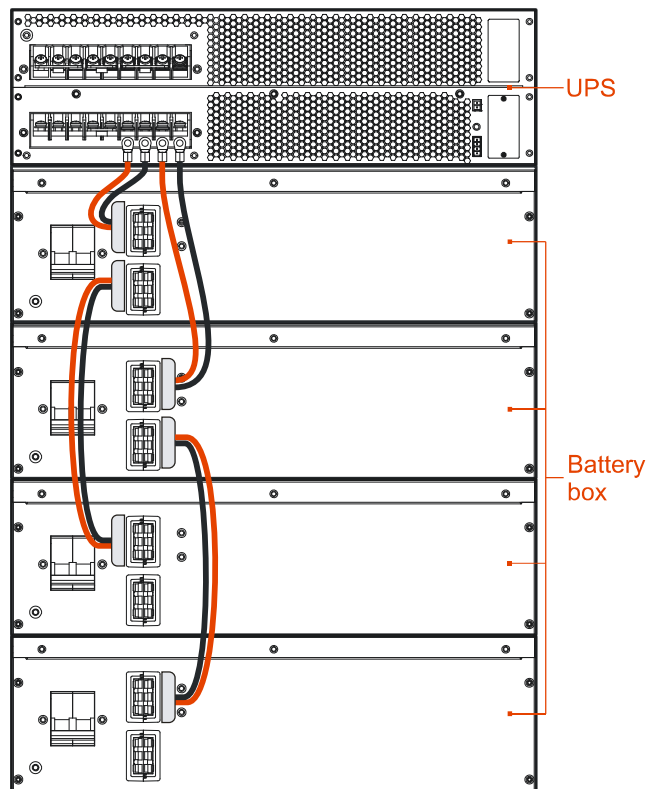

Figure3-17 Wiring diagram between UPS and two sets parallel connected battery boxes (each set has two battery boxes)



WARNING

The wiring between UPS and parallel connected battery boxes must be connected strictly according to Figure3-16, Figure3-17, avoid wrong connection or short circuit.

3.4.5 Wiring Between UPS and Battery Box of 30kVA-40kVA UPS

NOTE

The wiring of parallel connected battery box and each mode UPS is the same, in this section, we take 40kVA as an example to illustrate.

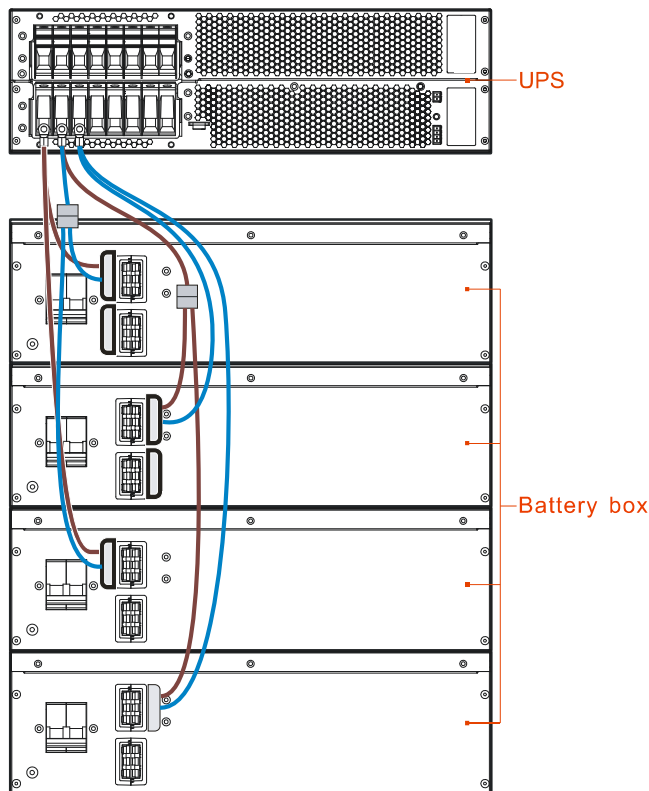

Figure3-18 Wiring diagram between UPS and two sets parallel connected battery boxes (each set has two battery boxes)



WARNING

The wiring between UPS and parallel connected battery boxes must be connected strictly according to Figure3-18, avoid wrong connection or short circuit.

Wiring of external batteries

If user needs to connect batteries externally, please connect the wires as follows.

This series UPS's battery input adapt positive and negative battery group (each battery group default has 16 positive cell and 16 negative cell). Figure3-19 shows one wiring way: one battery cabinet has 32 cells and one 3P breaker, the external wiring includes BATT.+, BATT.- and battery neutral wire. The selection of battery wires and breaker specification please see Table3-2, Table3-3 and Table3-4.

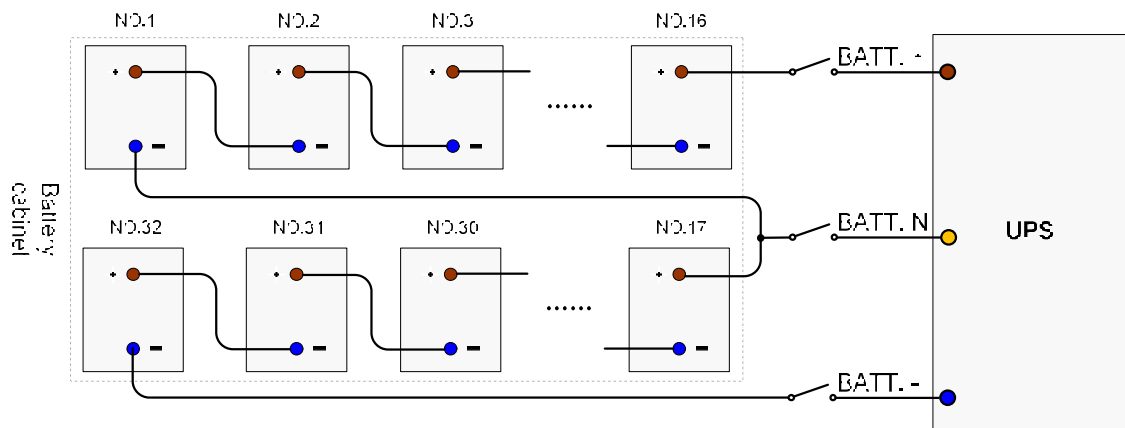

Figure3-19 Wiring diagram of external batteries

3.4.6 Wiring Between UPS and Distribution Module of 10kVA-20kVA UPS

Wiring of each standard UPS and distribution module is shown in Figure3-20 and Figure3-21.

33 mode

The supporting UPS and the distribution wire are connected one to one according to the wire information.

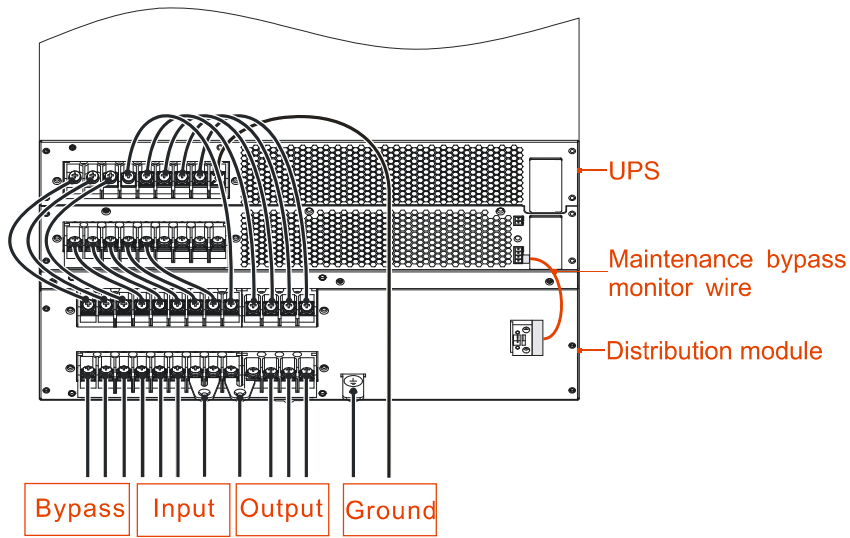

Figure3-20 Wiring Between 33 mode UPS and Distribution Module of 10kVA-20kVA UPS

31 mode

The copper bar from Table2-2 are short connect with 3P terminal bar of the bypass and output. The supporting UPS and the distribution wire are connected one to one according to the wire information.

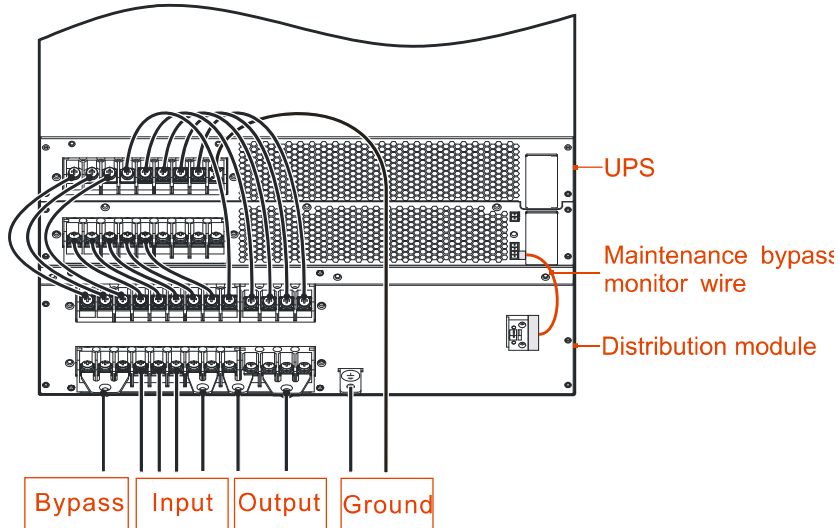

Figure3-21 Wiring Between 31 mode UPS and Distribution Module of 10kVA-20kVA UPS

**CAUTION**

Ensure that the wires are connected properly and firmly, and then install the wiring protection plate to the device (the installation procedure is as follows).

3.4.7 Wiring Between UPS and Distribution Module of 30kVA-40kVA UPS

Wiring of each standard UPS and distribution module is shown in Figure3-22andFigure3-23.

33 mode

The supporting UPS and the distribution wire are connected one to one according to the wire information.

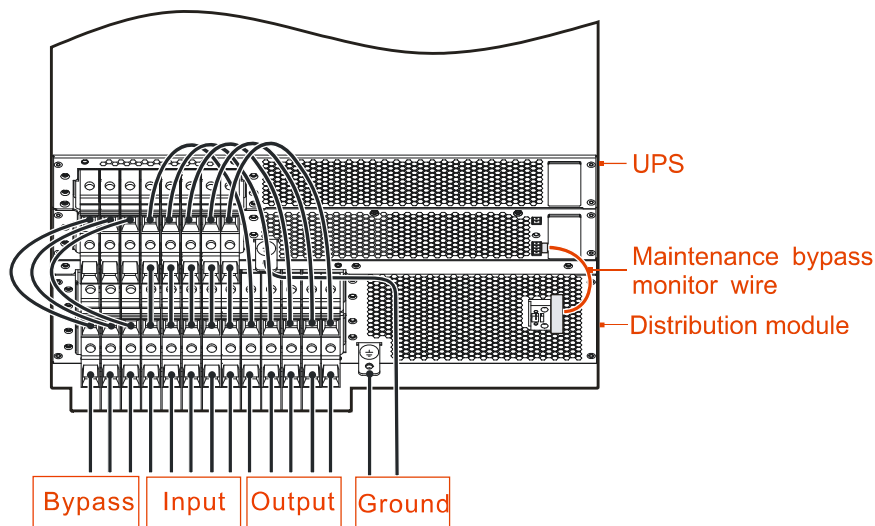

Figure3-22 Wiring Between 33 mode UPS and Distribution Module of 30kVA-40kVA UPS

31 mode

The 2# copper bar from Table2-3 are short connect with 3 pin terminal bar of the bypass and output. The supporting UPS and the distribution wire are connected one to one according to the wire information.

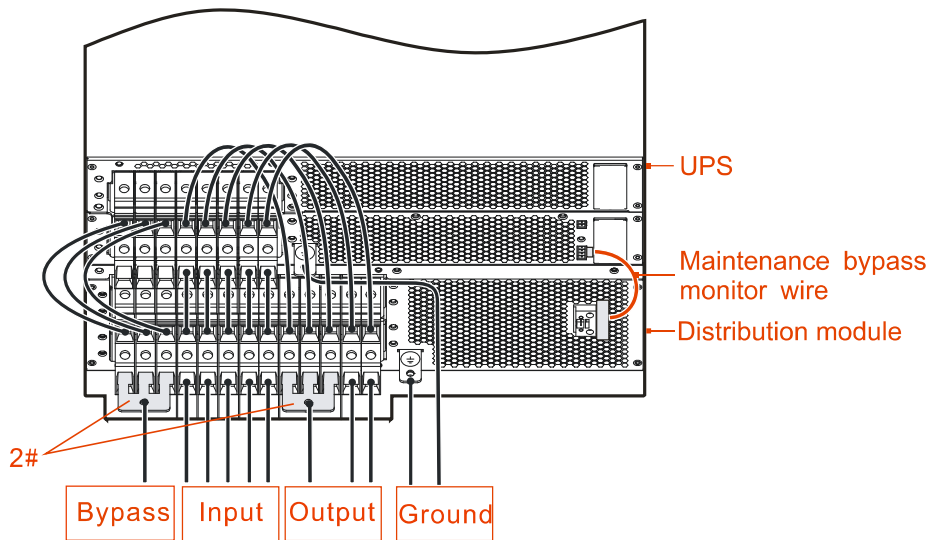

Figure3-23 Wiring Between 31 mode UPS and Distribution Module of 30kVA-40kVA UPS



CAUTION

Ensure that the wires are connected properly and firmly, and then install the wiring protection plate to the device (the installation procedure is as follows).

Install wiring plates



NOTE

The wiring covers' install procedure of each mode UPS and distribution module is the same, in this section, we take 40kVA as an example to illustrate.

Step 1 Remove the flat-head screws from the protective cover before wiring, as shown inFigure3-24.

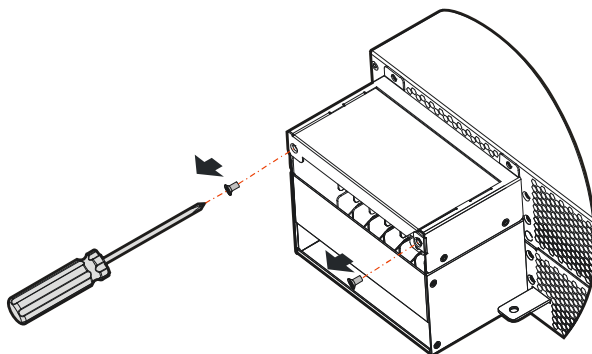

Figure3-24 Remove the screws from the protective cover

Step 2 Remove the protective cover, as shown in Figure3-25.

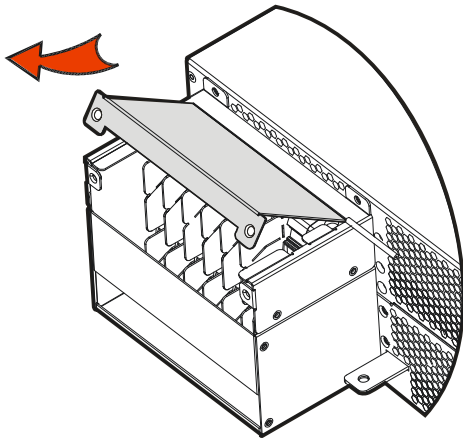

Figure3-25 Remove the protective cover

Step 3 Connect the wires in accordance with 3.4.1 Wiring Operation as shown in Figure3-26.

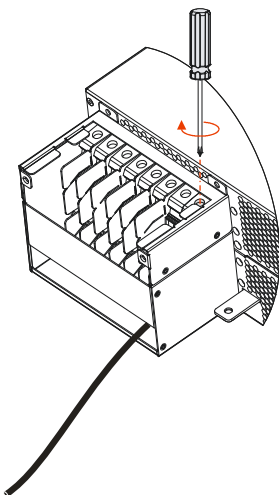

Figure3-26 Connect the wires

Step 4 Reinstall the wiring row cover in the corresponding position of the chassis, as shown in Figure3-27.

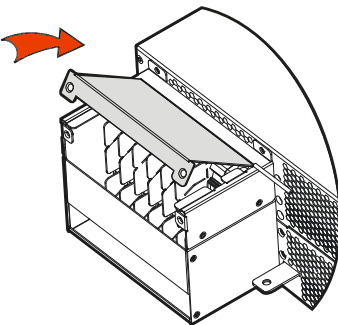

Figure3-27 Reinstall the wiring row cover

Step 5 Fix with the flat head screws, as shown in Figure3-28.

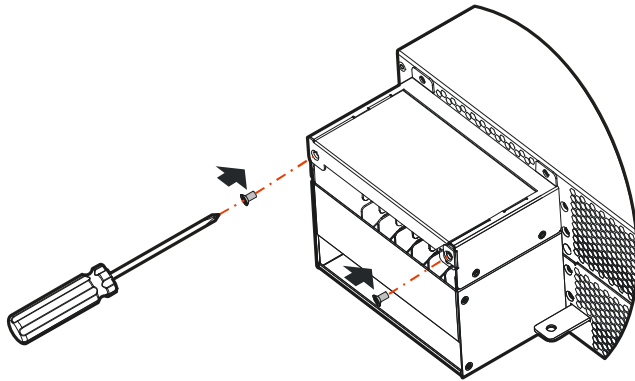

Figure3-28 Fix with the flat head screws

----End

3.4.8 Wiring of Parallel System

Step 1 Install the battery and UPS of parallel system separately according to **3.3 Mechanical Installation**.

Step 2 Connect the wires of input, output, battery and grounding in parallel system on the basis of Figure3-29, Figure3-30, Figure3-31 or Figure3-32.

- 10kVA-20kVA

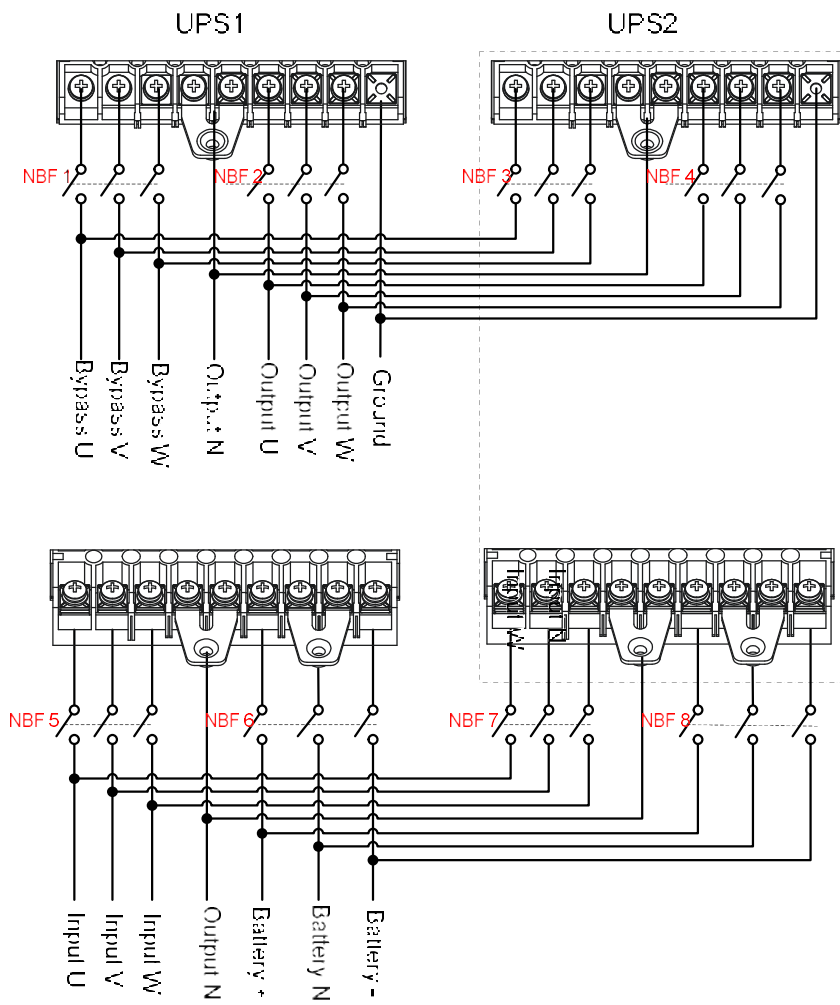

Figure3-29 Diagram of 33 mode parallel system wiring of 10kVA-20kVA UPS

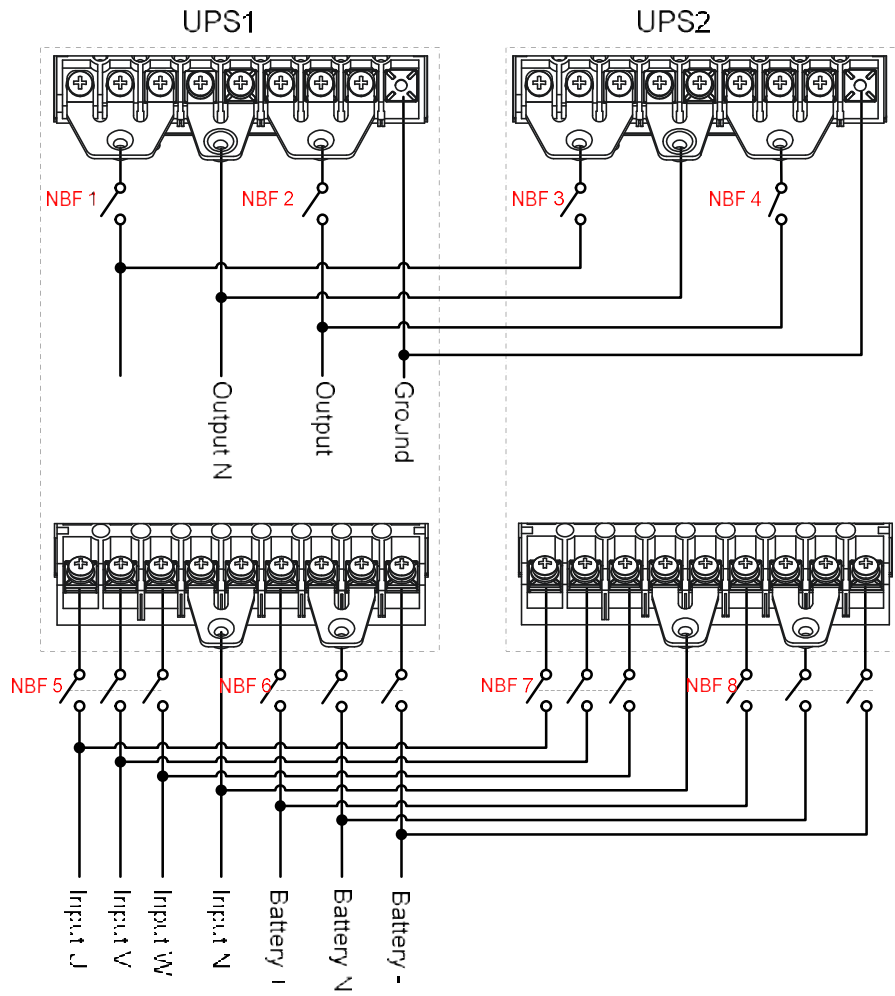

Figure3-30 Diagram of 31 mode parallel system wiring of 10kVA-20kVA UPS

- 30kVA-40kVA

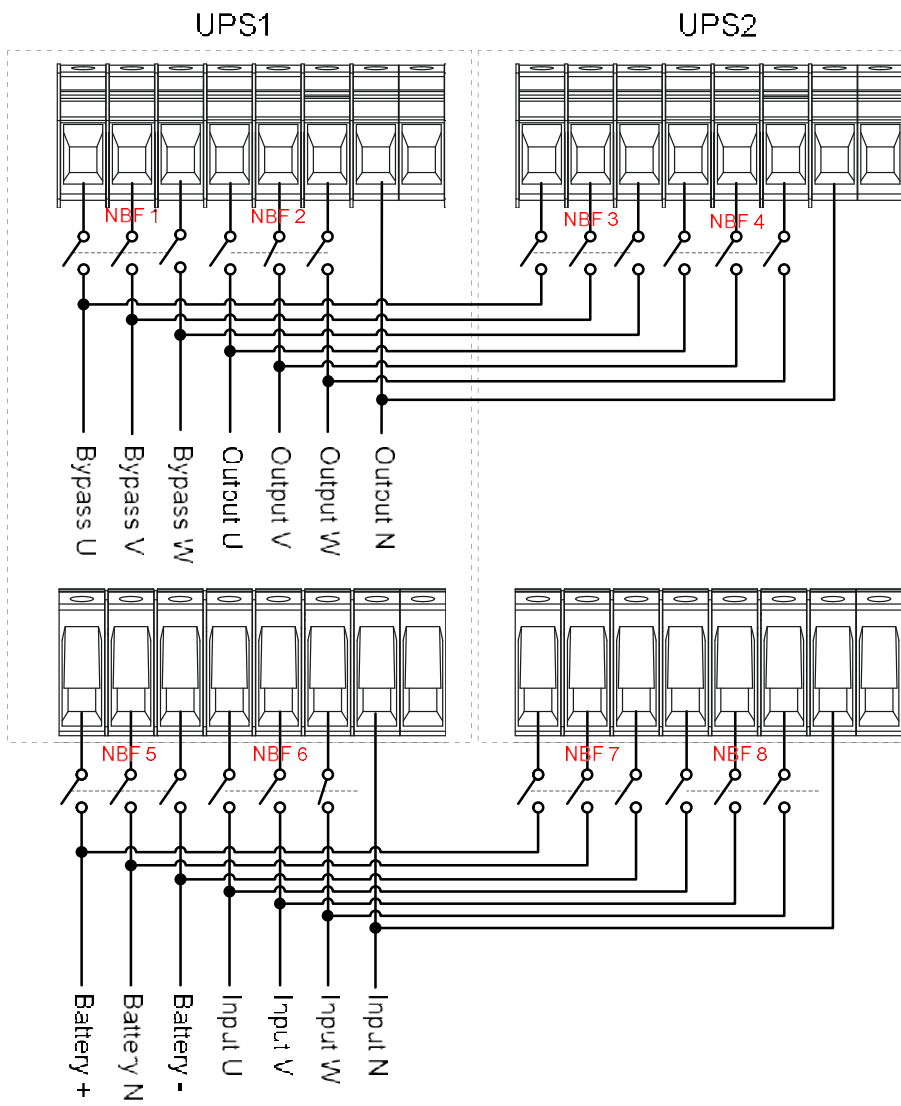

Figure3-31 Diagram of 33 mode parallel system wiring of 30kVA-40kVA UPS

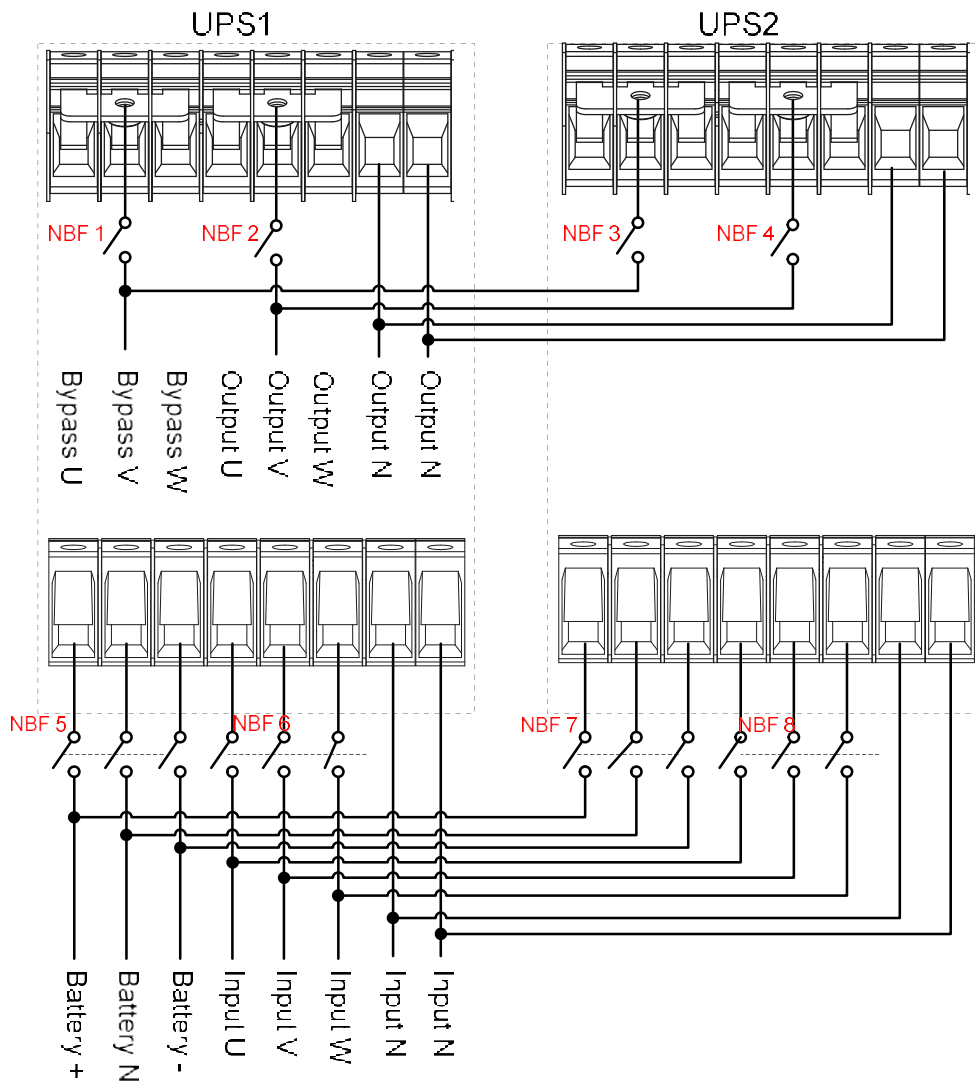

Figure3-32 Diagram of 31 mode parallel system wiring of 30kVA-40kVA UPS

Step 3 Connect the parallel port of each unit in parallel by parallel wires, as shown in Figure3-33.

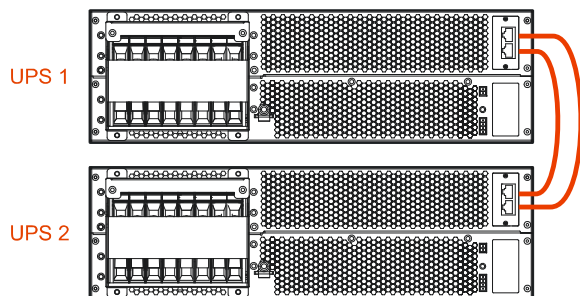

Figure3-33 Wiring diagram of parallel wire

 **NOTE**

1. The wiring of parallel port of each mode UPS is the same, in above figure, we take 30kVA as an example to illustrate.
2. The UPS parallel system requires the user to distribute power by himself.



CAUTION

1. The wiring and phase sequence of each unit in the parallel system must be the same strictly, which is to ensure the bypass power of parallel system is the same phase.
 2. The parallel system of this series UPS can share battery groups, but the battery amount of each UPS must be the same.
 3. Connect the parallel ports of each unit in parallel by equipped shielding communication wire. The two RJ45 parallel ports are the same, they are redundancies and backup for each other to increase the reliability of the system, once one of them is not connected, the UPS will send alarm prompting.
-

----End

4 Screen Operation

This chapter mainly introduces the working parameters, working status and system settings of UPS screen.

4.1 Menu Hierarchy

The menu hierarchy of the screen is as shown in Figure4-1.

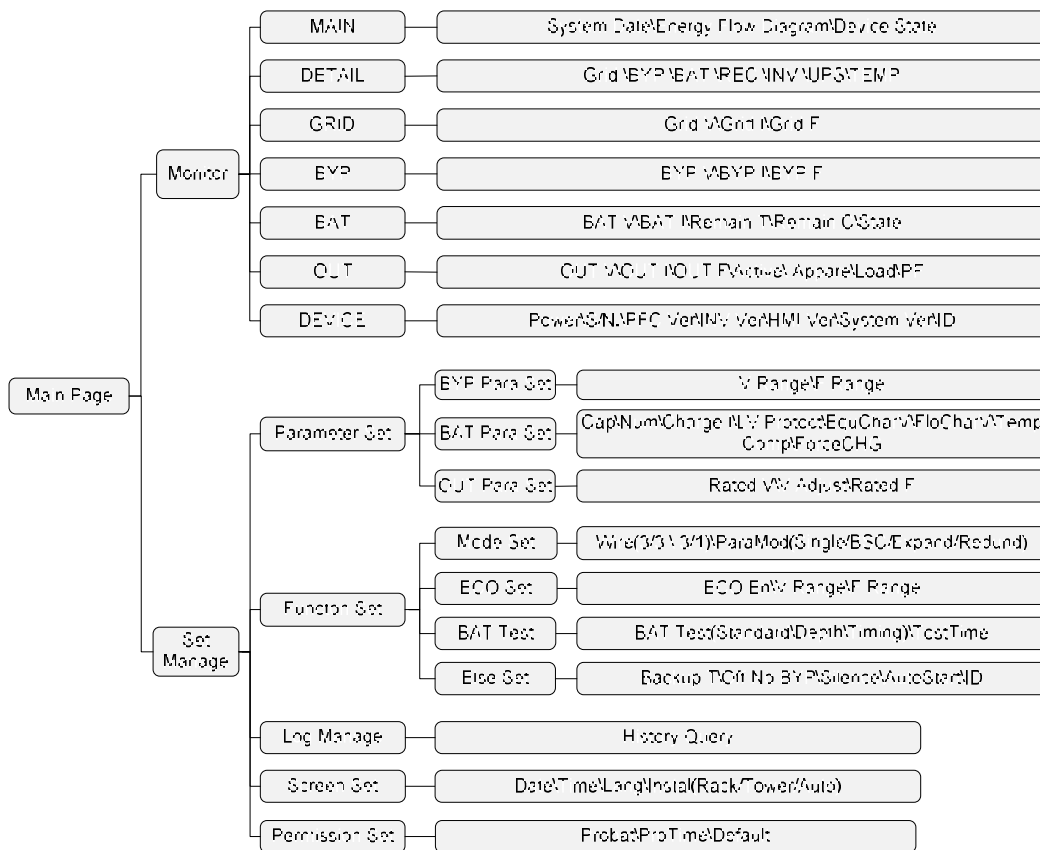

Figure4-1 Menu hierarchy of the screen

NOTE

The parameter values and other details in the pictures in this chapter are for illustration only. The actual parameters should be displayed on the LCD of the product.

4.2 Power On for The First time

After power on, the system will enter the welcome page first. If the UPS is started for the first time, the welcome page will stay 5s after entering the password input page, as shown in Figure4-2.



Figure4-2 password input page

NOTE

Each series of the UPS is different, the Figure4-2 just for an example, the actual displayed should be based on the LCD of the product.

User needs to input the password correctly before continuing to use it.

Please contact the local customer service, report the machine serial number on the LCD, you can get the boot password.

After entering the password, press the function button shortly, if the power-on password is correct, then go to the monitoring main page, if the password is wrong, the screen will have the word "password error" display. Password match successfully after long-term validity, subsequent use does not need to be entered again.

4.3 Main Page

After the UPS is powered on, it will enter the system monitoring main interface-energy flow chart display page, as shown in Figure4-3.





Figure4-3 Main Page

After entering the main interface, it is easy to monitor the system. The meaning of the icons on the main interface is as follows:

: System bypass icon.

: System rectification icon.

: System inverter icon.

: System battery icon. The internal energy bar of the battery changes accordingly depending on the current battery status and battery voltage.

: System current date display.

: System current operating status display.

: Monitor page number display.

The working state and energy flow on the main interface visually describe the operating state of the system and the operation of the module.

4.4 System Working Status Display

The operating status of the system is: main power inverter output, battery inverter output, ECO bypass output, maintenance bypass output. Interface display for each working status as shown in Figure4-4 to Figure4-7.



Figure4-4 Main power Inverter Output



Figure4-5 Battery Inverter Output



Figure4-6 ECO/Bypass output



Figure4-7 Maintenance bypass output

4.5 Monitoring Page

After the system automatically enters the monitoring page, the monitoring page in the lower right corner has page number display, according to the current set of different system, the total number of monitoring pages displayed is different. By pressing the up/down page button, you can turn on the monitoring page, and the monitoring page loop display, three-in and three-out page number and page loop order as shown in Figure4-8.

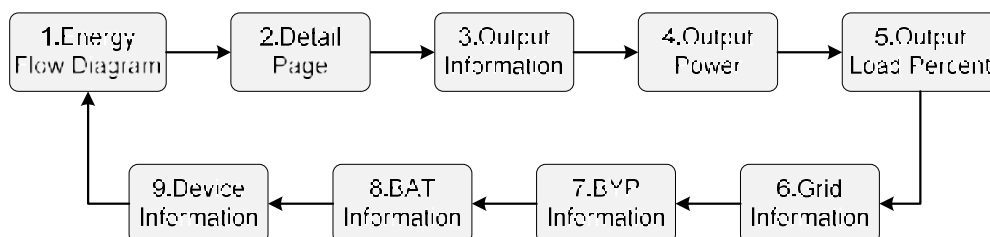

Figure4-8 three-in and three-out page number and page loop order

4.6 Setting Page

On the monitoring page, by long pressing function button for 3s, you can go to the settings page. And the setting page structure diagram as shown in Figure4-9. In the settings page, by short pressing the up/down page button, you can realize the function of selecting up/down scrolling, and then with the function button short press and short press function, you can realize the setting function of the corresponding setting item. Besides, setting the lower right corner of the page has a return button, by short pressing the up/down page button and with the function button short press function, you can achieve the function of returning to the previous page.

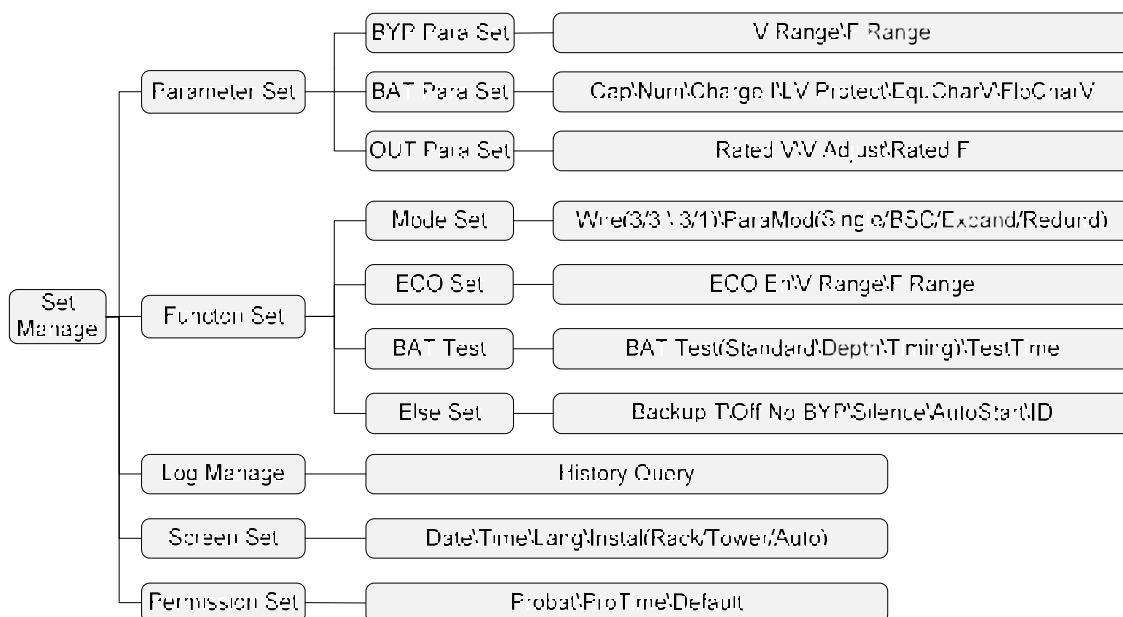

Figure 4-9 Setting page structure diagram

4.7 Management Setting

In any monitoring page by long pressing function button for 3s can enter the settings management page, the page is mainly for the directory display function, the page display includes: parameter set, function set, log manage, screen set and permission set five items, as shown in Figure 4-10. Each item has a hollow box icon "□" before it, and if the item is selected, the hollow box icon becomes a solid box "■" icon. You can select page content by pressing the up/down page button. When you select the back button "←" to the lower right corner, the back button is selected and appears as opposite color status "←".



Figure 4-10 Set manage page

After the page option selection is complete, short press the function button to go to the corresponding next settings page. When you select the back button "←" in the settings

management page and press the function button shortly, the display takes you to the previous page.

4.7.1 Parameter Setting

In the settings management page, select the "Parameter Set" option, and short press the function button shortly to enter the parameter settings page, which is a second class page, mainly for the directory display function, the page display includes: bypass parameter settings, battery parameter settings and output parameter setting three, as shown in Figure4-11 and Figure4-12.



Figure4-11 Parameter setting page

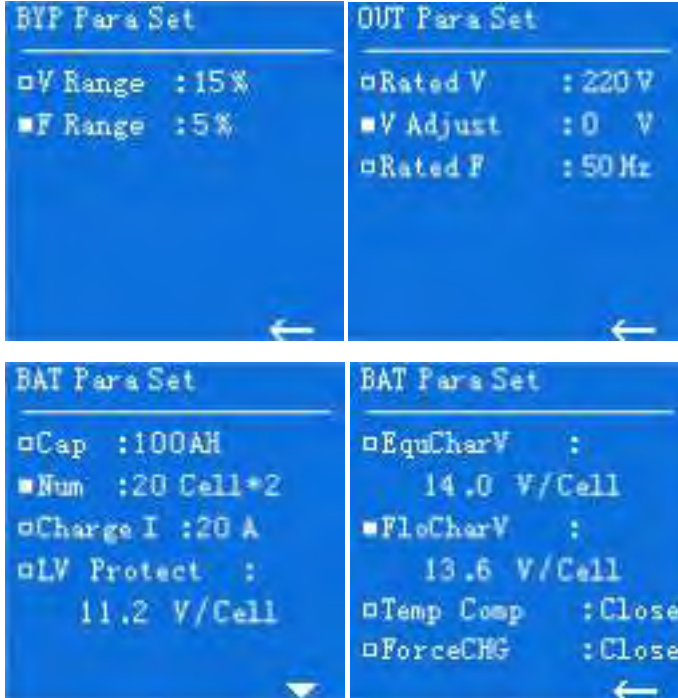

Figure4-12 Details of parameter setting page

By shortly pressing the up/down page button to achieve the page option selection, the selected option in front of the hollow box will become a solid box, at this time short press

function button can go to the corresponding next level of settings page. When you select the back button at the lower right corner, the return button is displayed as opposite color state, and this time, short press function button can go to the previous level of the page, and the previews class parameter settings page is the settings management page.

There are four next level pages on the parameter settings page, one bypass parameter settings page, two battery parameter settings pages, and one output parameter settings page. In the battery parameter page, you can select the setting options by short pressing the up/down page turning button. After the option selection is complete, such as selecting "number of sections", you can enter the setting of the number of sections by short pressing the function button, the number of sections displayed "20" will flash, and this time, you can set the section number minus/plus by pressing the up/down page turning button. When the section number is adjusted to the value to be set, the section number setting can be completed by the short function button.

4.7.2 Function Setting

In the Settings Management page, select the "Function Set" option, and short press the function button to enter the function settings page, and it mainly for the directory display function, the page display includes: mode set, ECO set, battery test and else set four items, as shown in Figure4-13.

By shortly pressing the up/down page button to achieve the page option selection, the selected option in front of the hollow box will become a solid box, at this time short press function button can go to the corresponding next level of settings page. When you select the back button in the lower right corner, the return button is displayed as opposite color state, at which point the short press function button can go to the previous level of the page, and the previews class function settings page is the settings management page.



Figure4-13 Function setting page

There are four next-level pages on the function set page, and the page display includes: mode set, ECO set, battery test and else set four items, as shown in Figure4-14.

The following is to take the battery test page as an example, explain the three-level page setting method, the rest of the page setting method is the same, will not repeat the story.

On the battery test page, you can select the options by short pressing the up/down page button, and after selecting "Standard Test", you can enter the settings for the standard test by short pressing the function button, at which point the standard test option "Off" flashes;

The on/off option switch can be performed for the standard test, and after adjusting to the specific option, the standard test can be completed by short pressing the function button.

Because the current three battery tests cannot be performed at the same time, when one battery test is set to on, the options for the other two battery tests automatically appear to be off. In addition, since the discharge time setting is only available under the timing test conditions, when the timing test is set to off, the discharge time item is not displayed.

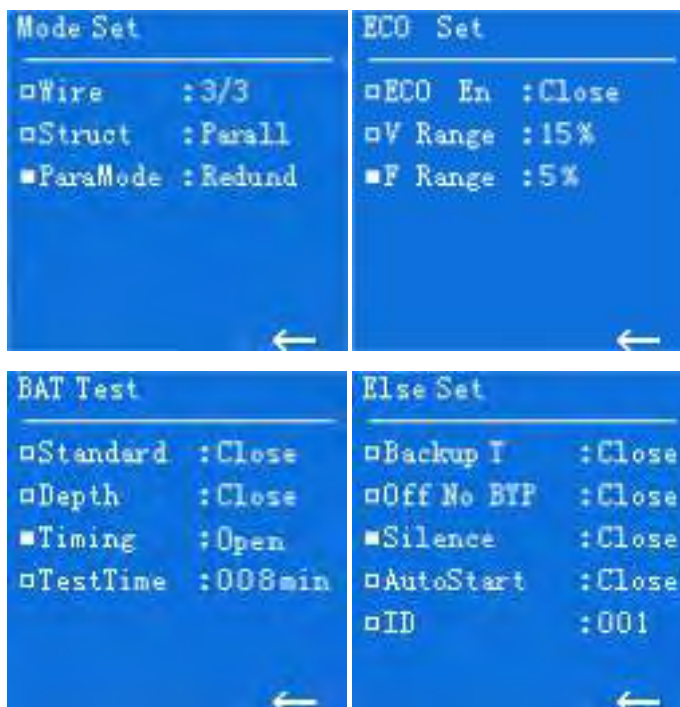

Figure4-14 Details of function setting page

 **NOTE**

1. Battery test settings: Standard test is that UPS return to the electrolytic inversion after turning to battery inverter for 10s at power-on state, and the depth test is that UPS to go to battery inversion until the battery discharges to the under-voltage alarm, and then returns to the main power inverter.

2. Back-up time display settings: When there are other more accurate battery remaining discharge time monitoring devices in the system, you can choose to turn off the battery residual discharge time display function of the UPS itself.
3. Call self-start setting: manual mode is that human shutdown needs to be re-manual power edged to trigger the UPS self-start function after the power generation, automatic mode is as long as the normal power generation UPS is self-starting, under this condition UPS shutdown can only be manually shut down when the battery is reversed, suitable for unattended applications.

4.7.3 Screen Setting

In the Settings management page, select the "Screen Settings" option, and short press the function button to enter the screen settings page, the page is a three-level page, the page display includes: date settings, time settings, language settings, display mode settings four items, as shown in Figure4-15.

The page option selection can be achieved by pressing the top/bottom page button shortly, and the hollow box in front of the selected option becomes a solid box. When you select the back button in the lower right corner, the back button is displayed as a opposite color state, at which point the short press function button can go to the next level of the page, and the previous level page on the screen settings page is the settings management page.

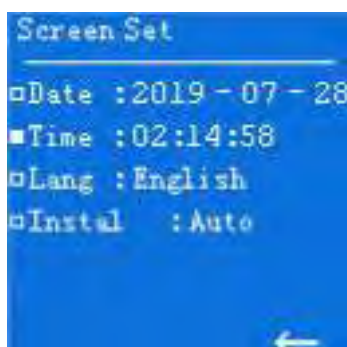

Figure4-15 Screen set page

On the screen settings page, select "Date" and short press the settings button will enter the date settings, where "2019" in the date will flash, and when flashing, you can set the section number minus/plus by pressing the up/down page turning button. After the section number is adjusted to the value to be set, you can short press the function button to enter the month setting in the date. When entering the month setting, the value "07" corresponding to the month will flash, user can set the month number minus/plus by short pressing the up/down page turning button when the month is flashing, short press function button to enter the day setting in the date after adjusting the month number to the corresponding number. The same is true, when entering the day setting, the value "28" corresponding to the day will flash, user can set the day number minus/plus by short pressing the up/down page turning button when

the day is flashing, short press function button to finish the date setting after adjusting the day number to the corresponding number.

The time setting, language settings are the same as the date settings, and it will not be repeated here. The installation method settings have three options: tower, rack and automatic, and when set to Auto, the LCD screen automatically switches the display mode based on the current UPS placement status (tower type or rack type).

4.7.4 Permission Setting

In the Settings management page, select "Permission" option to enter the password entry page first, as shown in Figure4-16.



Figure4-16 Password input page

By short pressing the up/down page button to achieve page option selection, when selecting the lower right corner of the back button, the return button will be displayed as a opposite color state, at this time short press function button can enter the page to the previews level of the page, the password input page on the previews level of the page for the settings management page.

In the password input page, short press function button can enter the password settings, at this time the first password flickering from the left, by short press the up/down page button can achieve the first bit password value minus/plus operation, select the required value, then short press function button into the second bit password settings. The second to sixth bit password is set the same way, which is not repeated here. The password input range is 000000-999999.

After the sixth bit passwords is entered, press the function button shortly, at which point if the password entered does not match the current system password, the screen will display the word "password error", and if the password entered matches the current system password, the system will enter the permission set page according to the current input password permission.



Figure4-17 Permission setting page

The permission set page includes trial function and trial time two setting items, and the trial time will not be displayed until the trial function is turned on. By pressing the up/down page button and working with the function button's short press operation, you can set the trial function and the trial time, the setting method is the same as the other settings mentioned above, and it is not repeated here.

 **NOTE**

1. The permission set is a restricted operation, if you need this operation, you need to obtain the trial period password from the service provider;
2. The way for obtain the trial period password: After the service provider agrees, report the series number on the password input page (as shown in Figure4-16), then you can obtain the corresponding passwords.

5 Use and Operation

This chapter mainly describes the operation process, operation method, daily maintenance and troubleshooting, etc.

5.1 Check Before Startup

- Check if the wire connection is firm and the color of AC wires is in accordance with the specification.
- Check if UPS is grounded reliably.
- Check if the voltage between the neutral wire and grounding wire is less than 5Vac.
- If the UPS equipped with remote monitoring device, check if the wiring of the RS485 port is correct.
- If it is long backup model, check if the wiring between UPS and battery box is correct and reliable.
- Check if the wiring is neat and the wire binding is in accordance with the specification.
- Check if the installation and wiring are good for transformation, expansion and maintenance in future.
- Check that there is no short-circuit in the output of the UPS and the load capacity isn't beyond the rated capacity of the UPS.

5.2 Startup Operation

- Step 1 Switch on the external mains, bypass and battery switch.
- Step 2 Press the "□" and ">" button on the front panel at the same time for 1s to start the UPS.
- Step 3 About 10s later, if the UPS works steadily, start loads, such as PC, etc.

**CAUTION**

Start load according to "high power device→small power device", which is to avoid overload protection when starting high power device.

----End

5.3 Shutdown Operation

- Step 1 Close load and keep the UPS running without load for about 10min to exhaust heat.
- Step 2 Press "□" and "<" button on the front panel at the same time for 1s to shut down the UPS.
- Step 3 Switch off the external battery, bypass and mains switch.

----End

5.4 Parallel System Operation

5.4.1 Start Parallel System

**CAUTION**

Before completely starting the parallel system, please do not start load, and ensure that all switches of output distribution cabinet are off.

The following steps for start the parallel system:

- Step 1 Ensure that each unit of parallel system is installed properly, start each unit of parallel system according to the **5.2 Startup Operation** one by one.
- Step 2 After each unit in parallel system outputs by inverter, measure the inverter voltage of each paralleled unit. The voltage difference between max. and min. voltage should be within 8V. Close the breaker of paralleled unit in parallel distribution cabinet, measure the circulating current of parallel unit, and the current should be less than 3A.

When the voltage different larger than 8V, measure the output voltage of the UPS and check if the output are all 220V, if the voltage different larger than 15V, please report it to our company to maintain it. In addition, once the circulating current of parallel unit too large, it will

lead to the inverter fault. If the circulating current larger than 3A, please report it to our company to maintain it.

- Step 3 Switch on the total output breaker of output distribution cabinet, each output branch breaker, and then start the load one by one.

----End

5.4.2 Shut Down Parallel System

Generally, it isn't recommended to start or close parallel system frequently.

- Step 1 Shut down all load.
- Step 2 Shut down parallel UPS one by one.
- Step 3 Switch off the related breakers of each unit (when daily use, the breakers can be not closed).

----End

5.4.3 Exit Parallel System Online

When one UPS in parallel system fault, it will exit from parallel system automatically with sound & light alarm. At that time, perform the operations shown in Figure5-1, the fault UPS will be exited from parallel system completely to achieve online hot maintenance or replacement.

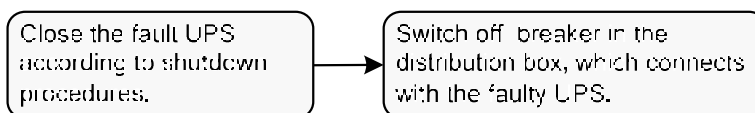

Figure5-1 Exit parallel system online



CAUTION

When the parallel system works normally, it's better not to exit the output from parallel system before the unit closed, or the power system will be abnormal.

5.4.4 Add New UPS into Parallel System Online

When it has to add one or more UPS into parallel system, perform the operations shown in Figure5-2. When the added UPS works steadily, it will add into parallel system automatically and achieve current- sharing.

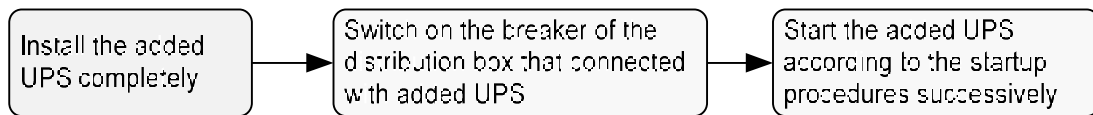

Figure5-2 Add new UPS into parallel system

5.4.5 Redundance Function of Parallel System

When system adopts N+1 redundance design, the total output cannot larger than N times of single unit's rated power. When one paralleled unit fault, it can put into use or exit parallel system and do not affect the operation of system, which enhance the system reliability. When output exceed N times of single unit's rated power, the overload unit (exceeding $N/(N+1)$ times of single unit's rated power) will send alarm. for example, for the backup system with two UPS, once one UPS overload for 50% rated power, it will send overload alarm.

5.5 Periodic Preventative Maintenance

To improve the efficiency and reliability of the UPS, perform the following maintenance regularly:

- Clean the UPS by dry cloth regularly. Don't use liquid or spray cleaner. Before cleaning, shut down the UPS.
- Check if the wiring of input and output is firmly and well connected.
- Check the working status of cooling fans regularly. Prevent sundries from blocking the air outlet. If damaged, please replace it in time.
- Check the battery voltage and the working status of UPS regularly to discover fault timely.

5.6 Battery Maintenance

The working life of battery is based on the environment temperature and discharge times. Using battery in the high temperature for a long time or discharging battery deeply will reduce the working life of battery.

When selecting battery box, please pay attention to following items:

- Charge the battery for 10 hours before using. During charging, the UPS still can be used, but if power outage at the same time, the discharging time may be less than the standard backup time.

- Generally, charge and discharge the battery once every 4 to 6 months. Discharge the battery till under-voltage and power off and then charge it. In high temperature area, charge and discharge the battery once every 2 months. The charging time for the standard battery should be more than 10 hours every time.
- If the UPS hasn't been used for a long time, it is recommended to charge the battery more than 10 hours every three months.
- Generally, the working life of battery is 3 to 5 years. If battery is not so good, replace it in time. The battery replacement should be performed by authorized professional.

5.7 Troubleshooting

5.7.1 Common Fault

As shown in Table5-1, it only includes some common fault diagnosis. If any doubt, contact the local office or distributor for details.

Table5-1 Troubleshooting

Fault phenomenon	Possible reason
The mains normal, after starting the UPS, it outputs normally, but it works in the battery mode and the buzzer beeps intermittently.	<ol style="list-style-type: none"> 1. Check if the contactors and wiring terminals in the input circuit are in good condition; 2. Check if the displayed input voltage amplitude or frequency of mains on the LCD is beyond the allowable range of UPS; 3. Check if the mains input breaker is disconnected, if yes, please close the breaker again.
After installing UPS, connecting with power will fuse the fuse or cause tripping operation.	The wiring of UPS input or output is short circuit.
After starting, the LCD display and output are normal. But once connecting with load, it will stop outputting immediately.	<ol style="list-style-type: none"> 1. UPS is overload seriously or the output circuit is short-circuit. Please reduce load to proper capacity or find the short-circuit reason. The common reason is that the output changeover socket short-circuit or the input short-circuit after UPS damage;

Fault phenomenon	Possible reason
	2. The load is not started according to "high power device → small power device". Restart the UPS, and after the UPS works steadily, start high power load first, and then start small power ones successively.
Buzzer long beeps, fault indicator lights on, UPS works in bypass mode and inverter failure.	<ol style="list-style-type: none"> 1. The output is overload. The load is too heavy and beyond the rated power of the UPS. Please reduce load or select a UPS with larger power capacity. If it is temporary bypass caused by impact of load start and recovers automatically, it still is normal; 2. UPS over-temperature protection. Check if the air inlet and air outlet of UPS is blocked or the working temperature of UPS is beyond the allowable range.
Usually, UPS works normally. When power failure, it doesn't transfer to battery mode or it transfers to battery mode and battery under-voltage protection soon.	<ol style="list-style-type: none"> 1. Battery aging, the battery capacity loss. Please replace battery; 2. Battery charger fault. At ordinary time, the battery cannot be charged; 3. Battery wire doesn't connect well or the terminals contact is bad.
When the load is PC, everything works normally. When power failure, UPS works normally, but the computer system halted.	The grounding connection is not so good. The floating voltage between the neutral wire and the grounding wire is too high.

Table5-2 Meaning of fault symbol and buzzer status

NO.	LCD fault symbol	Buzzer status	Meaning
1	EPO	Long beep	UPS has emergency protection (if equipped with EPO function), Bypass output and inverting output are all closed.
2	Phase Set	Long beep	UPS system mode system settings and the

NO.	LCD fault symbol	Buzzer status	Meaning
	Err.		actual wiring do not match the fault, please check the main power or bypass wiring, and make the actual system is consistent with the set mode system.
3	Maintenance	Long beep	UPS maintenance bypass protection, inverted output closed, please check back board maintenance bypass detection port is shorted.
4	Output fault	Long beep	The UPS output is faulty, detect the UPS output is short or over load.
5	Phase	Long beep	The UPS of the input and output mode in the parallel does not match the actual system.
6	Voltage	Long beep	The UPS of the output voltage in the parallel does not match the actual system.
7	Frequency	Long beep	The UPS of the frequency in the parallel does not match the actual system.
8	Bypass	Long beep	The UPS of the bypass voltage or frequency in the parallel does not match the actual system.
9	Mode	Long beep	The UPS parallel mode setting in the parallel system does not match the actual system.
10	Power	Long beep	The UPS of the output power setting in the parallel does not match the actual system.
11	Number	Long beep	The UPS of the battery number setting in the parallel does not match the actual system.
12	PRA	Long beep	The UPS of parameters setting in the parallel does not match the actual system.
13	Short turn to bypass	Long beep	The UPS of short turn to bypass setting in the parallel does not match the actual system.
14	Double Err.	Long beep	Fall-off fault at both ends of the parallel wire.

NO.	LCD fault symbol	Buzzer status	Meaning
15	Single Err.	Slow beep	Fall-off fault at one ends of the parallel wire.
16	PWR	Long beep	UPS internal working power failure, if it cannot be automatically recovered, please report repair promptly.
17	Fan fault	Urgent beep (alarm once about every 0.2s)	Fan fault warning prompt, please check the fan for damage or blocking.
18	CAN fault	Slow beep(alarm once about every 2.0s)	The CAN communication of parallel system abnormal, please check if the parallel wire is damaged or there is only one UPS in parallel system works.
19	SCI fault	Long beep	UPS internal communication abnormal, if the continuous alarm cannot be restored, please report repair promptly.
20	No Redund	Slow beep (alarm once about every 2.0s)	The total output load of the UPS parallel system exceeds the full load of the single machine, check that the output load exceeds the requirements for redundant backups.
21	Grid Err.	Long beep	The mains power input phase sequence is abnormal, please check the main power input wiring.
		3 continuous alarms at 10s intervals	The main power input occur lack N fault, power down failure, overvoltage protection, under voltage protection, over-frequency fault, under-frequency fault, please check whether the main power input status is normal.
22	BYP Err.	Slow beep (alarm once about every 2.0s)	At mains status, the bypass voltage abnormal, frequency abnormal, phase sequence abnormal, or mode setting mismatches the wiring. Please check if the bypass breaker is closed, if the

NO.	LCD fault symbol	Buzzer status	Meaning
			bypass phase sequence is normal, if the wiring way of bypass matches the system mode setting.
23	BAT Err.	Slow beep(alarm once about every 2.0s)	Battery has been pressure protection, charging fuse failure, over-pressure alarm fault, please check the battery status is normal.
		Urgent beep(alarm once about every 0.2s)	Battery wiring fault, charging short, under-voltage protection, under-voltage warning problem, please check the battery wiring and the current state is normal.
		No buzzer warning	The battery charging temperature is too high.
24	PFC Err.	Long beep	UPS rectifier fault.
25	INV Err.	Long beep	UPS inverter failure.

**NOTE**

The buzzer alarm in the table above describes the phenomenon of UPS boot state and no beep ban when the buzzer is not set, the shutdown state or some abnormal phenomena when setting the buzzer ban will prompt the information in the LCD, but the buzzer alarm will not be issued.

6 Package, Transportation and Storage

6.1 Package

During packing, please pay attention to the place direction requirements. At the side of the package, there is afraid of wet, handle with care, upward, stack layer limit, etc. alarm marks. And also, the device model is printed on the package. At front of the package, the device name is printed.

6.2 Transportation

During transporting, pay attention to the warning marks and avoid severe impact on the package. Place the device according to the marked direction, which is to avoid damage the component. Any inflammable, explosive, corrosive object is not allowed to shipping with the device. While midway transportation, do not put the device in the open air. The device cannot suffer any rain, snow or liquid material or mechanical damage.

6.3 Storage

During storing, place the UPS according to the marked direction. The package box should be far away from ground for 200mm, and keep at least 500mm from wall, eat source, cold source, window or air inlet.

Storage temperature: 0~40°C, relative humidity is 20% ~ 80%.In the warehouse, any inflammable, explosive, corrosive object or harmful gas is not allowed, and also, strong mechanical shake, impact or magnetic field is forbidden. The storage period of these requirements, generally, is 6 months. If the UPS is stored more than 6 months, it is necessary to check again. If the UPS is stored for a long time, please charge the battery every 3 months.

A Technical Specifications

Model		10kVA	15kVA	20kVA	30kVA	40kVA
Index						
Input	Input mode	3W+ N+PE(can be set as 1W+ N+PE)			3W+ N+PE	
	Voltage range (Vac)	When the input voltage in the range of 176~280, the UPS can bear load of 100% rated power; When the input voltage in the range of 80-176, the output of the UPS needs to decrease rated power linearly to use				
	Frequency range (Hz)	40~70				
	Bypass synchronism track range(Hz)	50/60±10%(50/60 self-adaption)				
	Bypass input voltage range (Vac)	208/220/230/240±20% (phase voltage) (default is 220)				
	Input power factor	≥0.99				
	Input THDI	Resistive full load:≤3%; non-linear full load: ≤5%				

Model		10kVA	15kVA	20kVA	30kVA	40kVA
Index						
	Battery voltage (Vdc)	±144~±240 (can be selected from ±12 cells ~±20 cells, default is ±16 cells, when the battery voltage is set from ±12 cells ~±15 cells, the output of the UPS decreases to 75% rated) (single battery voltage is 12Vdc)				
	Charge current (A)	1~10 settable (default is 4A)			1~20 settable (default is 15A)	
Output	Output mode	3W+N+PE(can be set to 1W+N+PE)				
	Capacity (kVA/kW)	10/9	15/13.5	20/18	30/27	40/36
	Voltage (Vac)	L-N: 220/230/240(default is 220) L-L: 380/400/415 (default is 380)				
	Frequency (Hz)	When mains normal, it tracks the bypass input frequency; When mains abnormal, it tracks the frequency of 50±0.1 or 60±0.1 (default is 50)				
	Wave form	Sine-wave				
	Voltage distortion	Resistive full load: ≤1%; non-linear full load:≤4%				
	Power factor	0.9(when PF set to 1.0, the UPS can output long time)				
	Transfer time of bypass and inverter (ms)	Synchronization: < 1ms; asynchronization: < 10ms				
	System efficiency	Up to 96%				
	Overload capacity	Inverter: <115%: continue 115%~130%: 15min				

Model		10kVA		15kVA		20kVA		30kVA		40kVA	
		Index									
		130%~150%: 1min > 150%: 200ms Bypass: <130%: continue 130%~155%: 1min > 155%: 200ms									
Others	DC startup function	Equipped									
	Panel display	LCD shows the running status of the UPS									
	Communication port	RS485									
	Alarm function	Alarm for battery low-voltage, mains abnormal, UPS fault, output overload, etc.									
	Protection function	Protection for battery under-voltage, overload, short-circuit, over-temperature, input over-voltage, communication abnormal, etc.									
	Noise (dB)	<55 (normal temperature)									
	Work temperature (°C)	-5 ~ 40									
	Relative humidity	0 ~ 95%, non-condensation									
	Size (W×D×H) (mm ³)	438×500×130					438×680×130				
	Weight (kg)	17.5		19		20		34			

- Specifications are subject to change without prior notice.

